

<b>RANGE :</b> BALISE	<b>REF :</b>	<b>MATERIAL/FINISHING :</b>
<b>PART :</b> BALISE 100-350 CH / BALISE 100-350 MESH CH		
<b>REV N° :</b> 1		

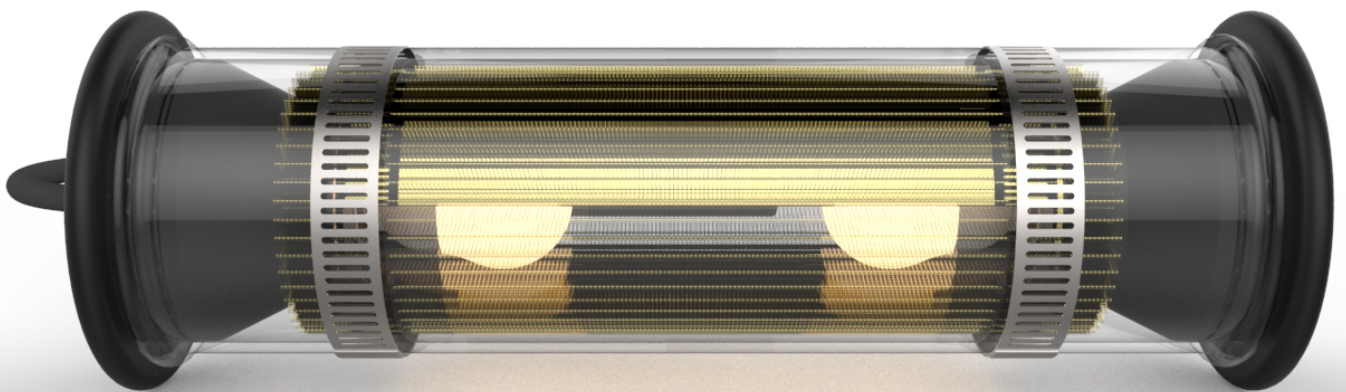

<b>RANGE</b> : BALISE	<b>REF</b> :	<b>MATERIAL/FINISHING</b> :
<b>PART</b> : BALISE 100-350 BR / BALISE 100-350 MESH BR		
<b>REV N°</b> : 1		

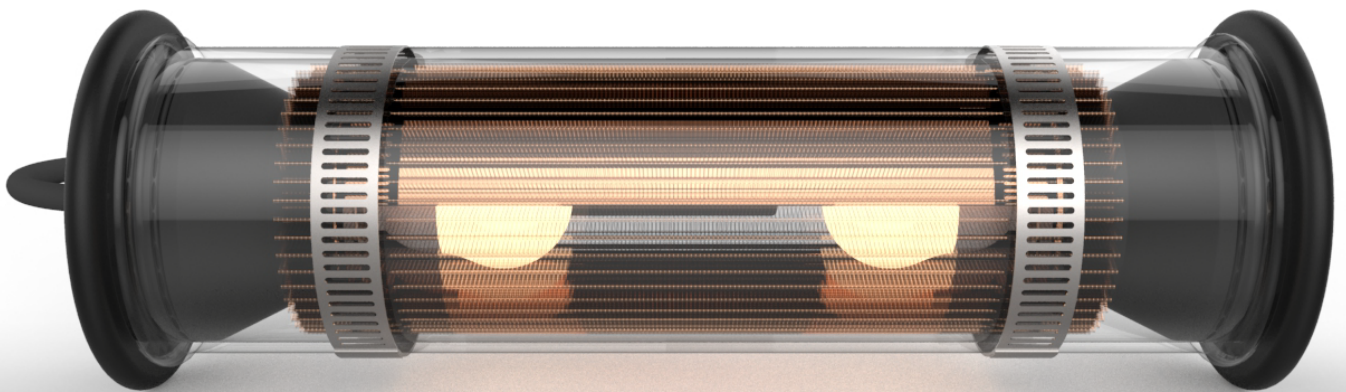
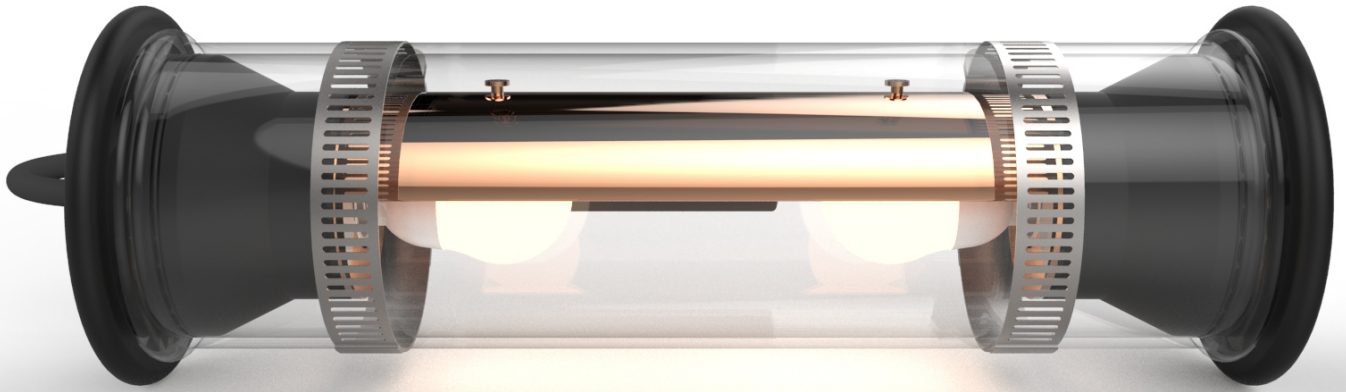

<b>RANGE</b> : BALISE	<b>REF</b> :	<b>MATERIAL/FINISHING</b> :
<b>PART</b> : BALISE 100-350 COP / BALISE 100-350 MESH COP		
<b>REV N°</b> : 1		

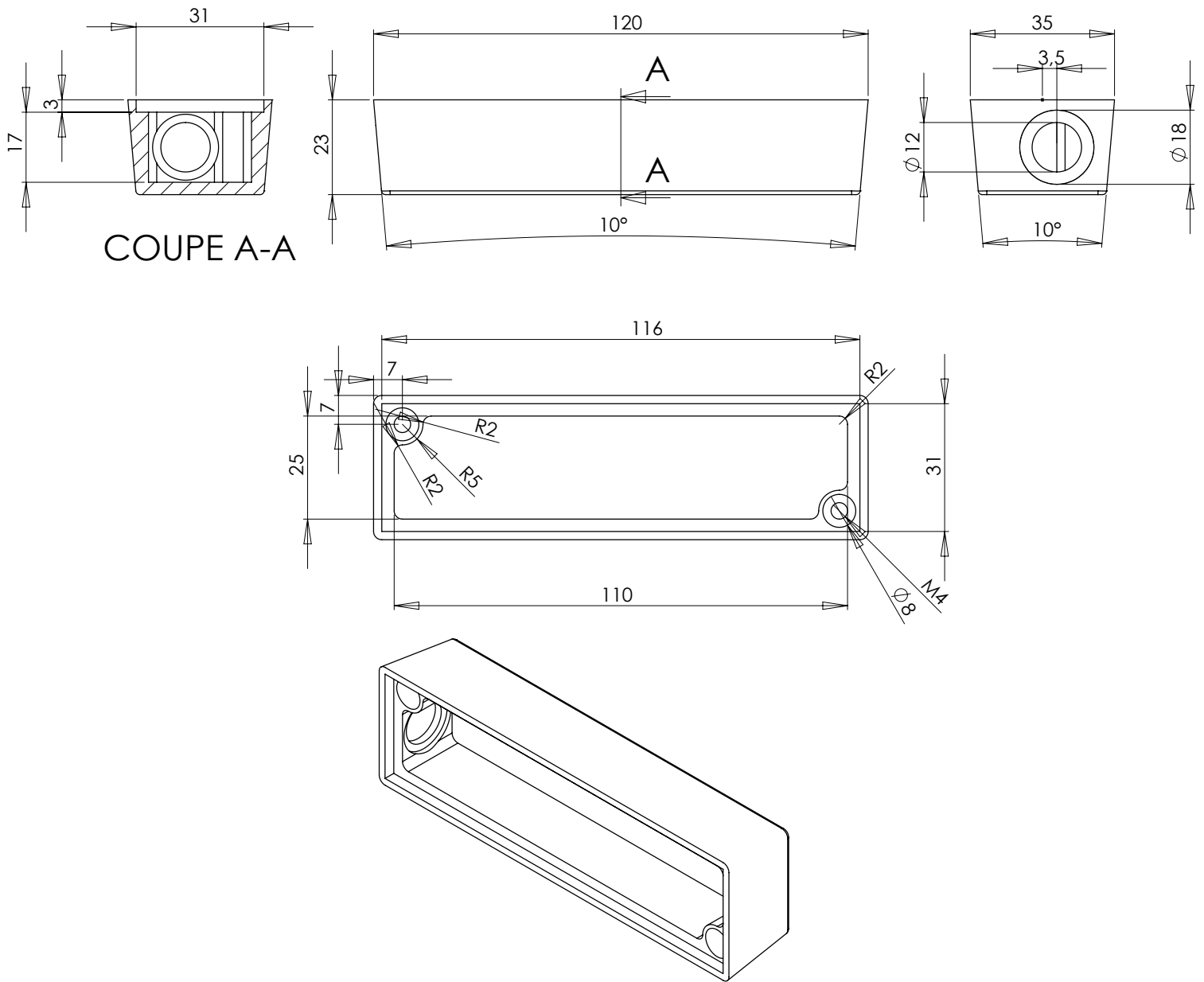

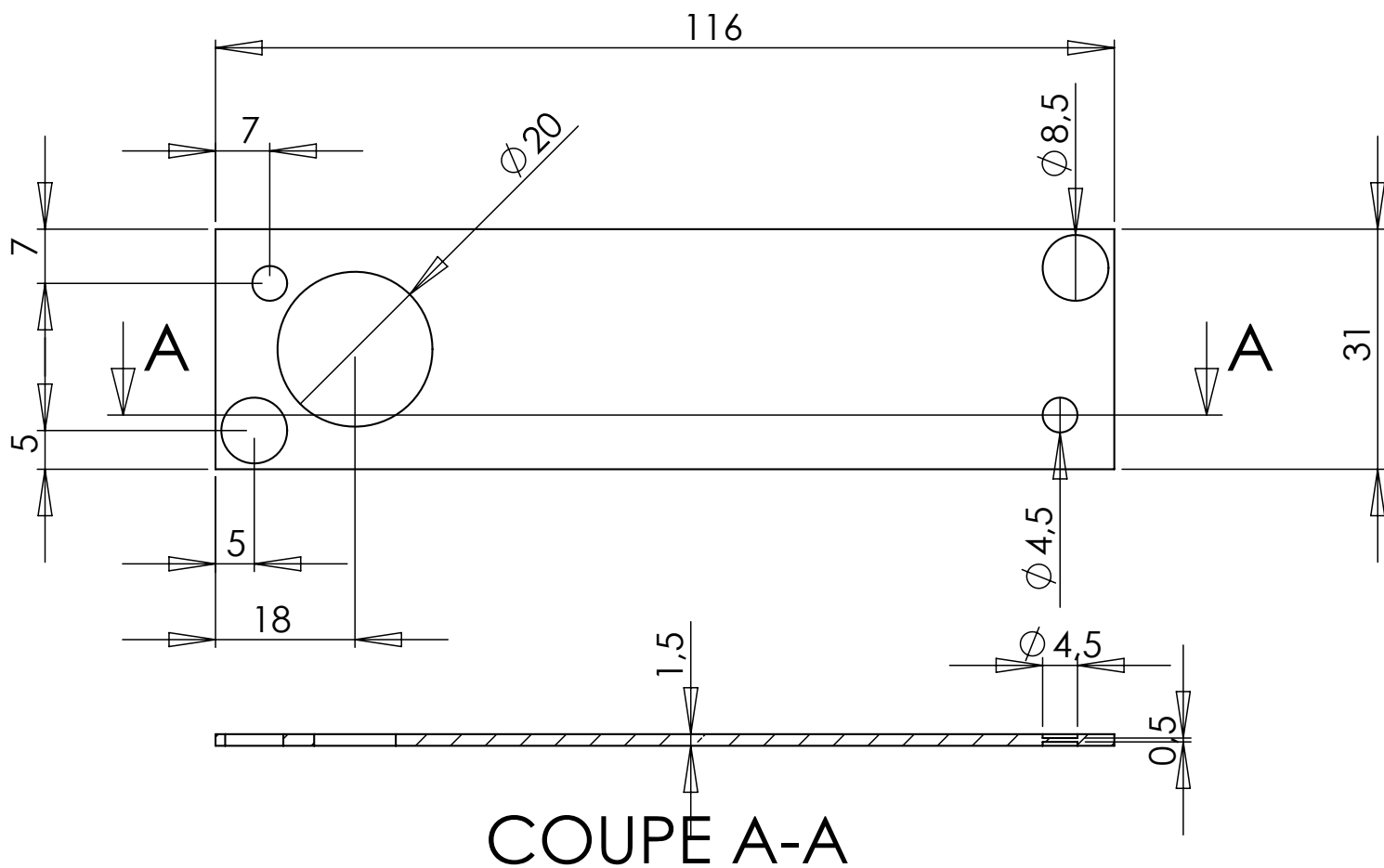

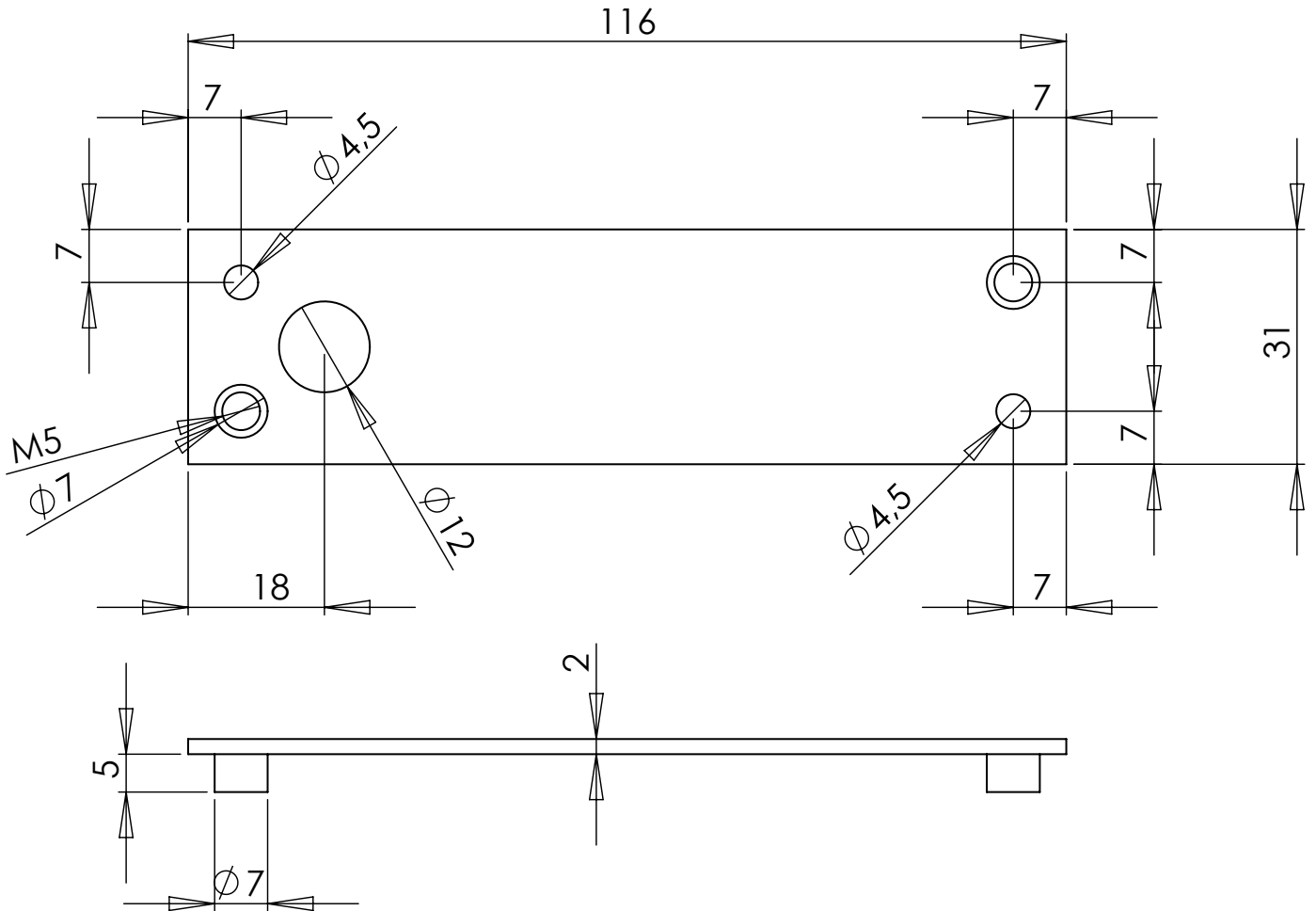

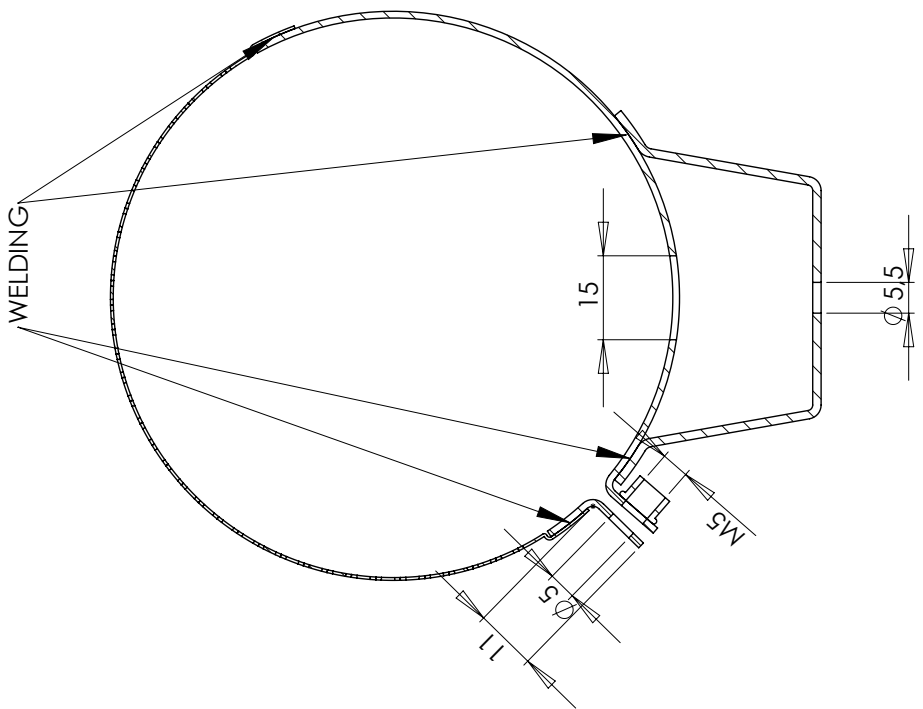
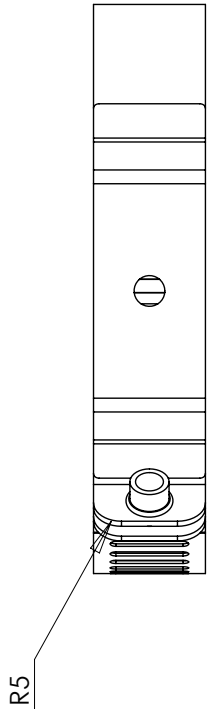
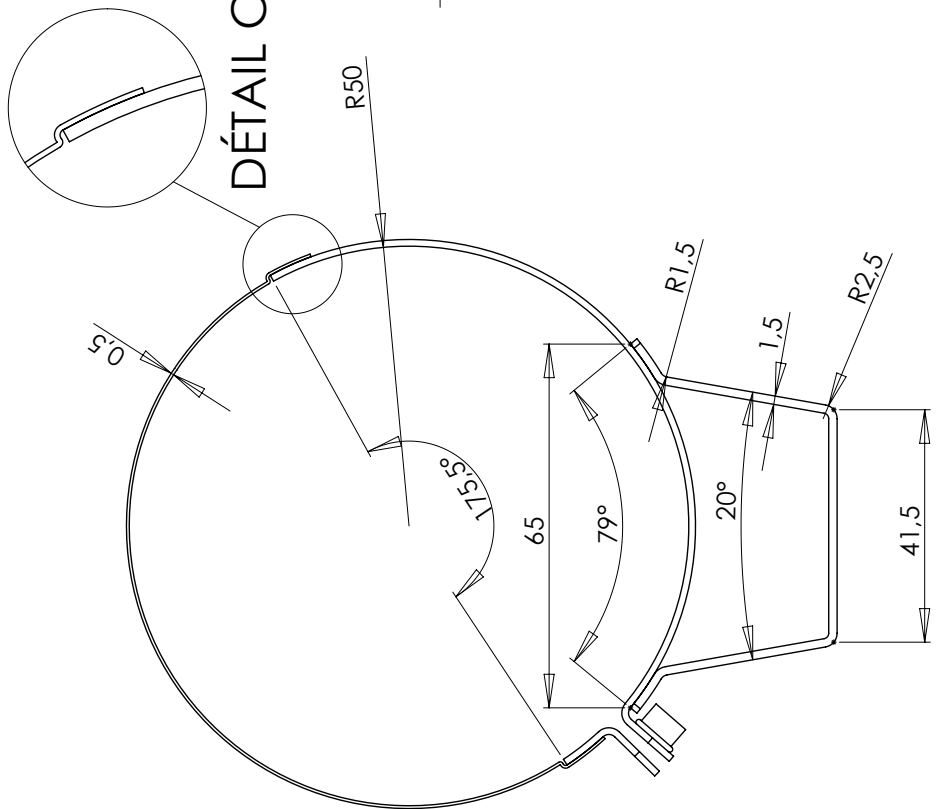
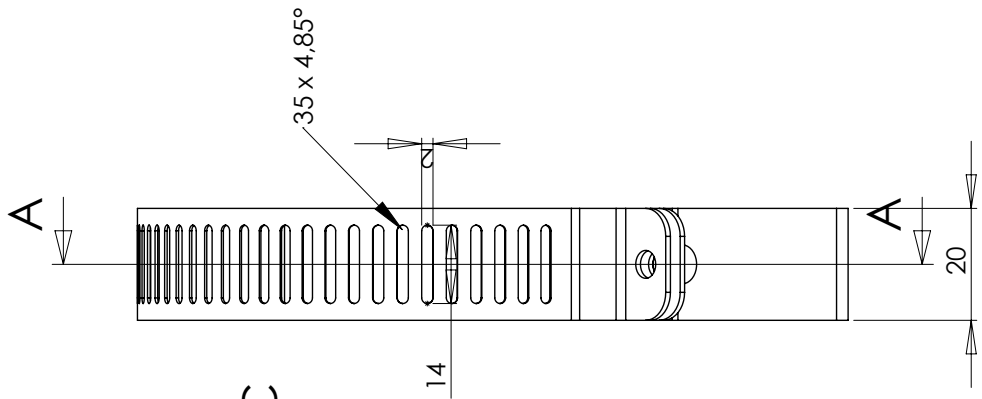

COUPE A-A

RANGE : BALISE	REF : 100	MATERIAL/FINISHING : STAINLESS STEEL 316L/ RAW FINISHING
PART : NECLACE		
REV N° : 1		

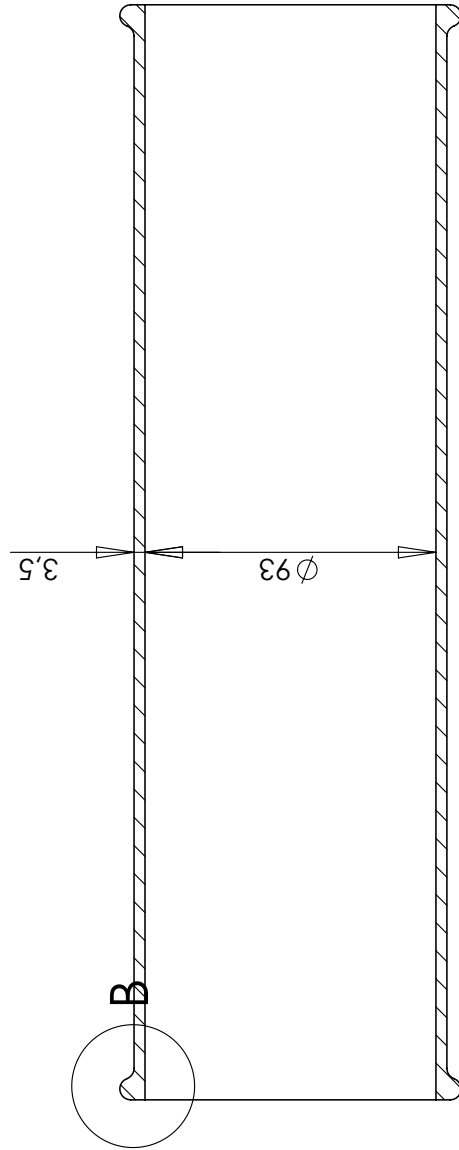
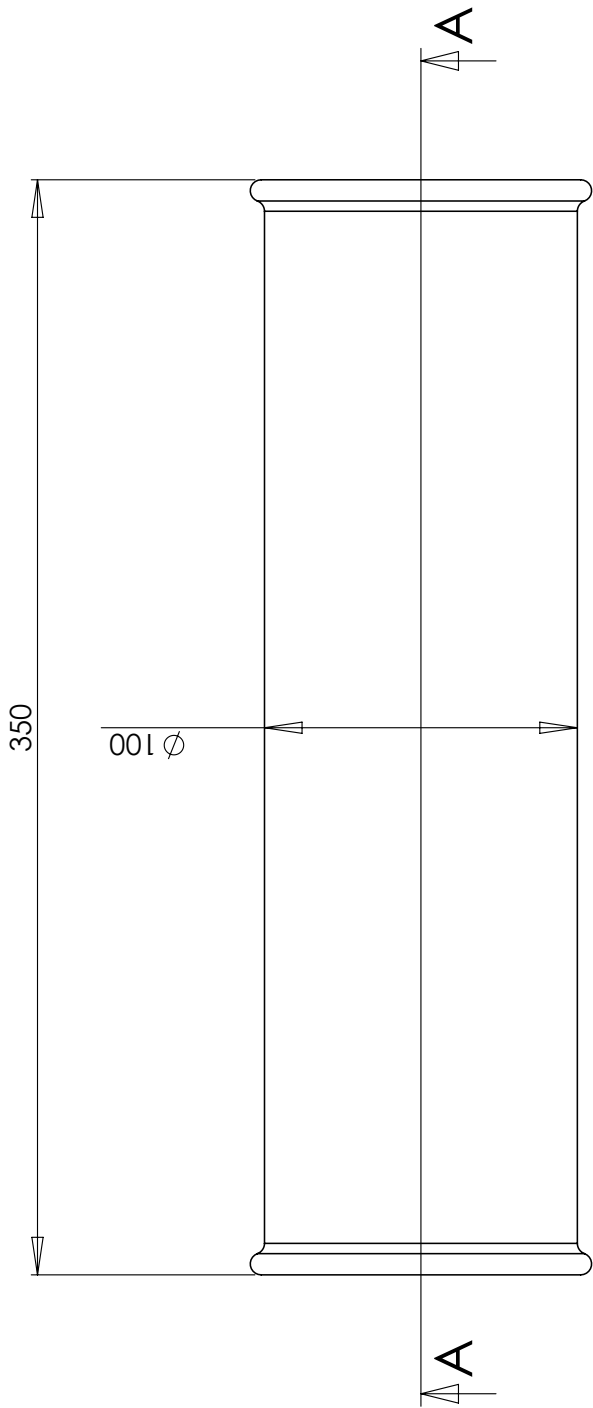

COUPE A-A

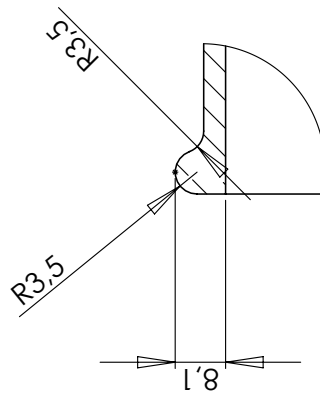
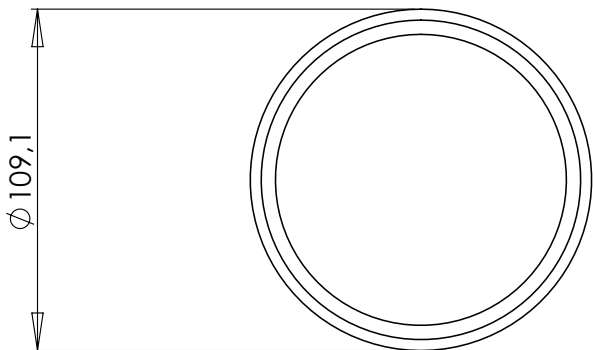

DÉTAIL B

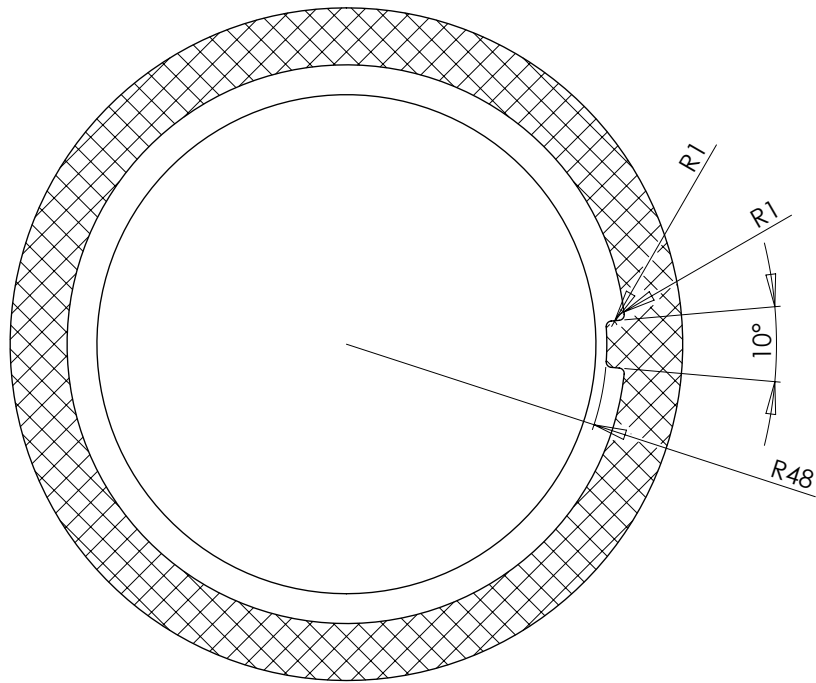

COUPE B-B

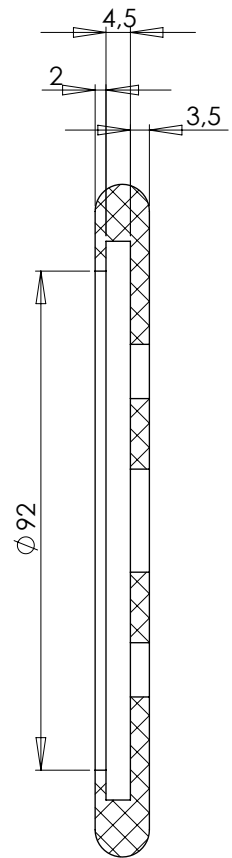
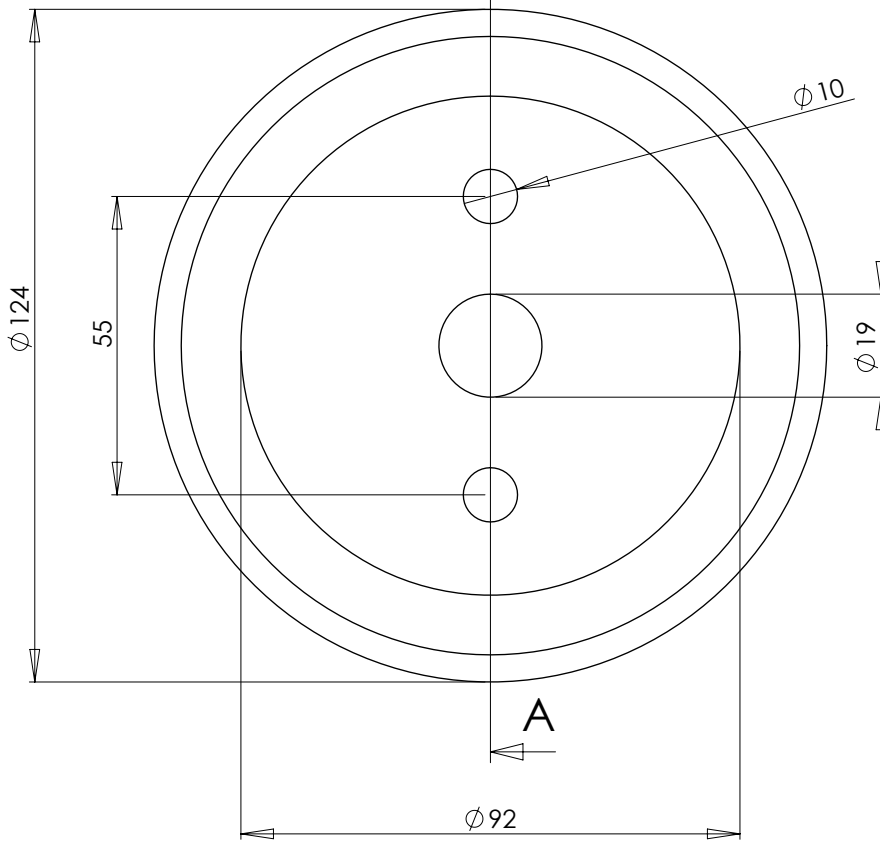
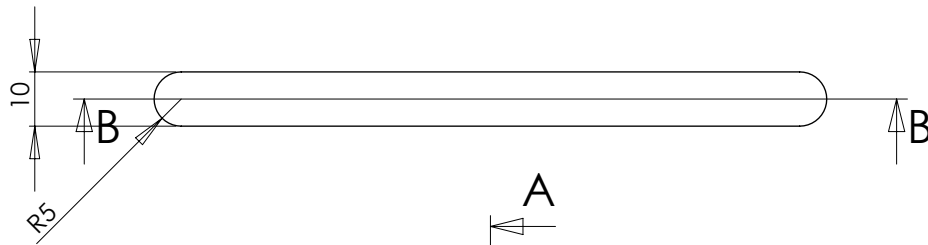

COUPE A-A

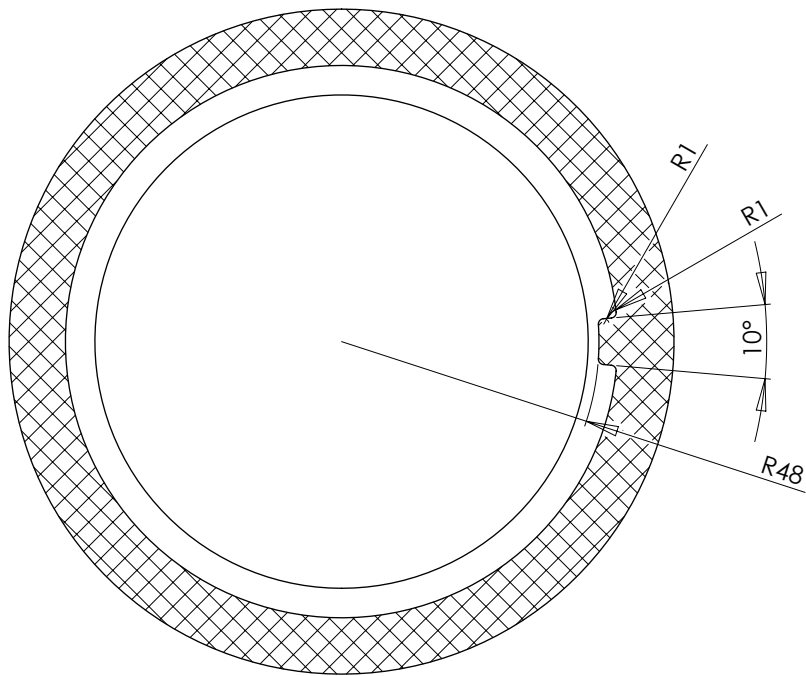

COUPE B-B

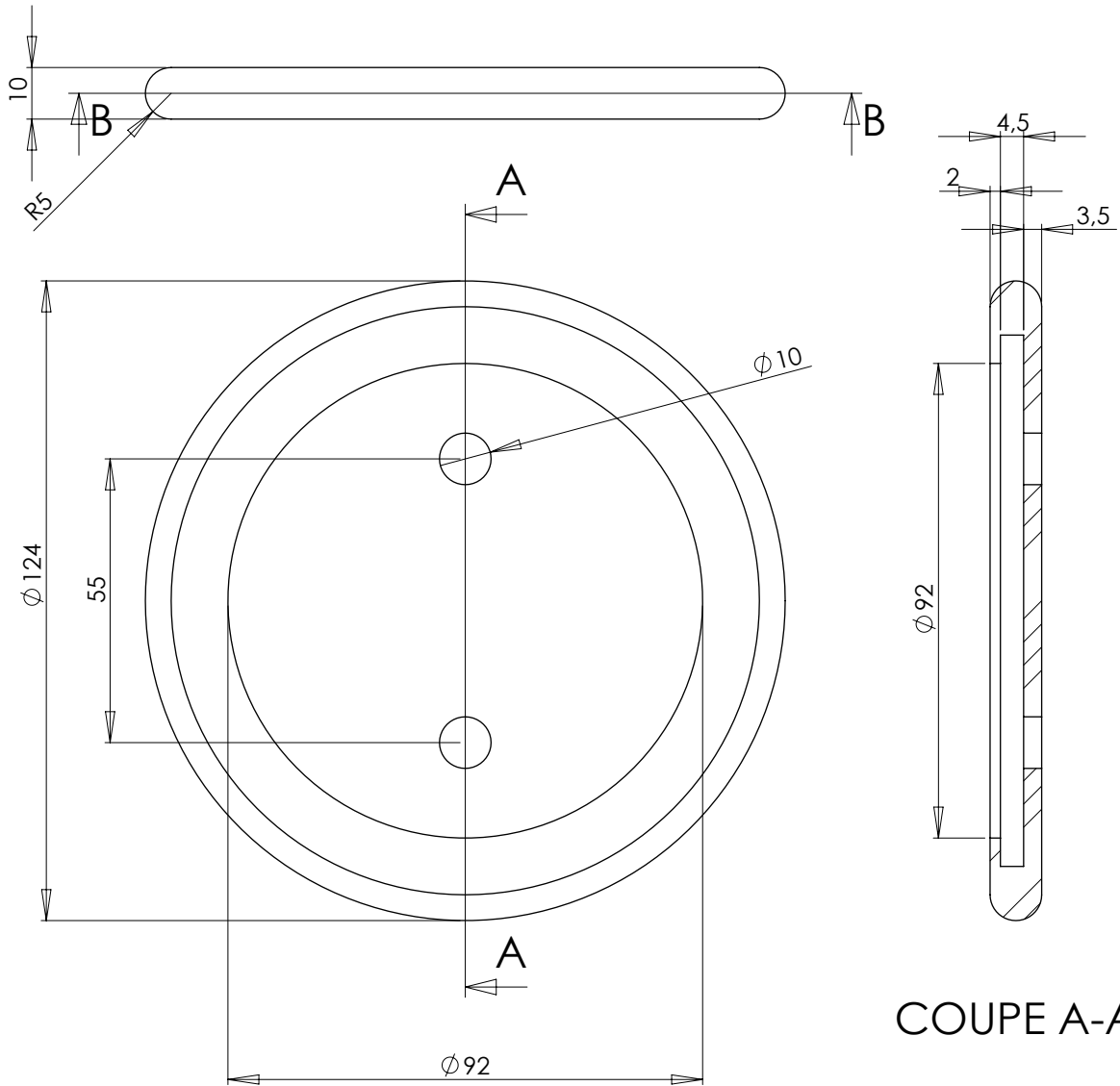

COUPE A-A

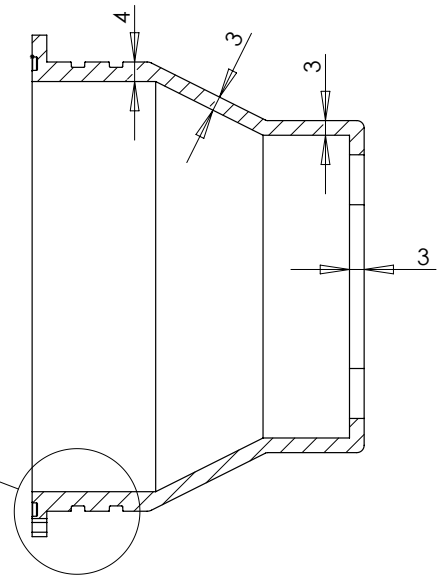
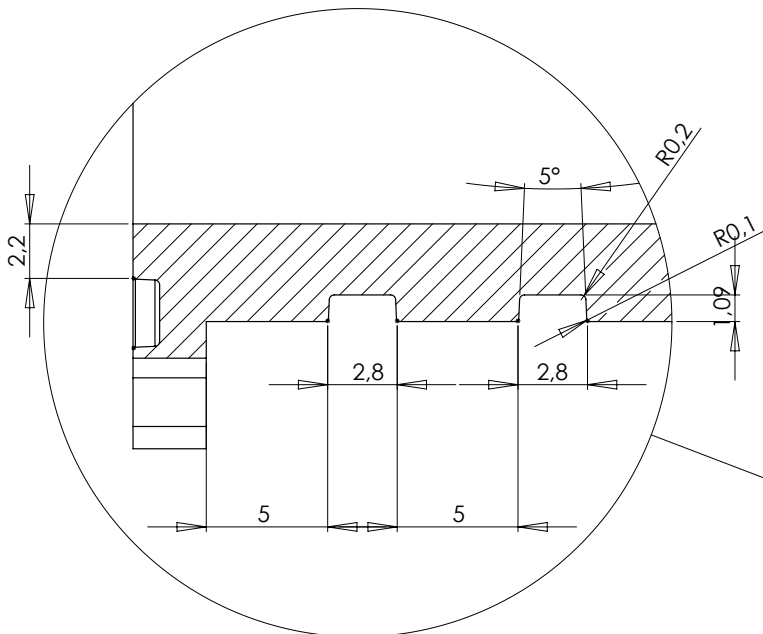
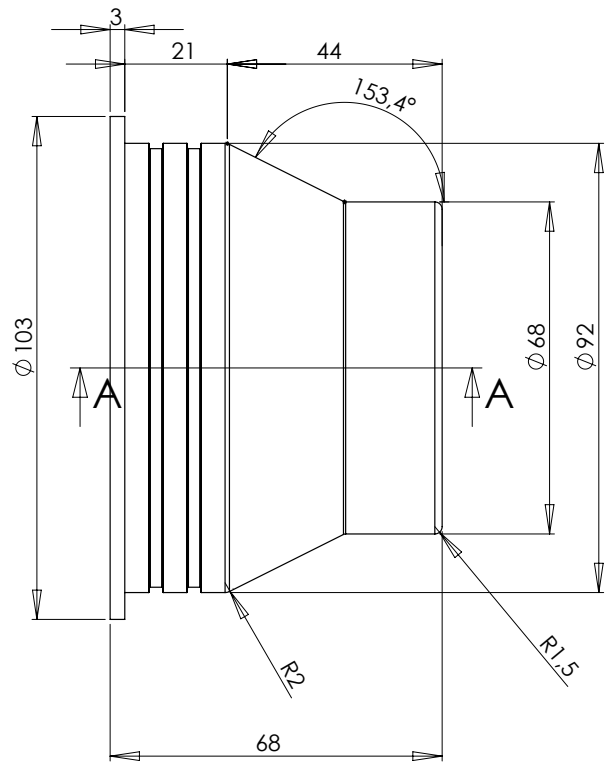
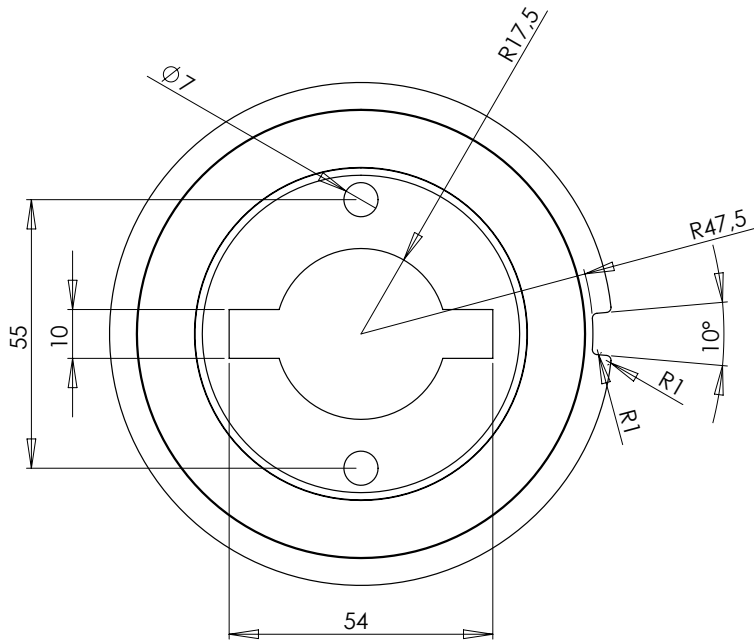

DÉTAIL B

COUPE A-A

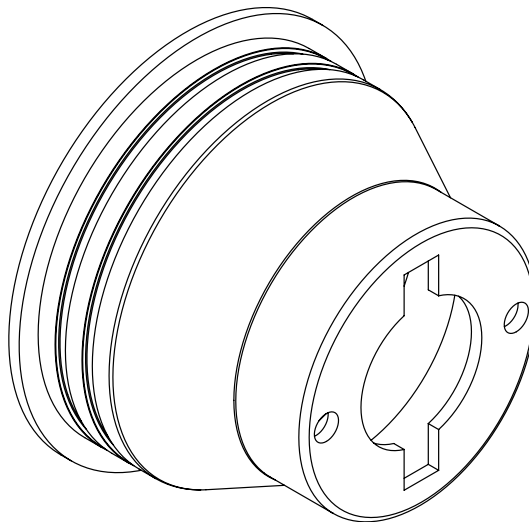

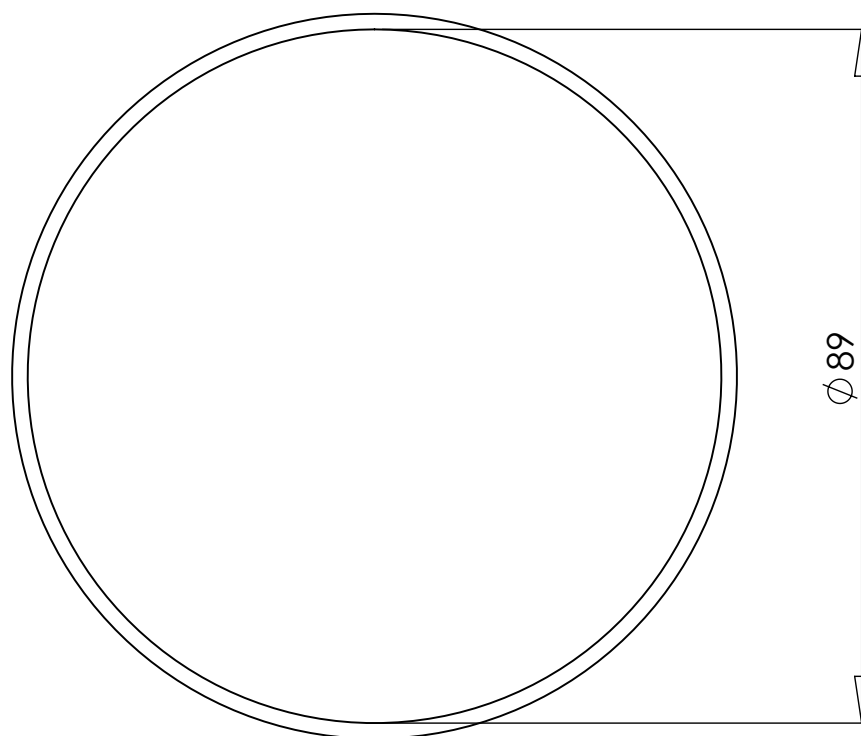
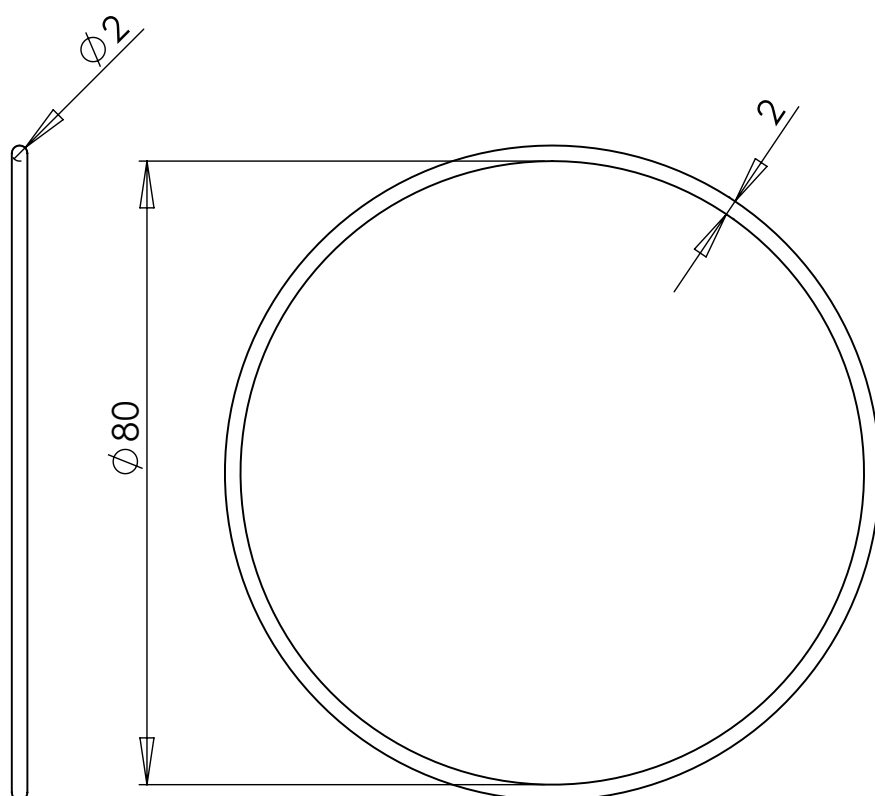

SEAL IN POSITION

RANGE : BALISE	REF : 100	MATERIAL/FINISHING : BLACK SILICONE
PART : TOTIC SEAL		
REV N° : 1		

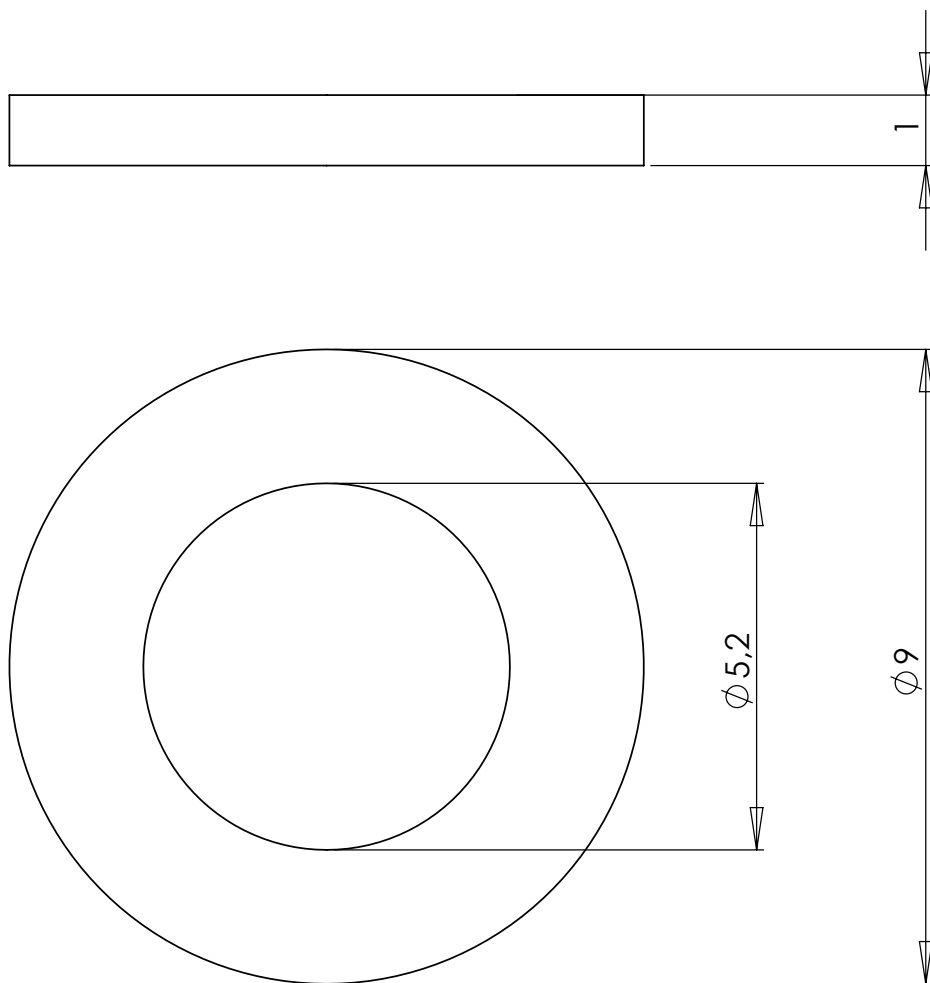

RANGE : BALISE	REF :	MATERIAL/FINISHING : BLACK NYLON
PART : M5 WASHER		
REV N° : 1		

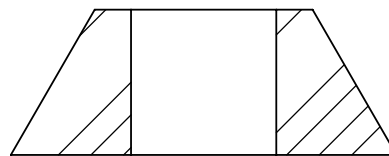
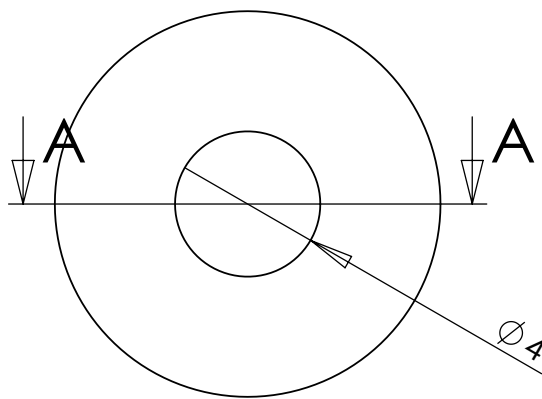
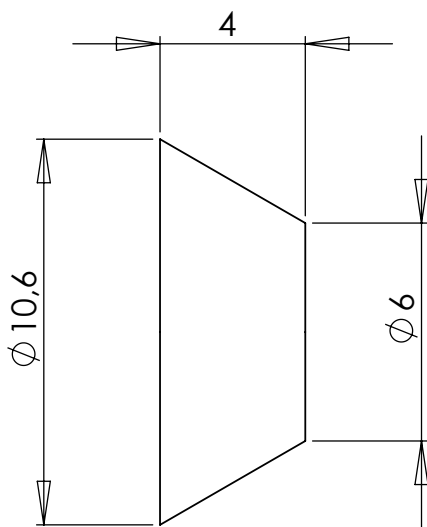

COUPE A-A

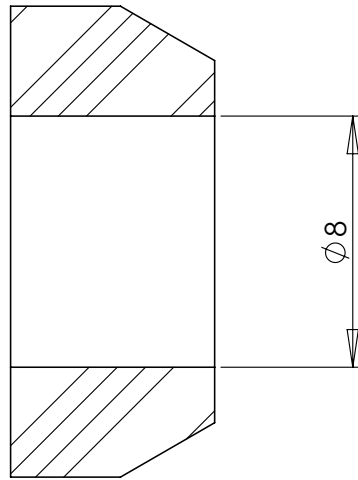
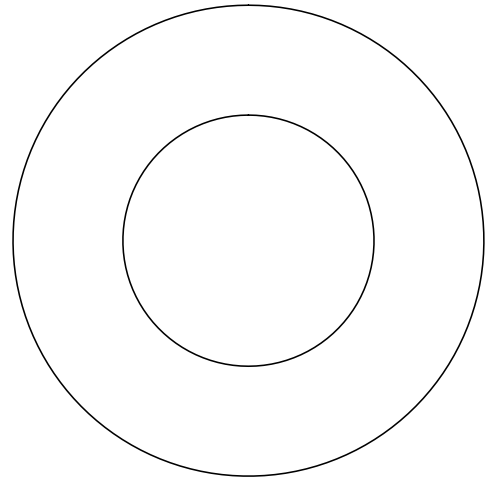
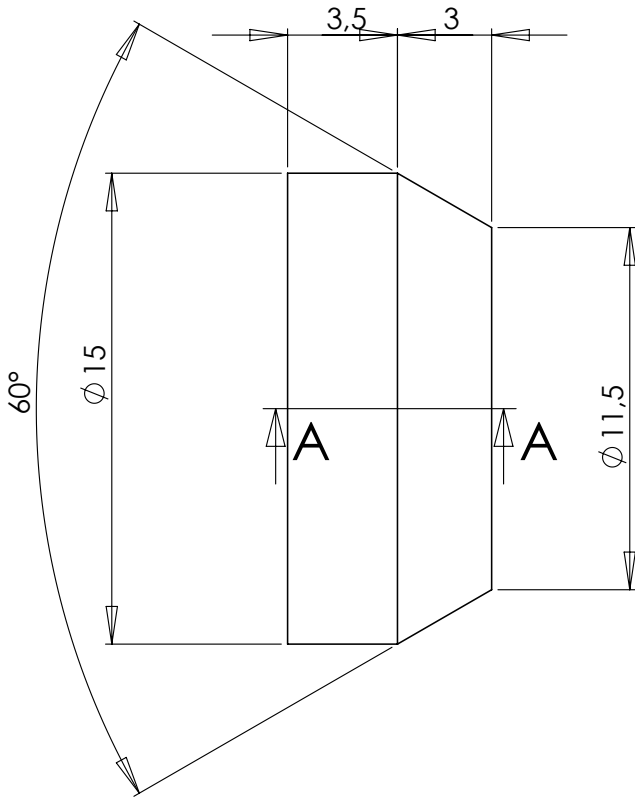

COUPE A-A

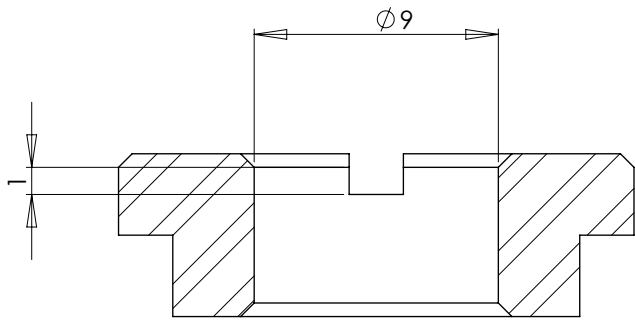

COUPE A-A

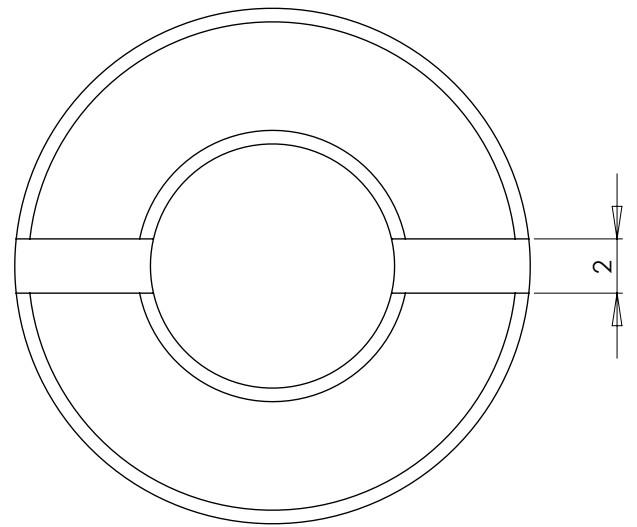
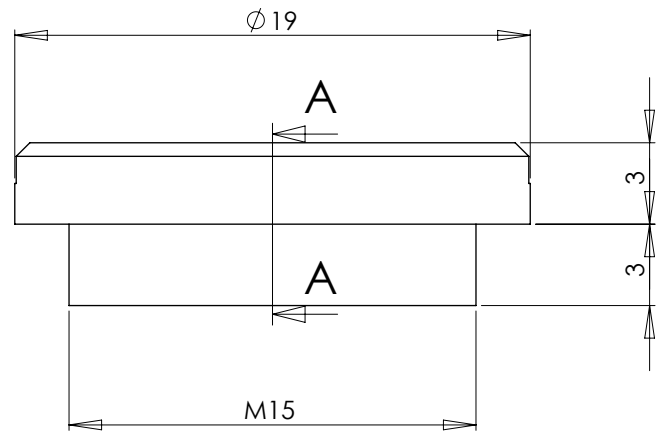

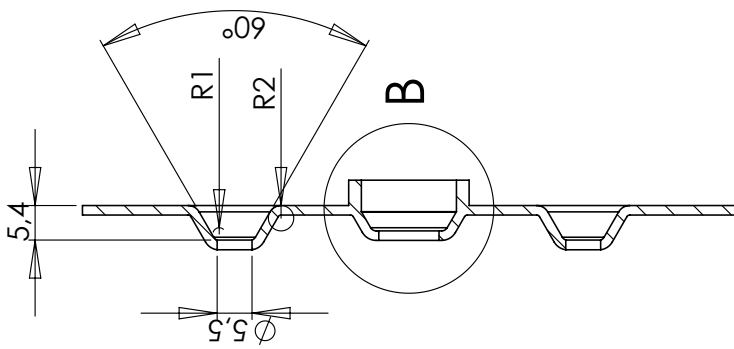
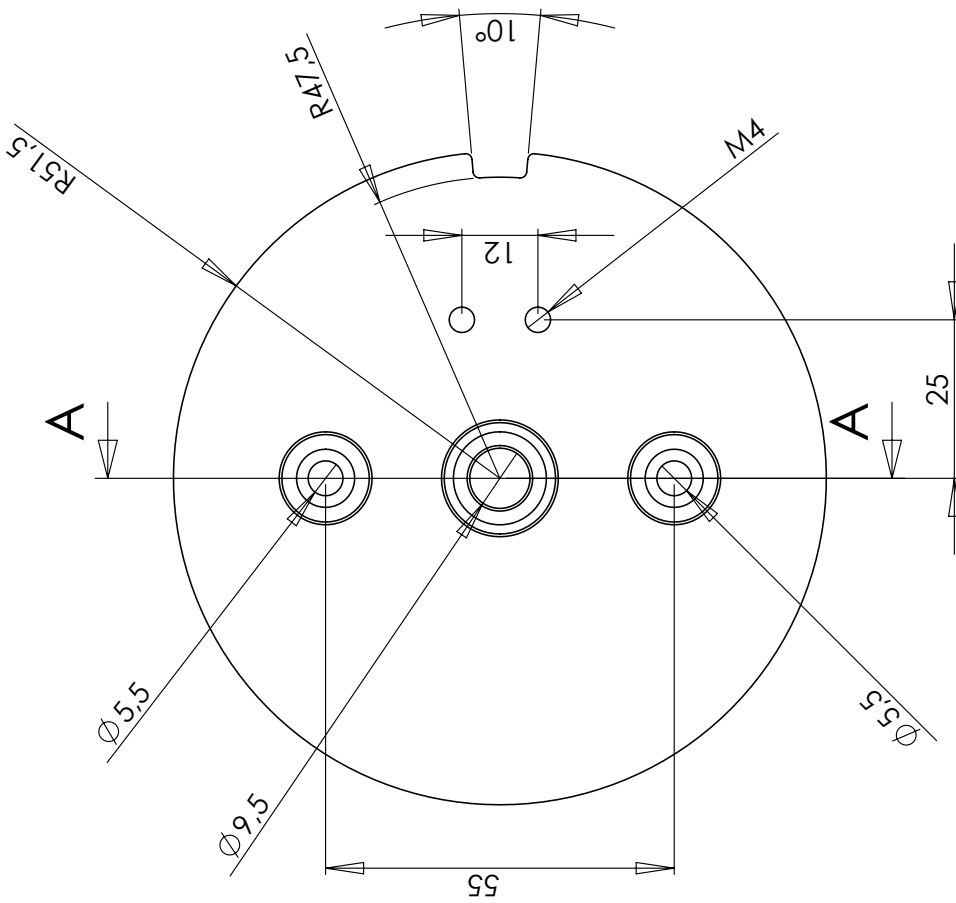
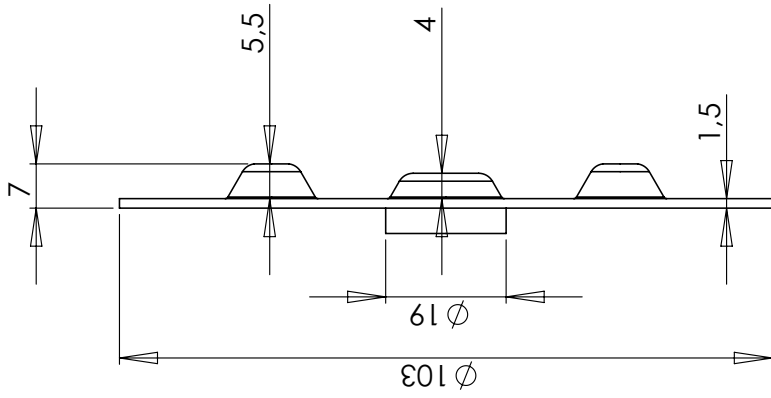

COUPE A-A

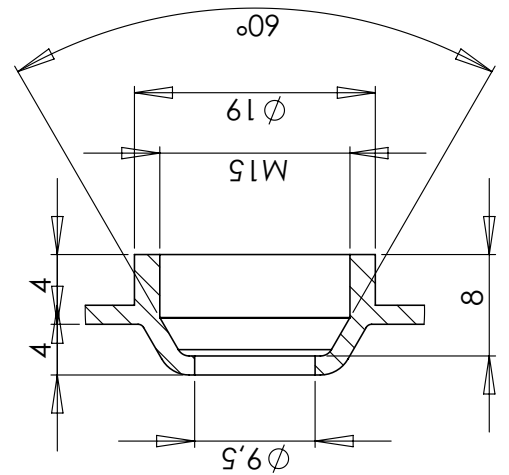

DÉTAIL B

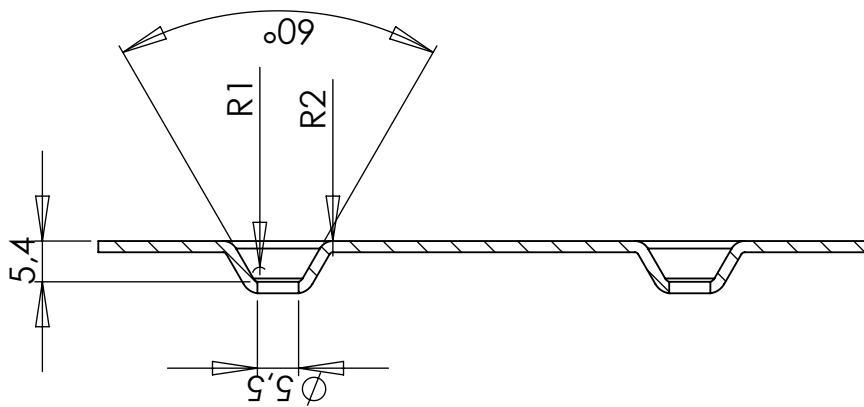
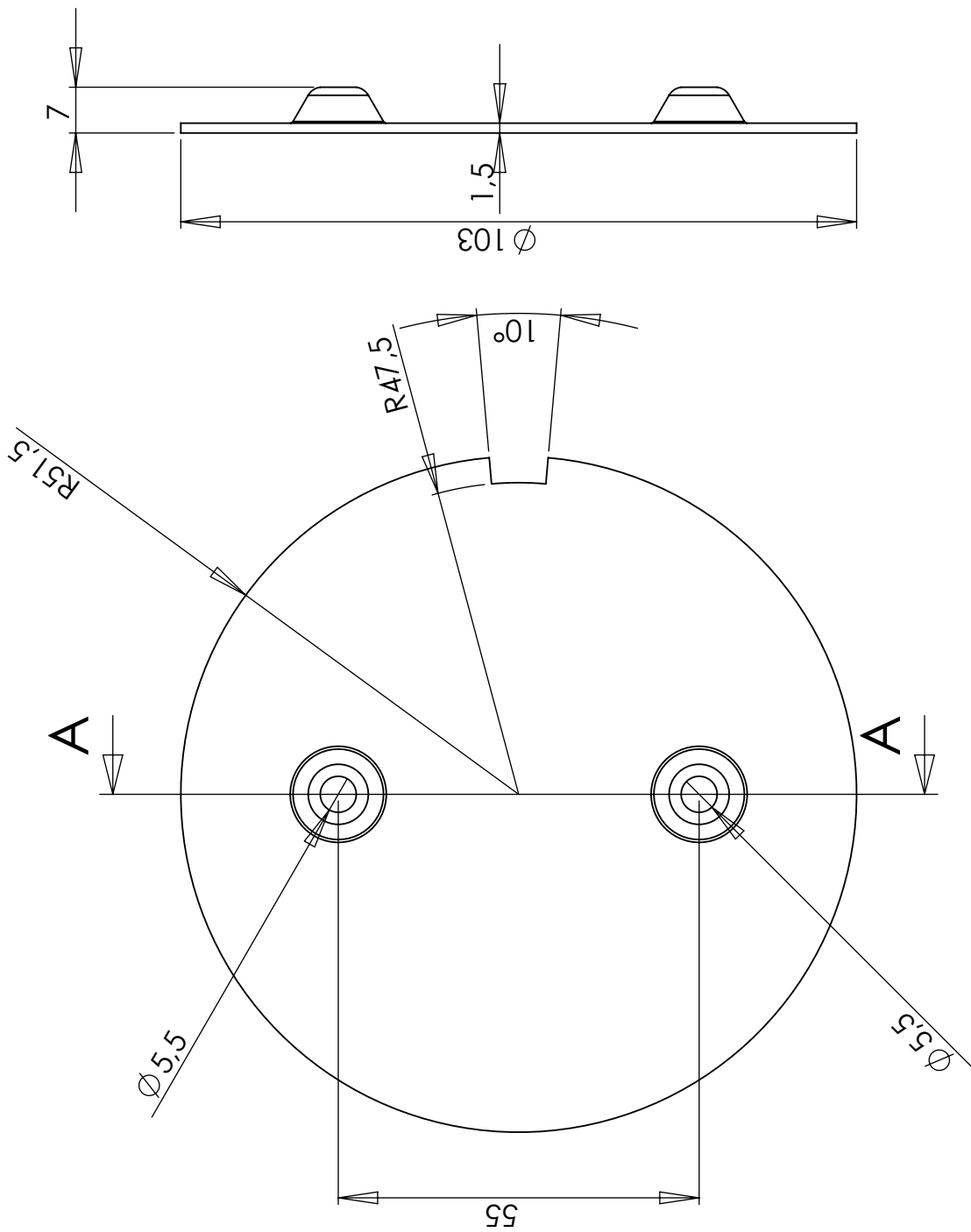

COUPE A-A

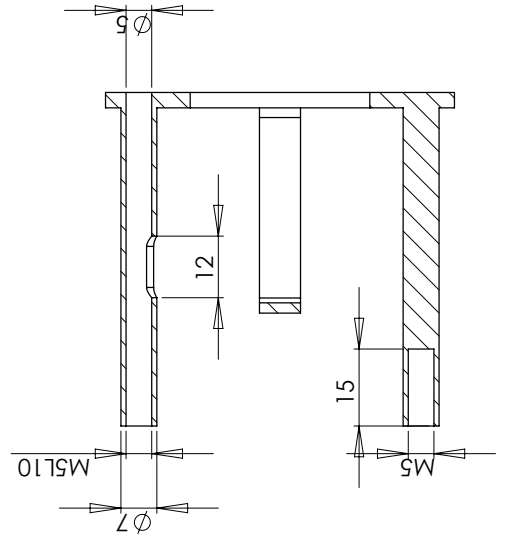
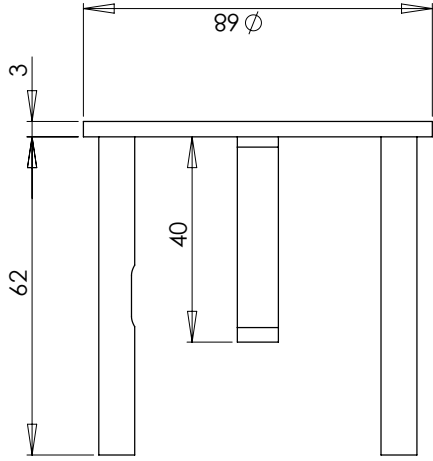
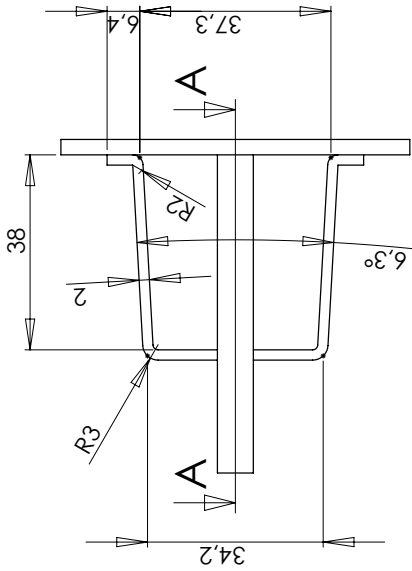
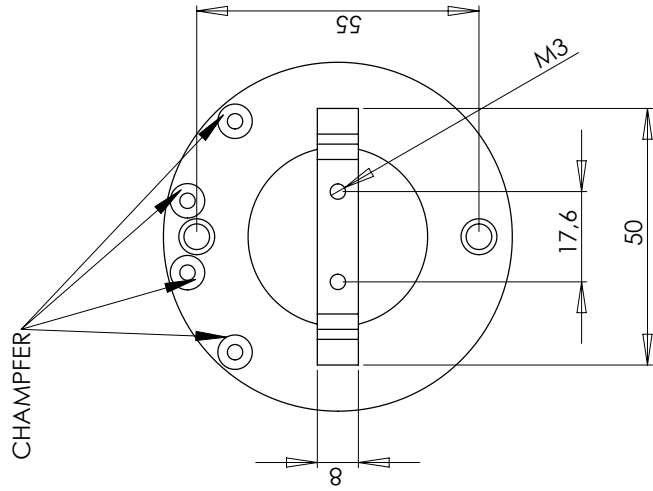

COUPE A-A

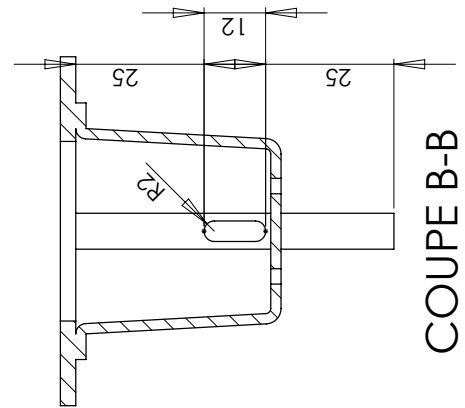
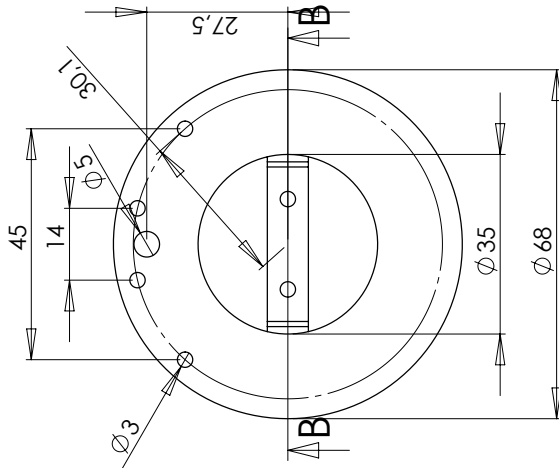

COUPE B-B

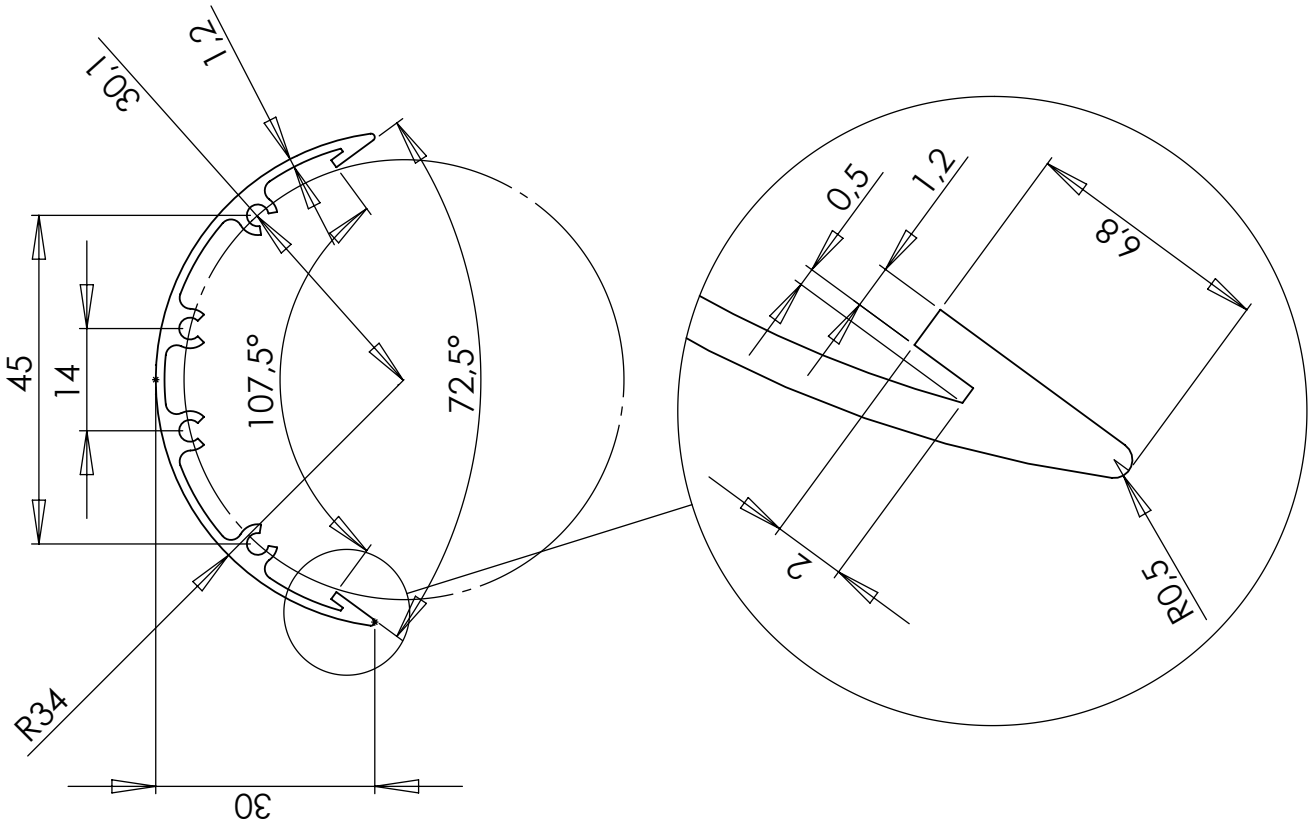
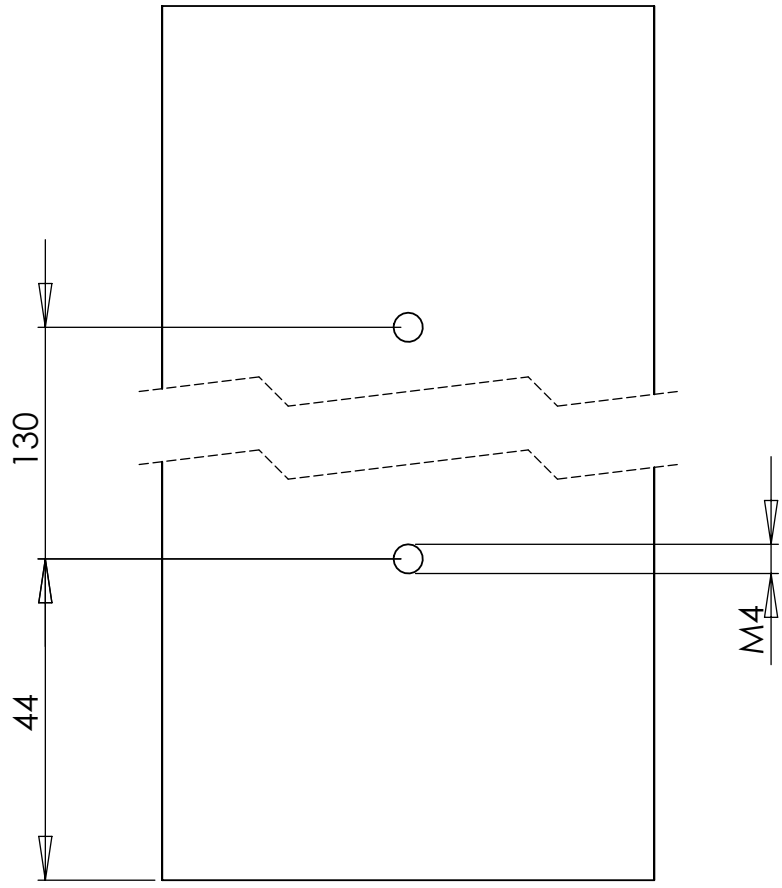
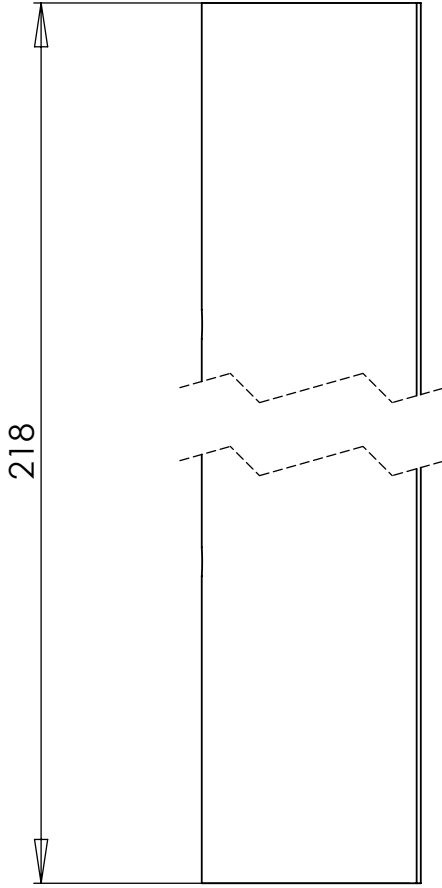

DÉTAIL A

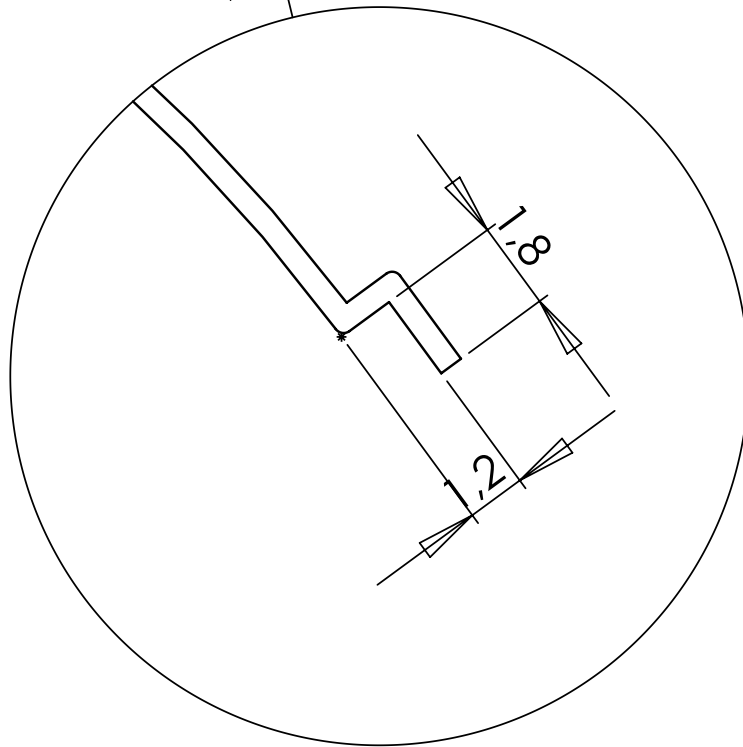
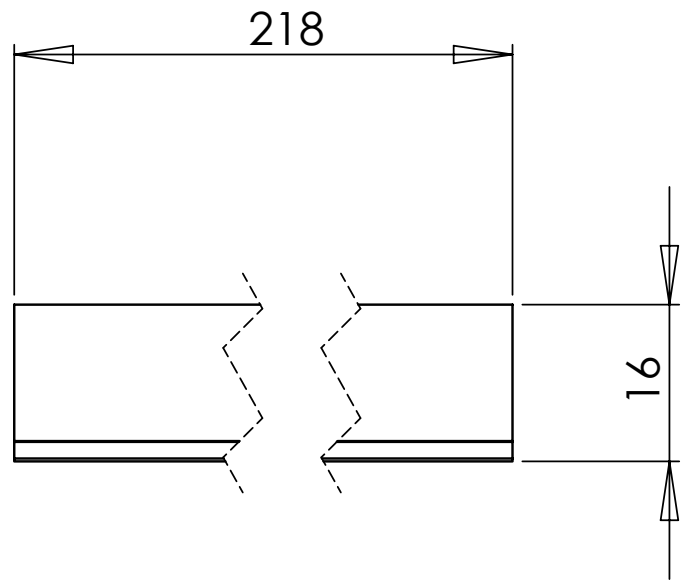
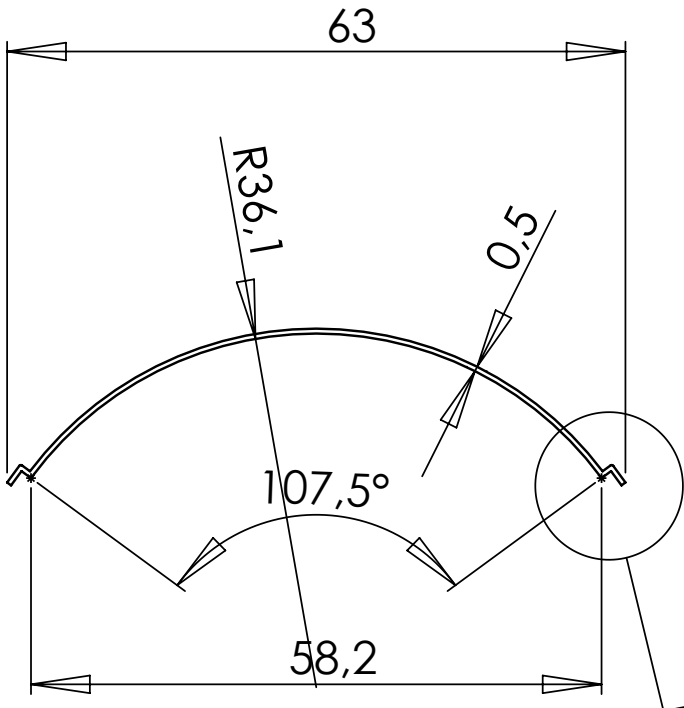

DÉTAIL A

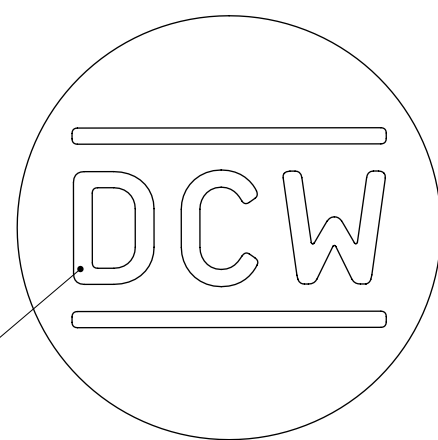
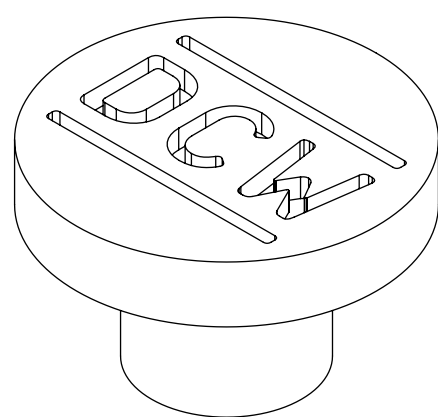
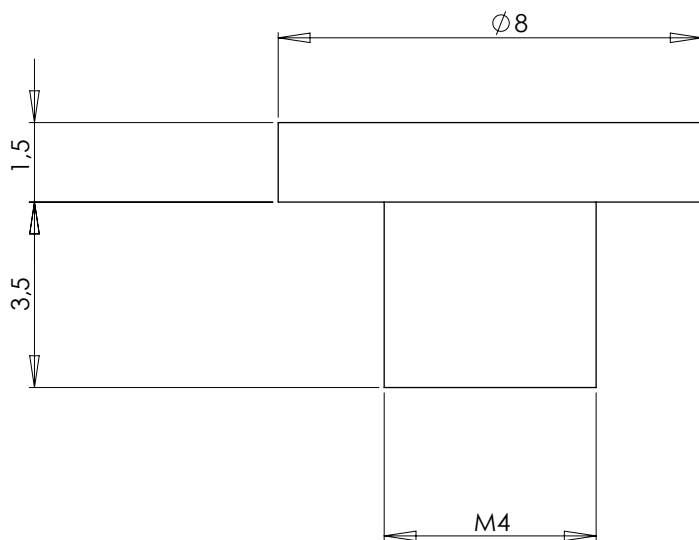

Engraved DCW logo



<b>RANGE</b> : BALISE	<b>REF</b> :	<b>MATERIAL/FINISHING</b> : STEEL CAST / SATIN CHROME; COPPERE- D; BRASSED
<b>PART</b> : TITON		
<b>REV N°</b> : 1		

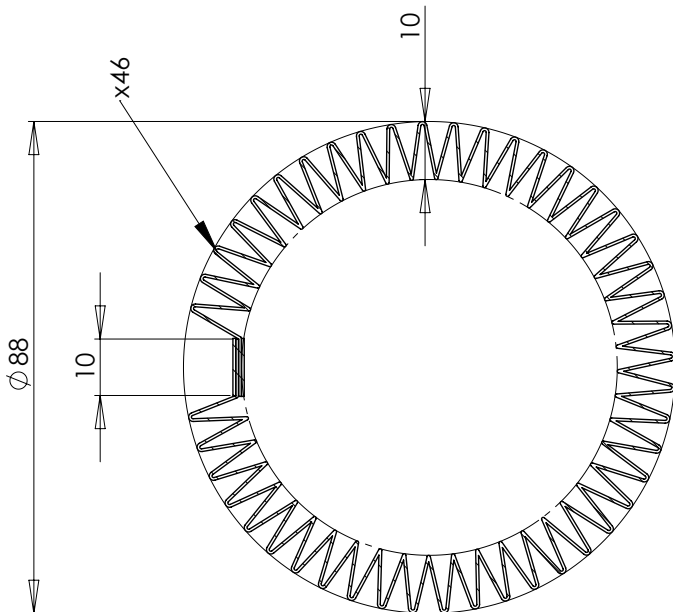
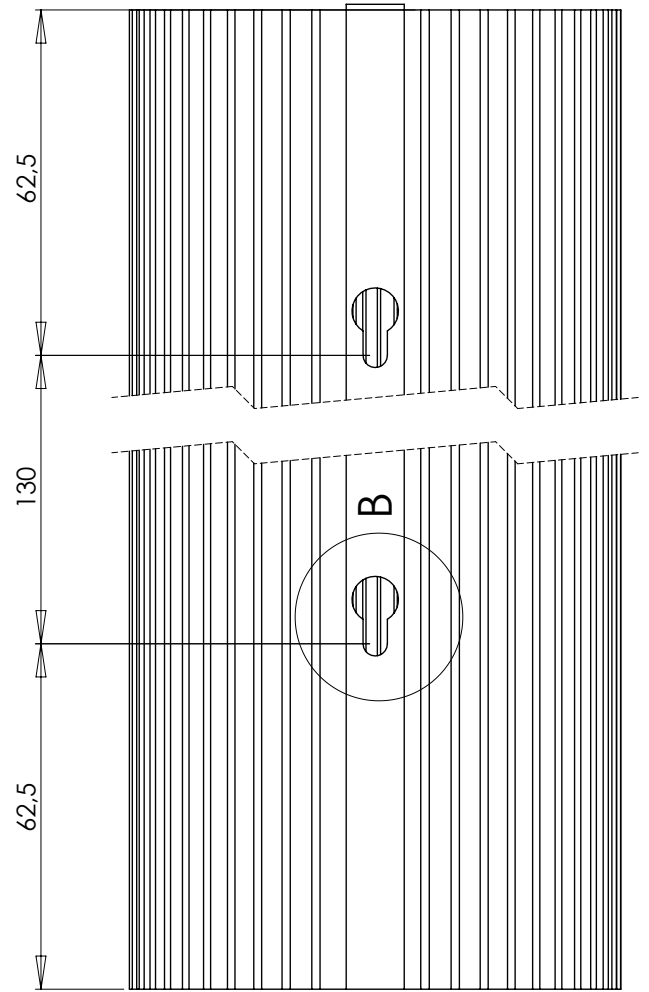
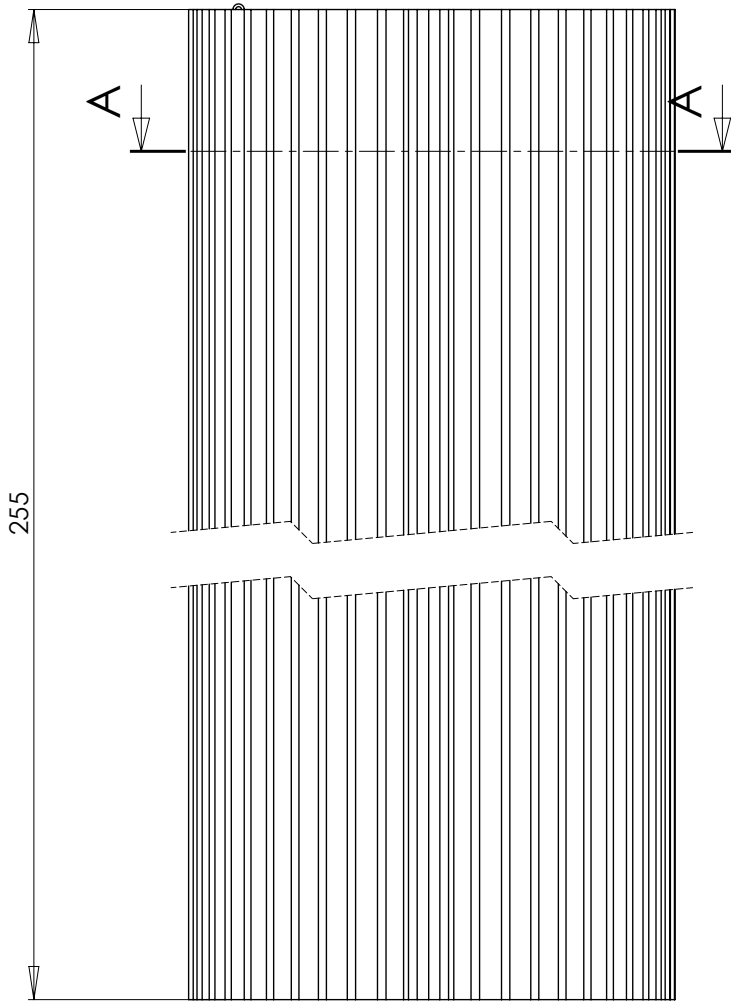

COUPE A-A

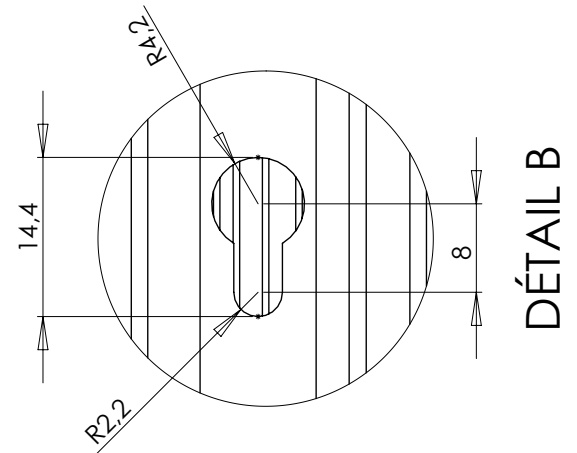

DÉTAIL B

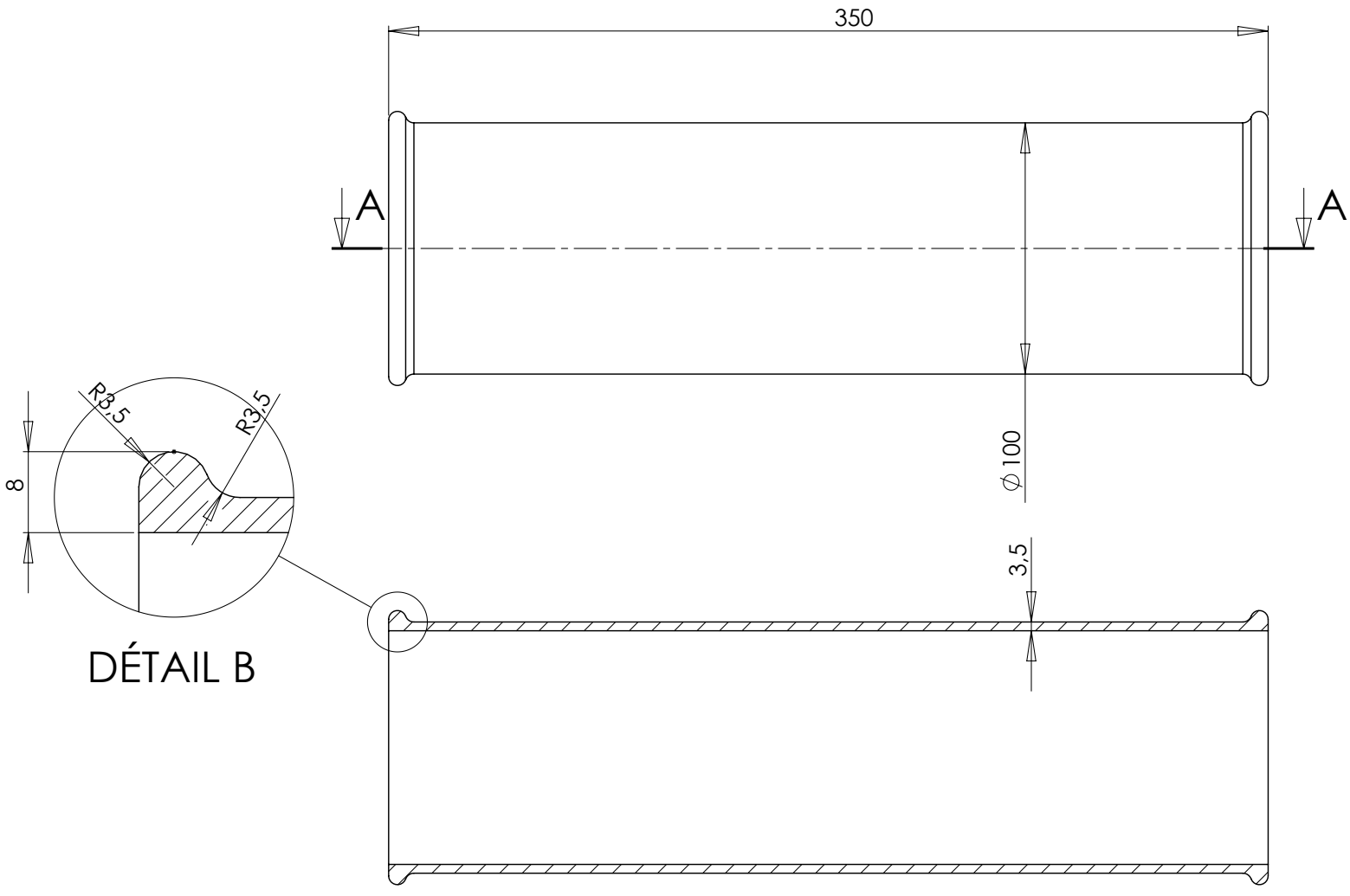

<b>RANGE</b> : BALISE	<b>REF</b> : 100-350	<b>MATERIAL/FINISHING</b> : TRANSPARENT BOROSILICATE GLASS
<b>PART</b> : VERRE		
<b>REV N°</b> : 2		