

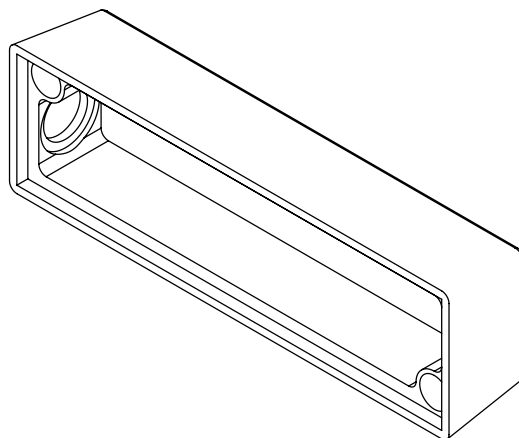

DCW
ÉDITIONS

RANGE : BALISE	REF :	MATERIAL/FINISHING :
PART : BALISE 100-700 CH / BALISE 100-700 MESH CH		
REV N° : 1		

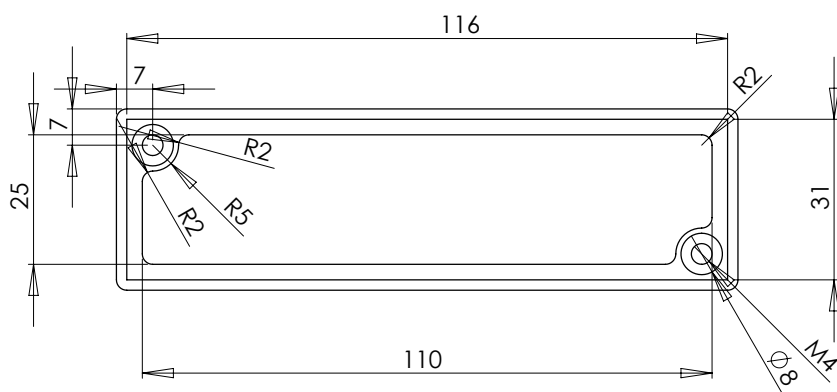

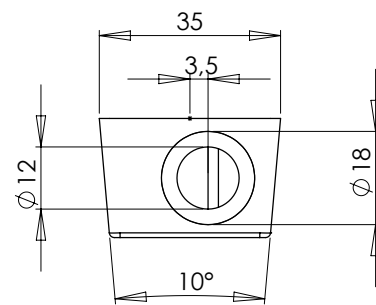
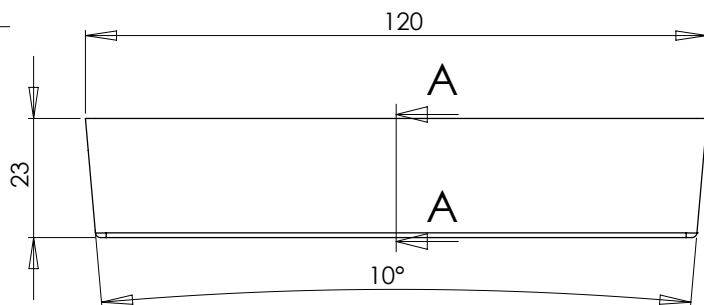
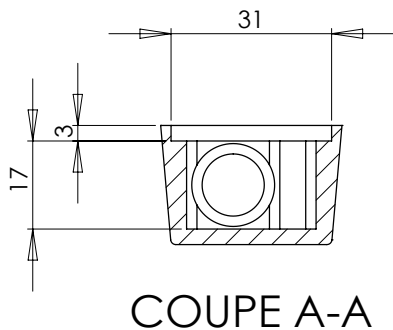
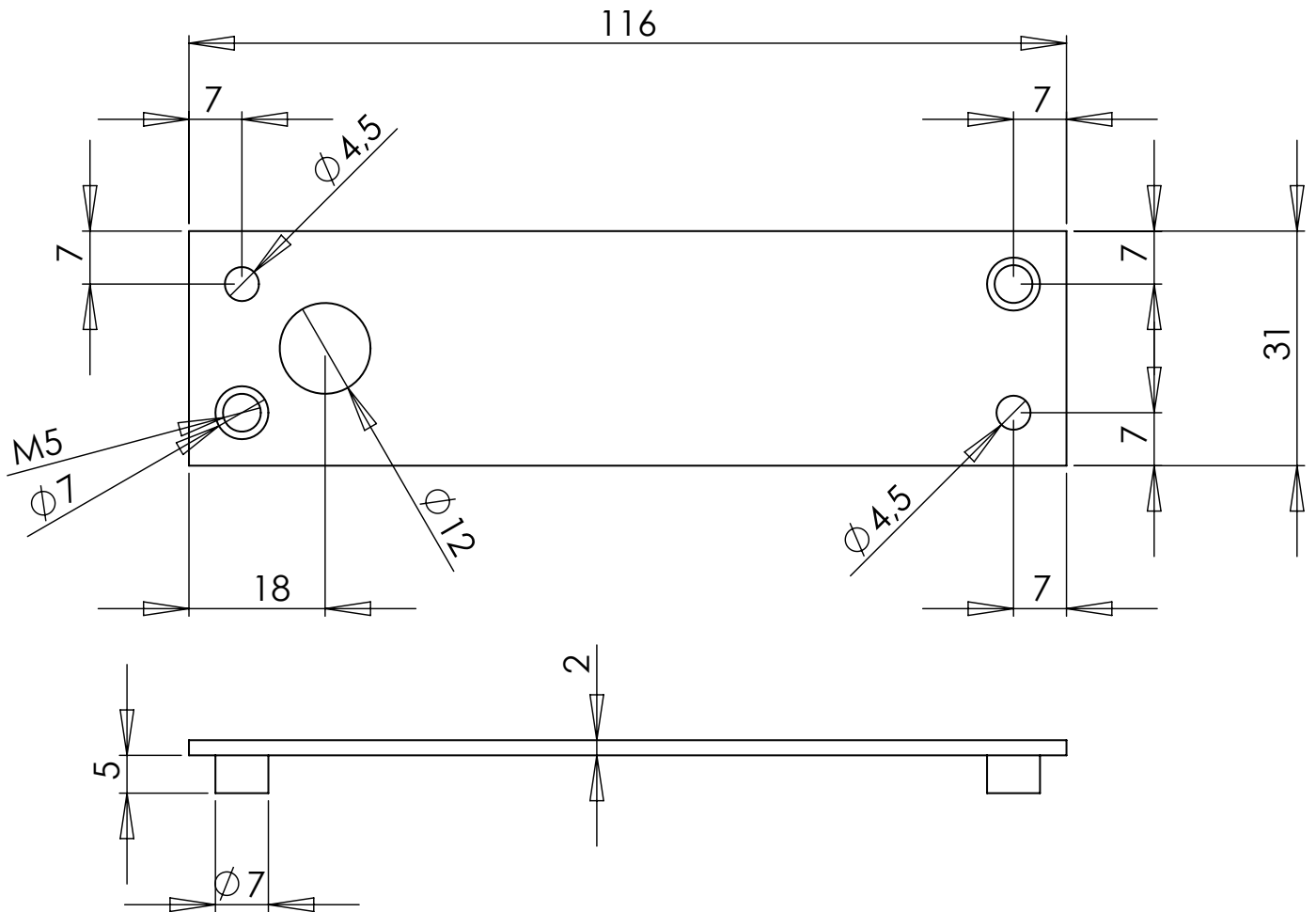

RANGE : BALISE	REF :	MATERIAL/FINISHING : STAINLESS STEEL
PART : TERMINAL BOX COVER		
REV N° : 1		

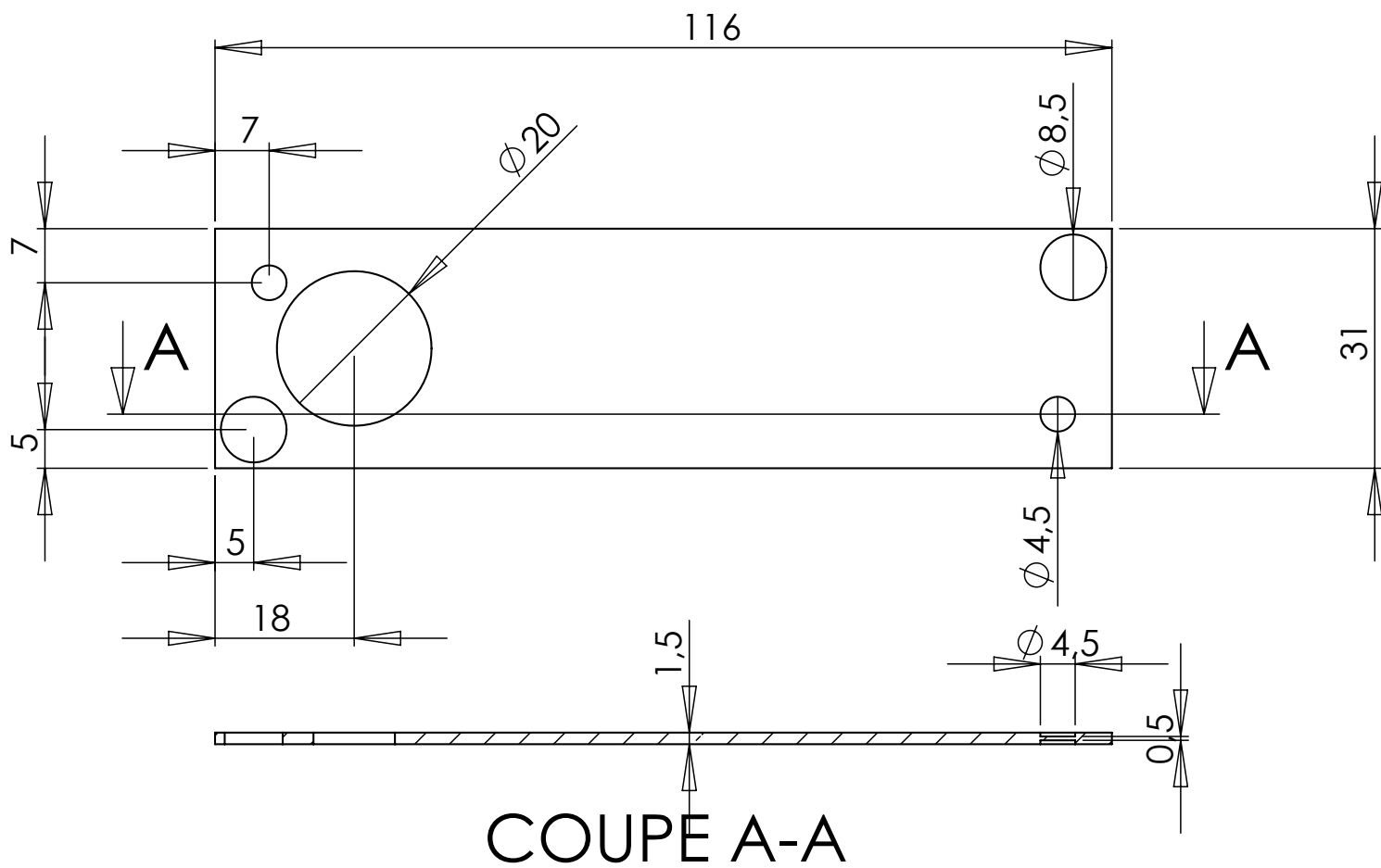

COUPE A-A

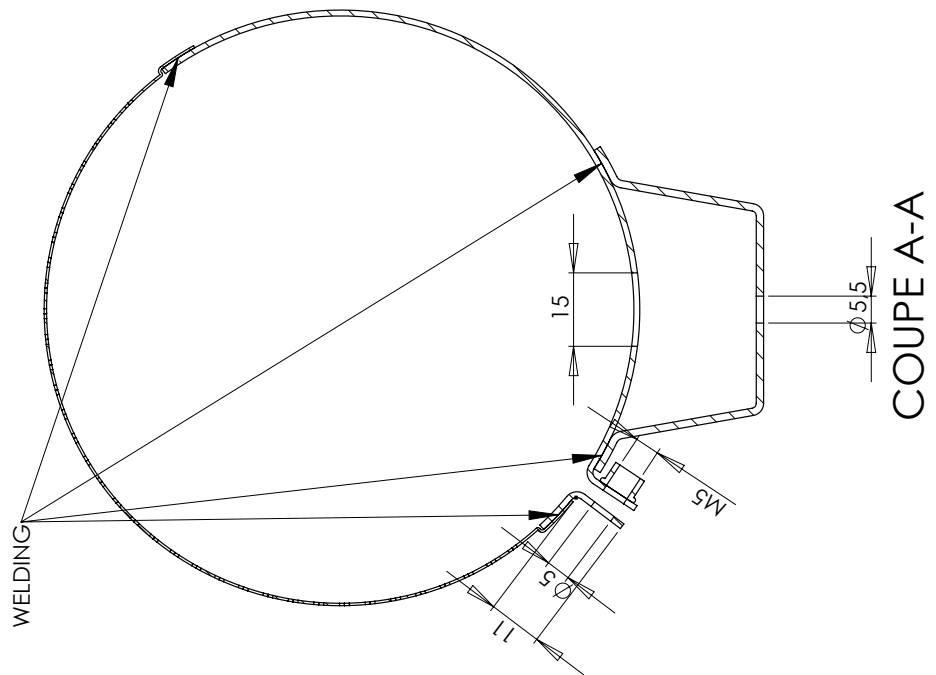
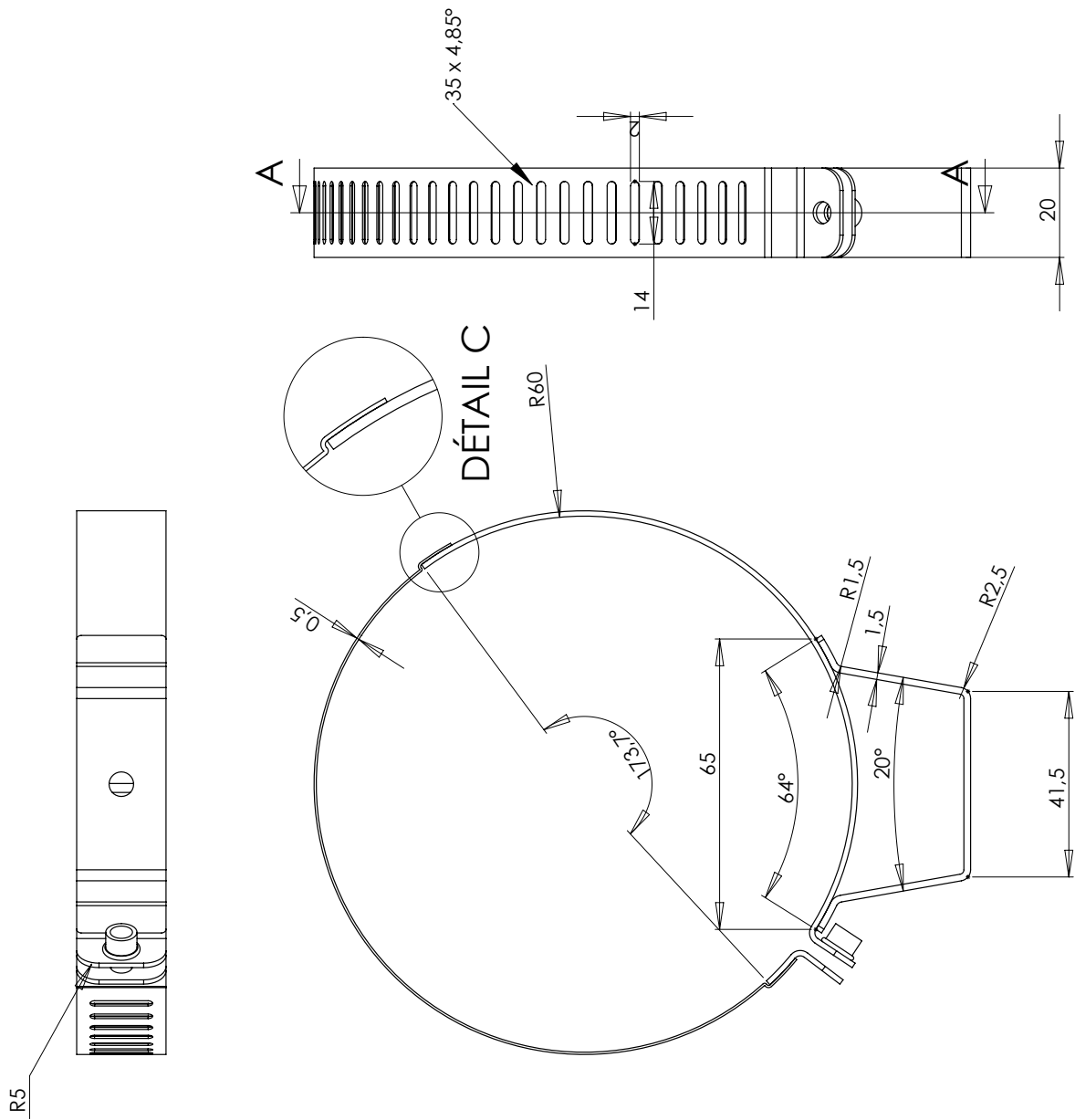

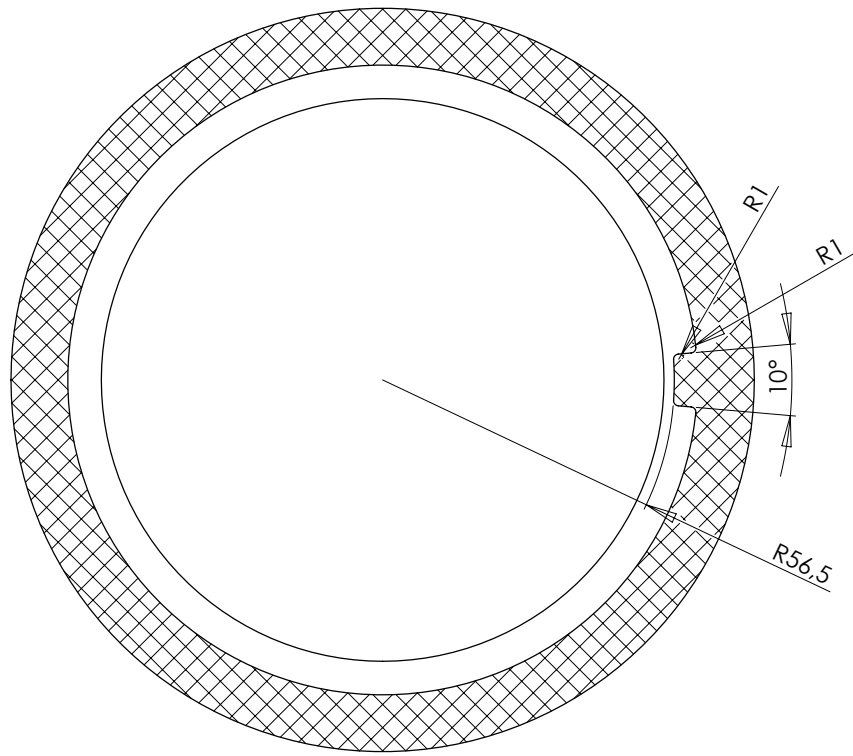

COUPE B-B

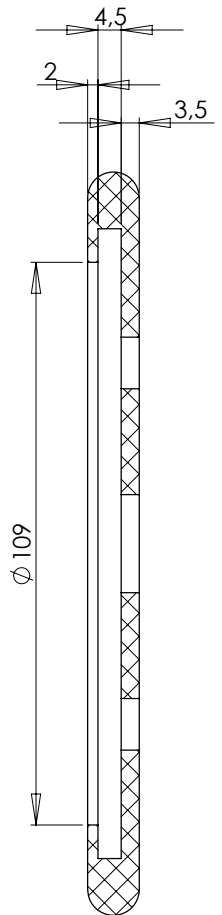
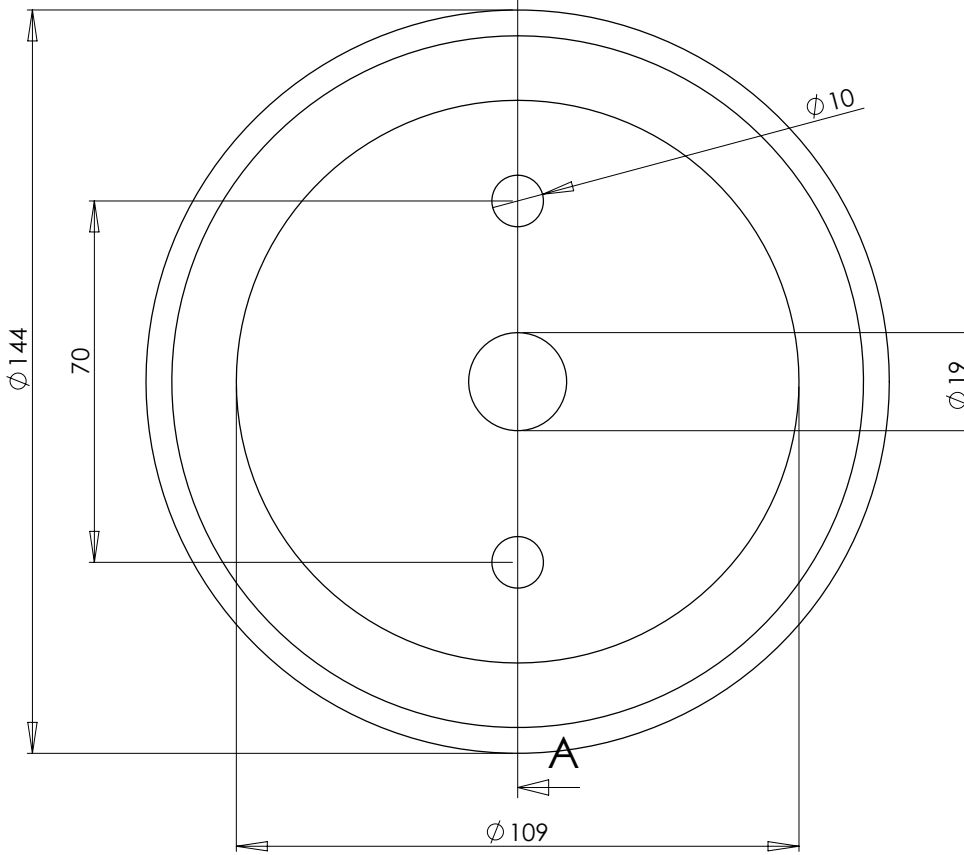
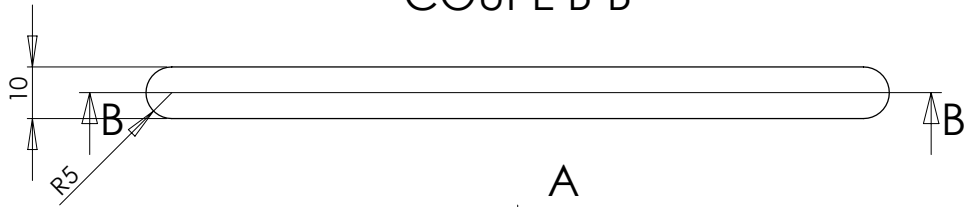

COUPE A-A

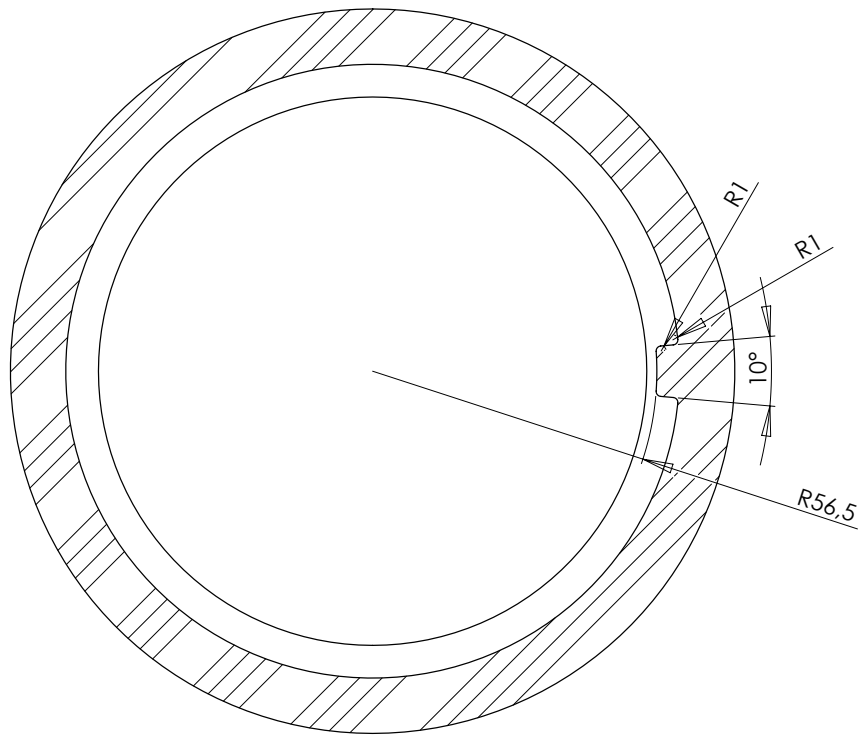

COUPE B-B

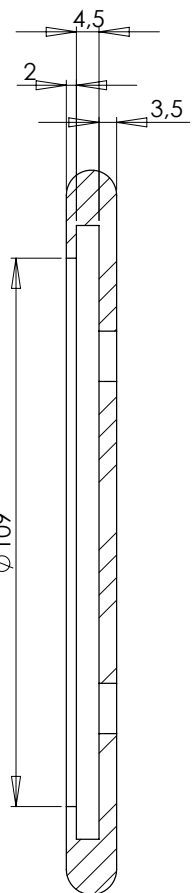
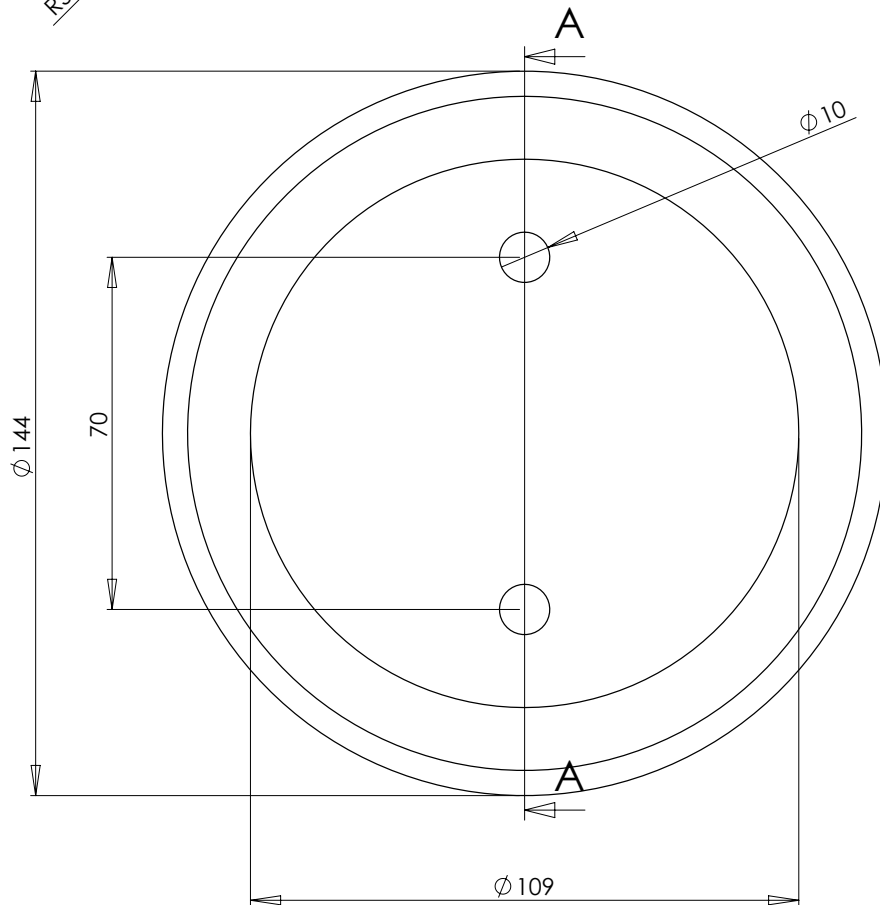
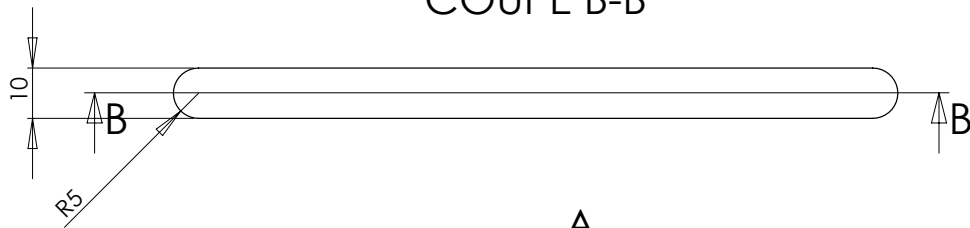

COUPE A-A

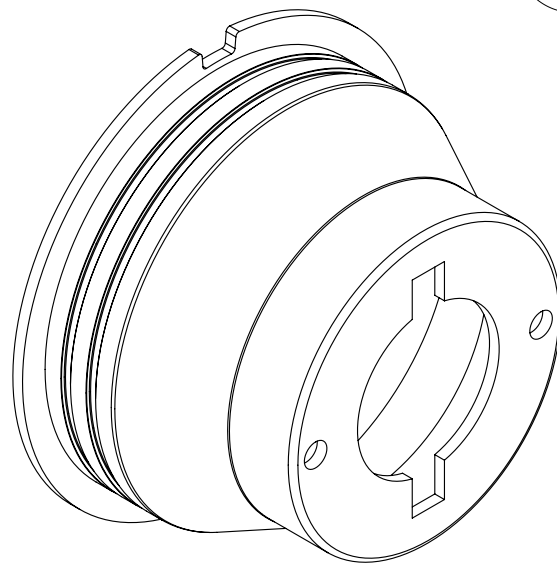
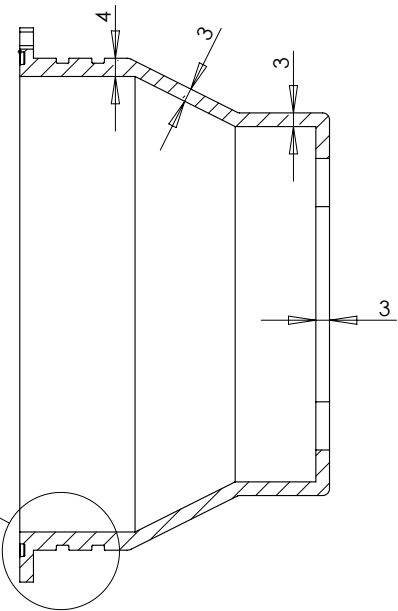
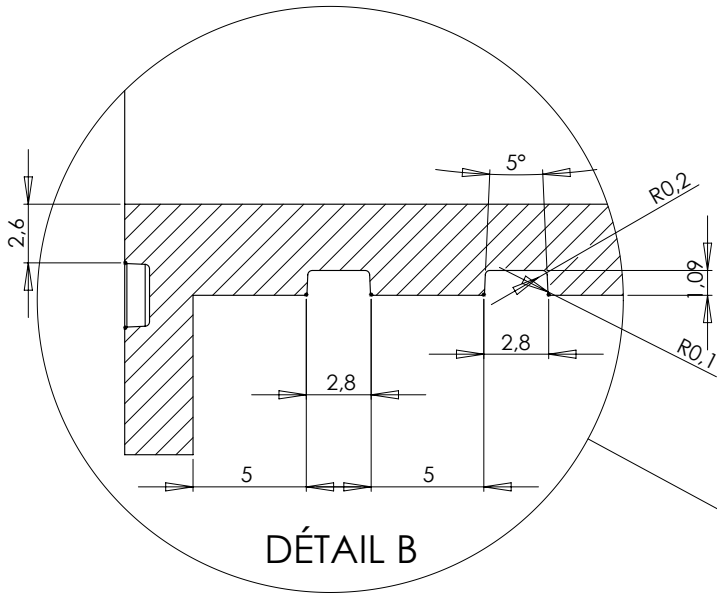
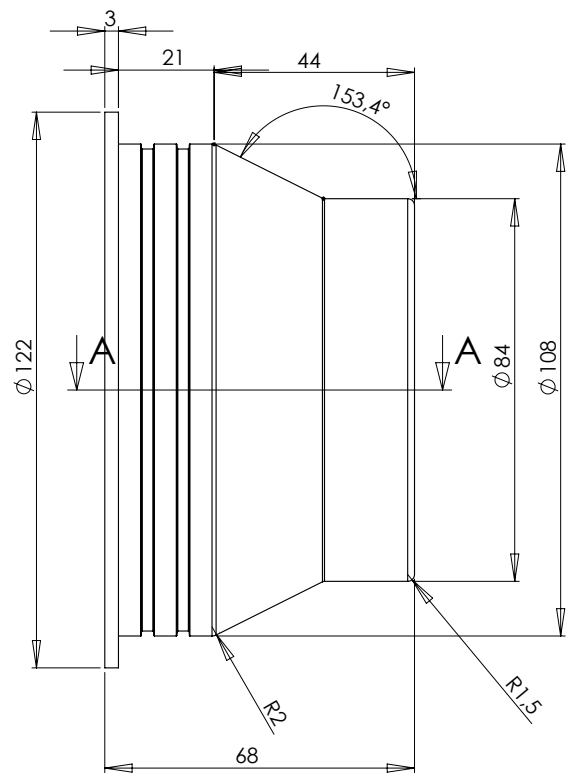
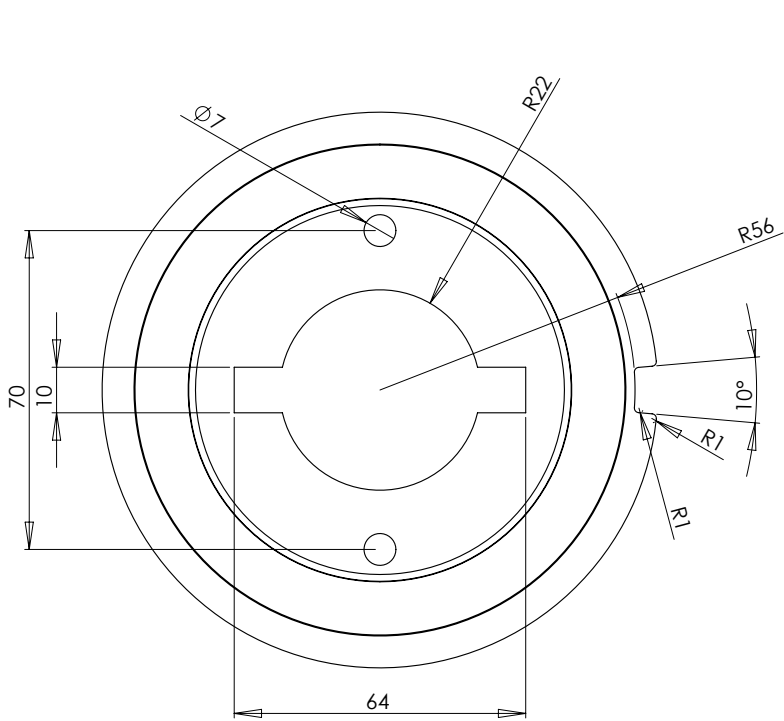

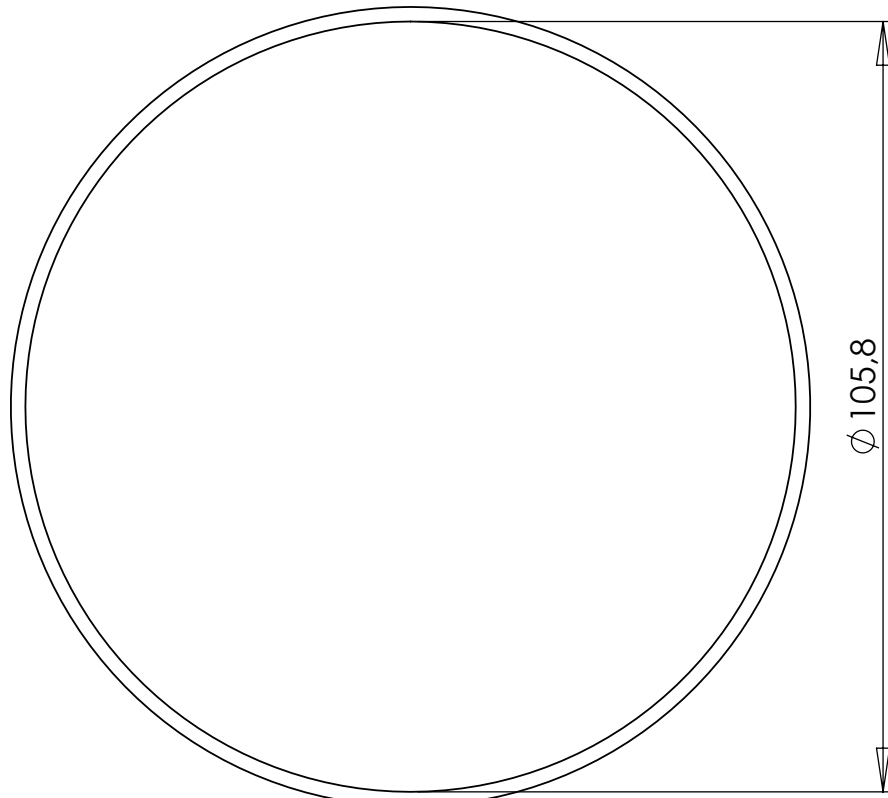
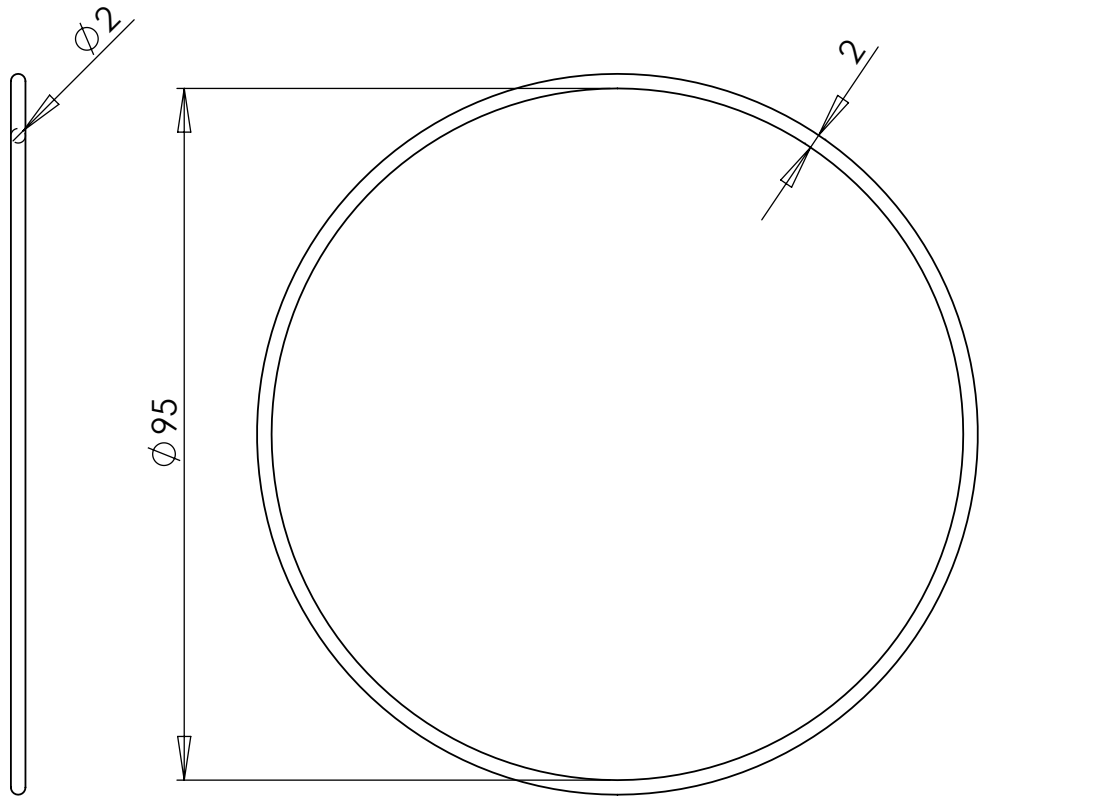

SEAL IN POSITION

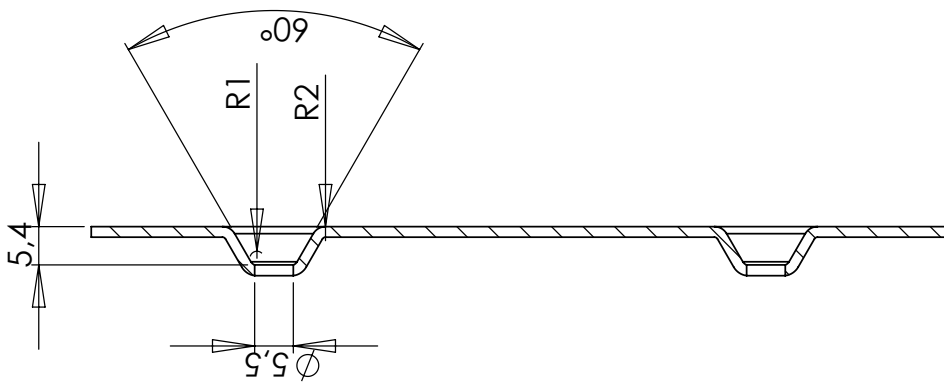
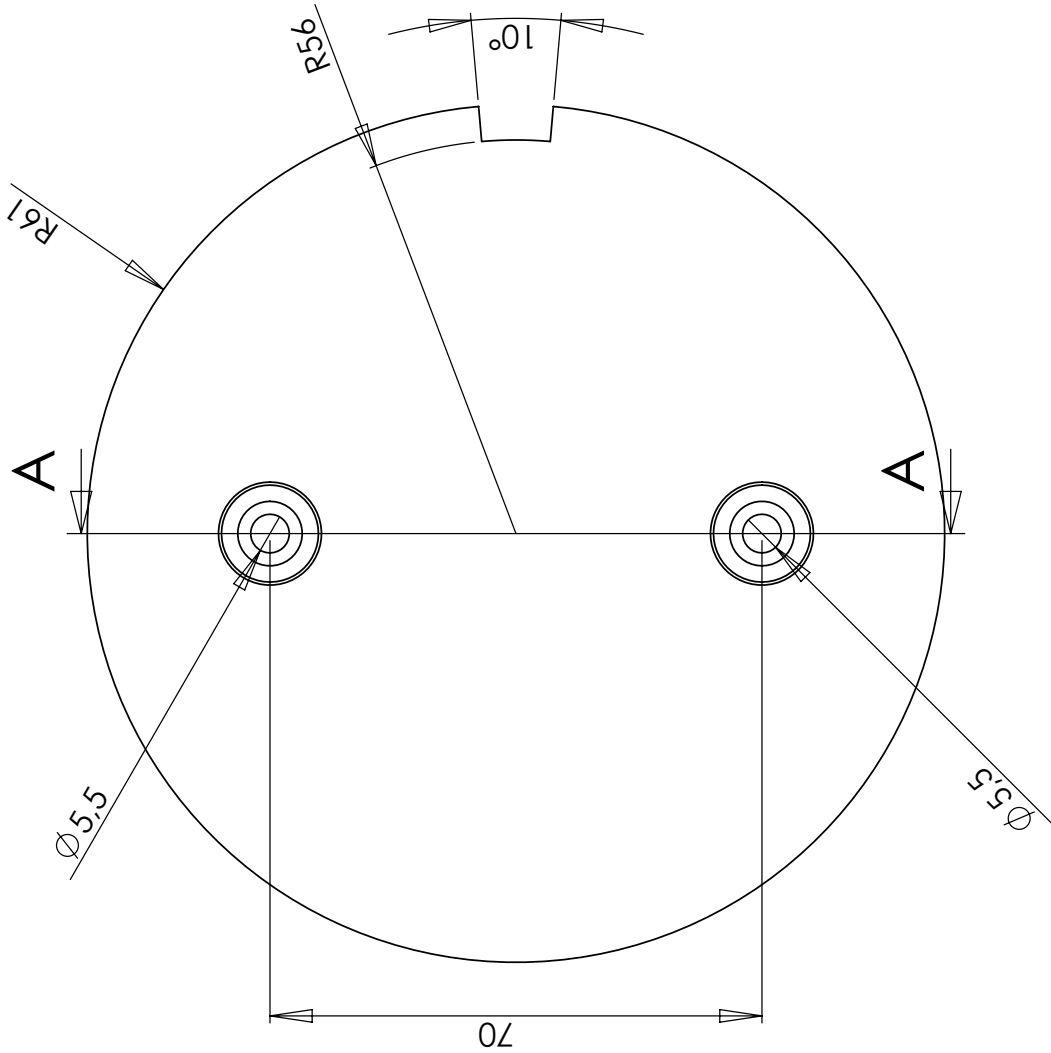
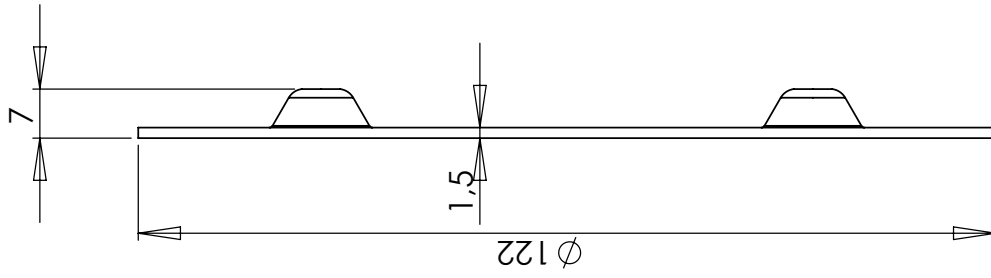

COUPE A-A

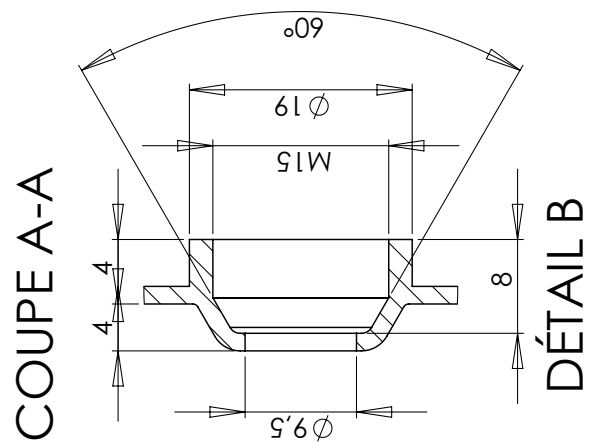
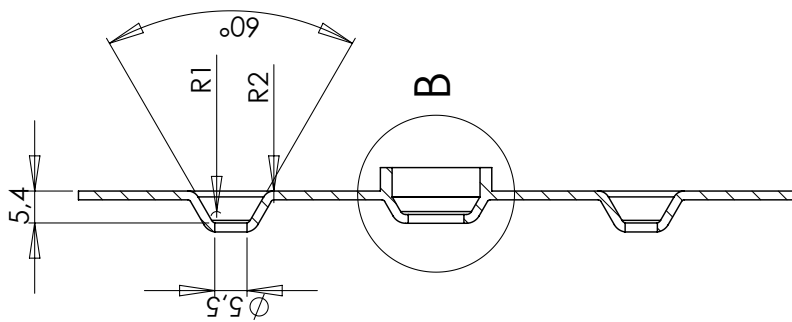
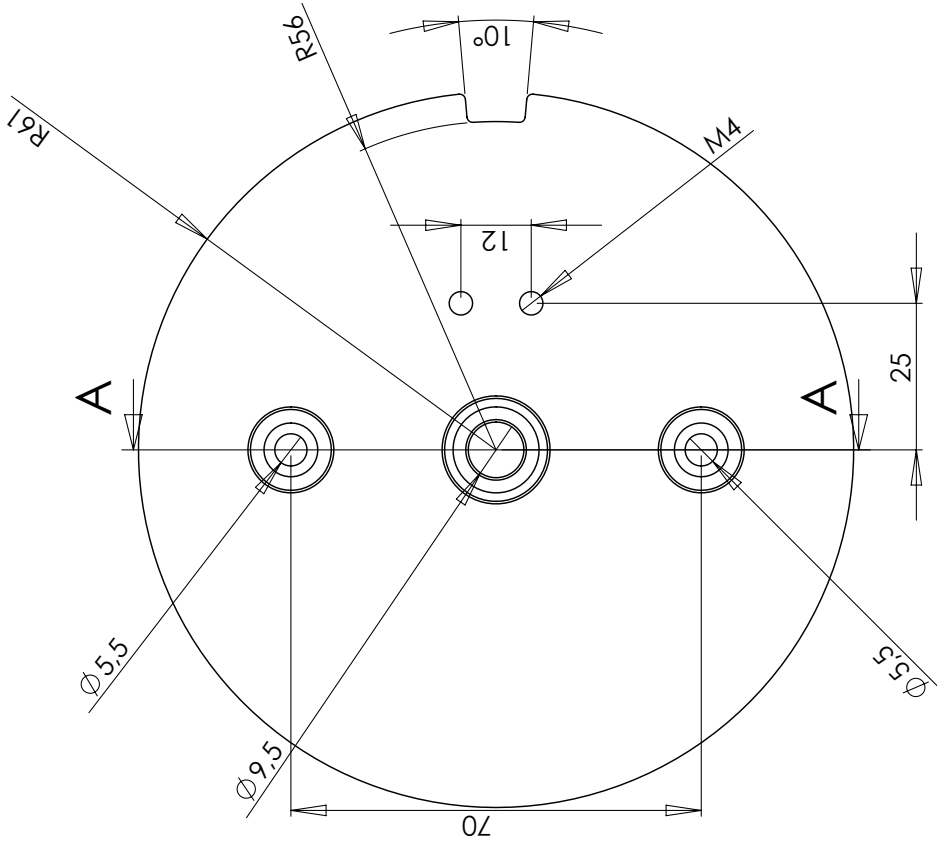
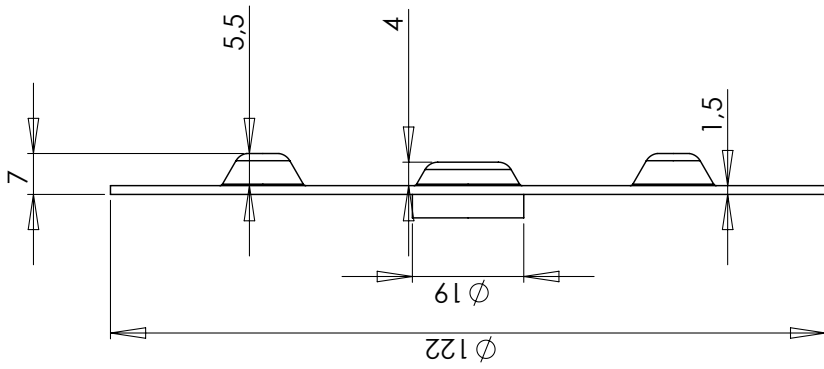

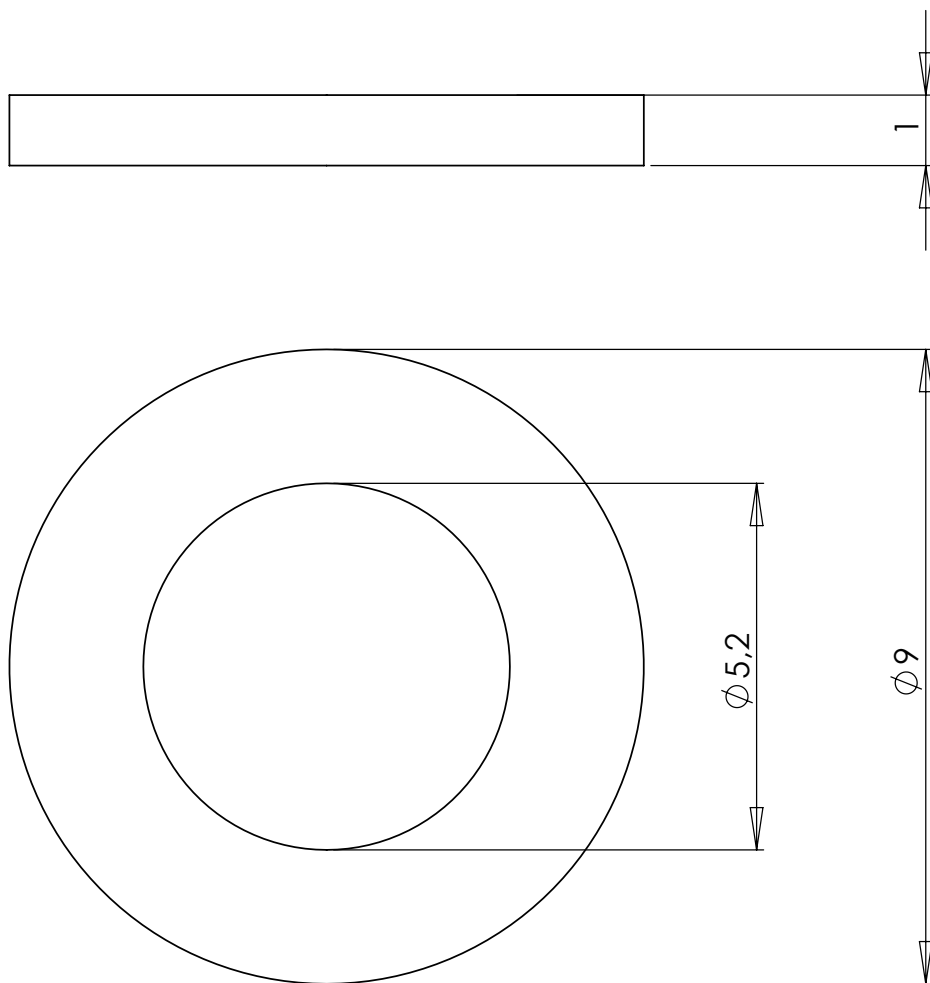

RANGE : BALISE	REF :	MATERIAL/FINISHING : BLACK NYLON
PART : M5 WASHER		
REV N° : 1		

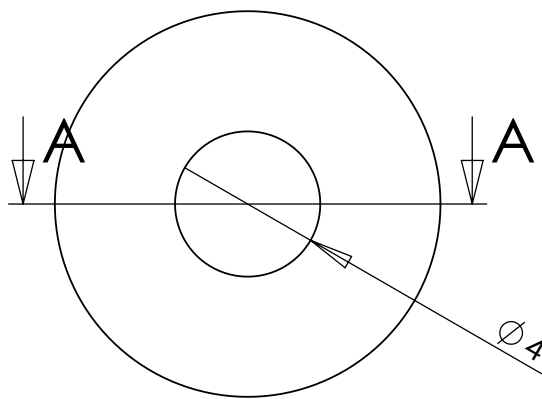
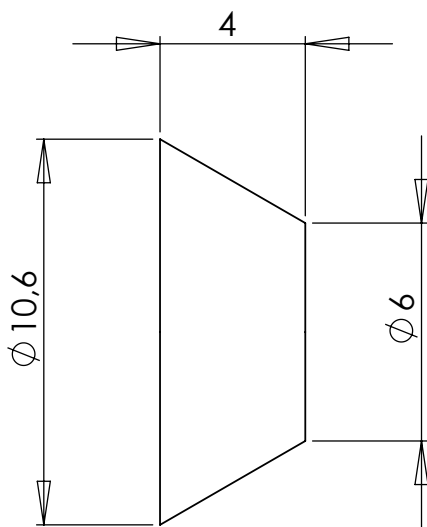

COUPE A-A

RANGE : BALISE	REF :	MATERIAL/FINISHING : BLACK SILICONE
PART : M5 SEAL		
REV N° : 1		

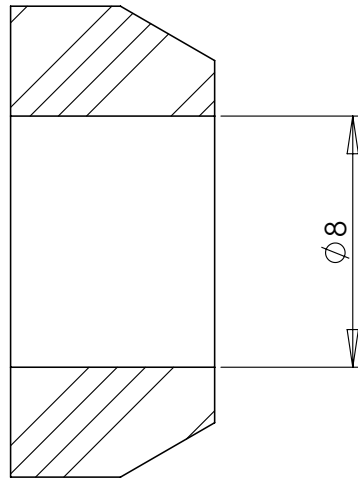
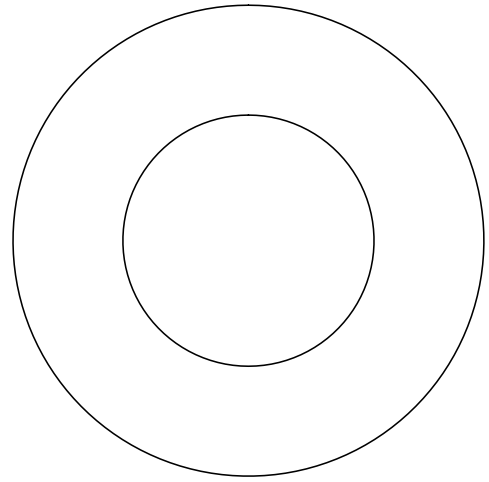
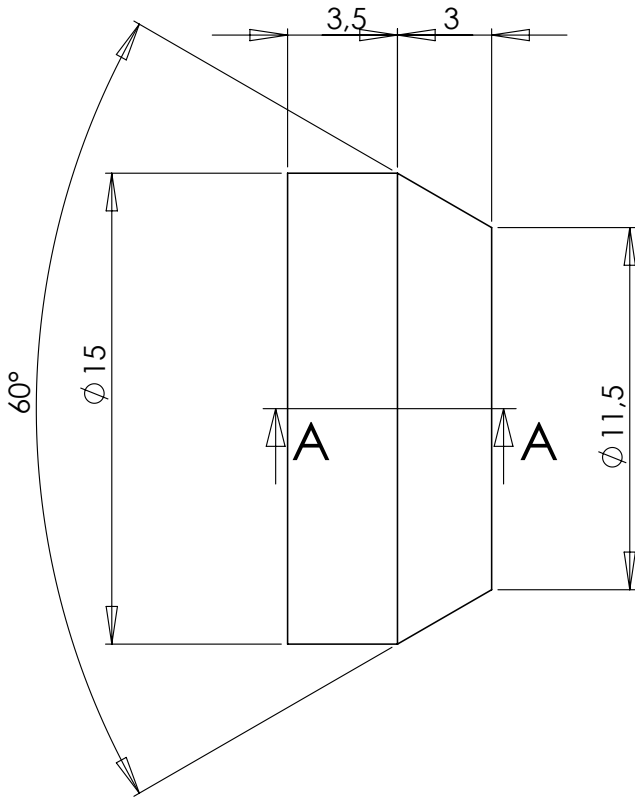

COUPE A-A

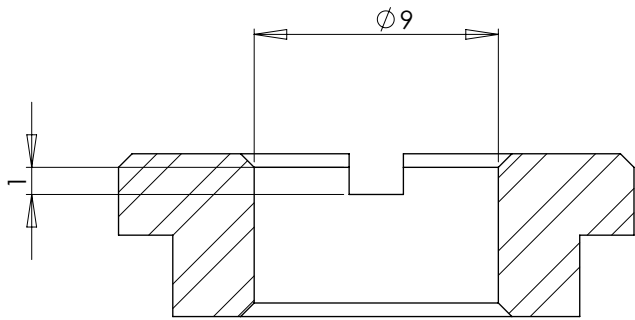

COUPE A-A

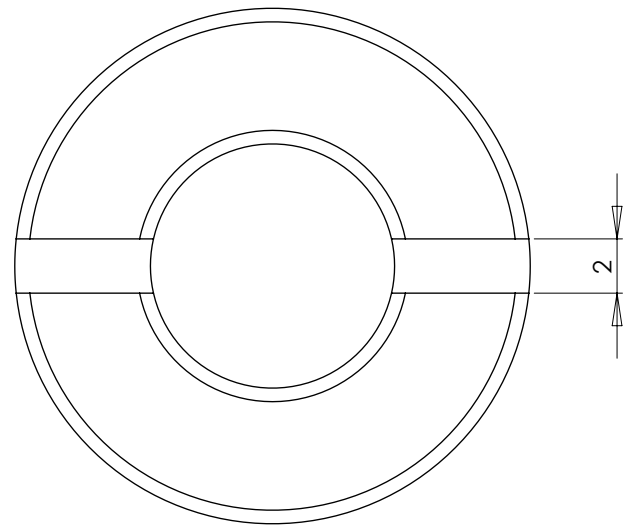
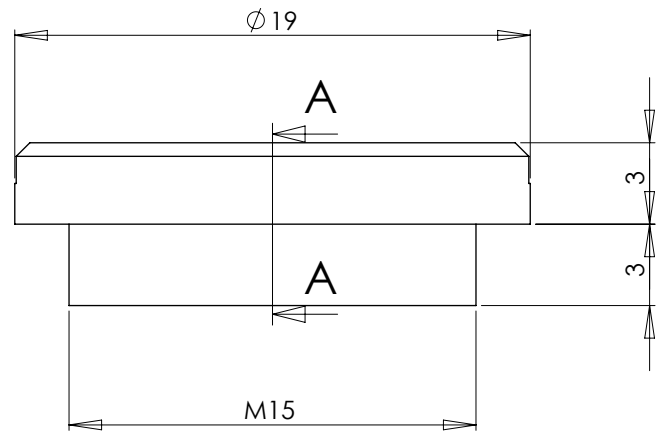

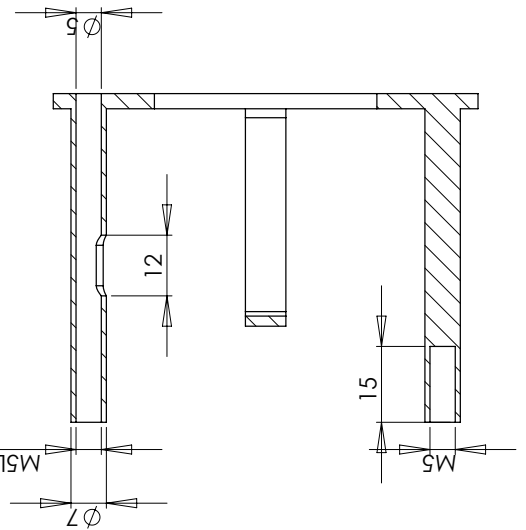
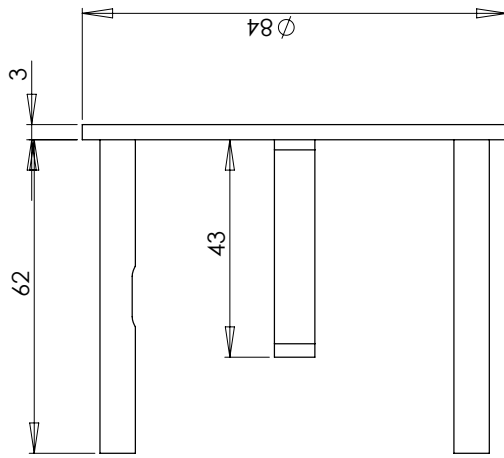
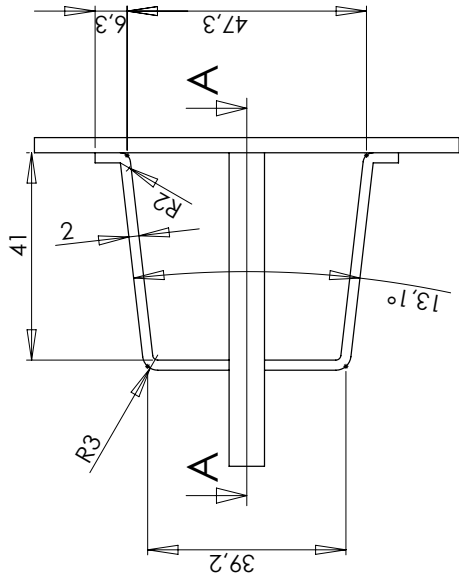
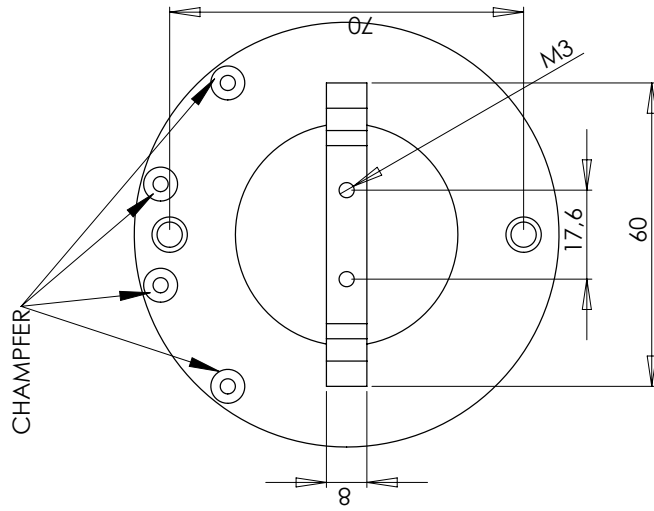

COUPE A-A

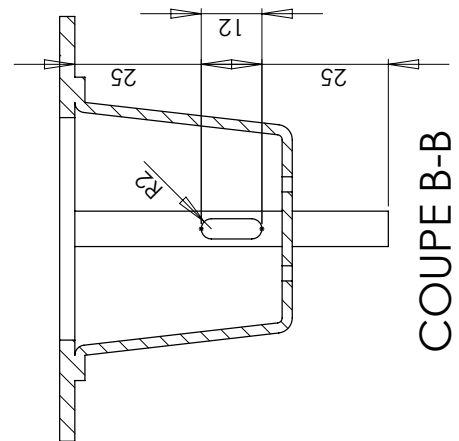
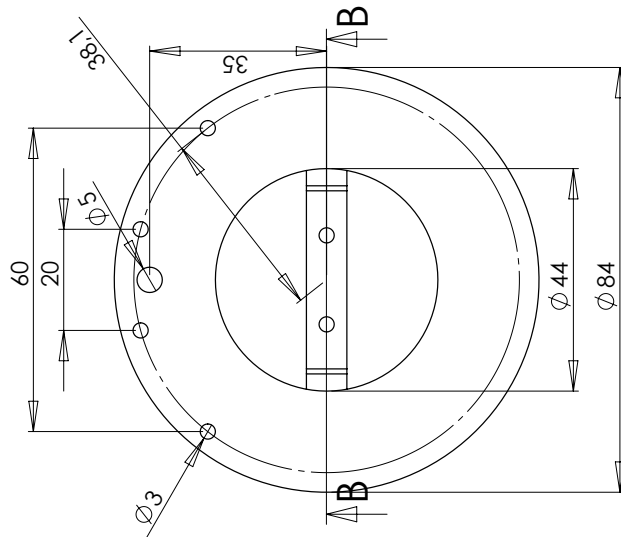

COUPE B-B

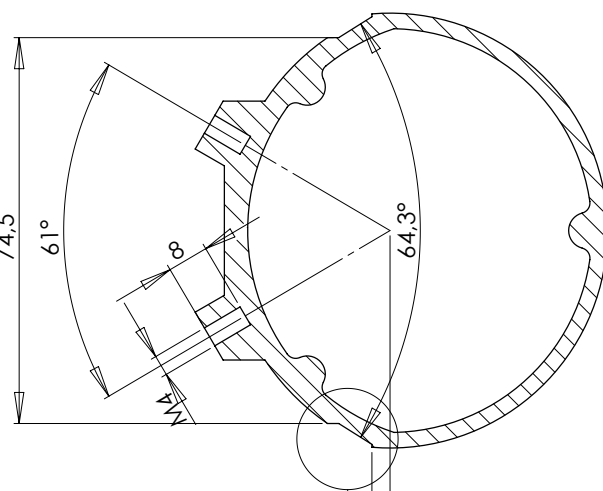
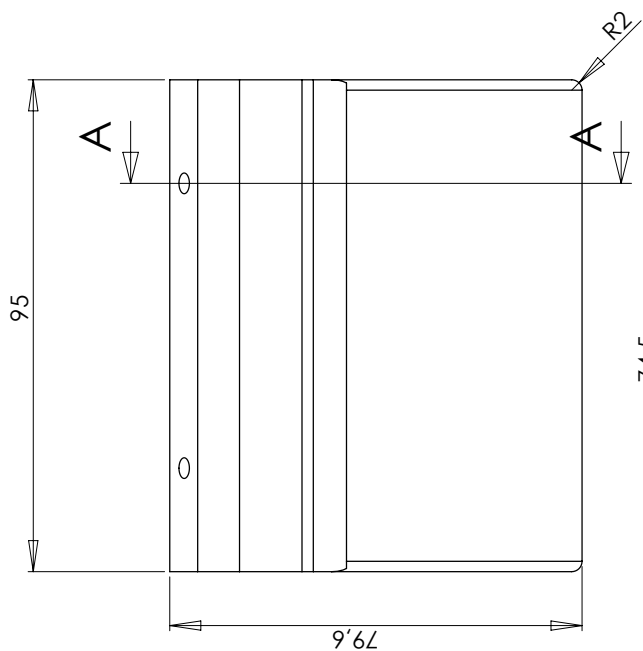
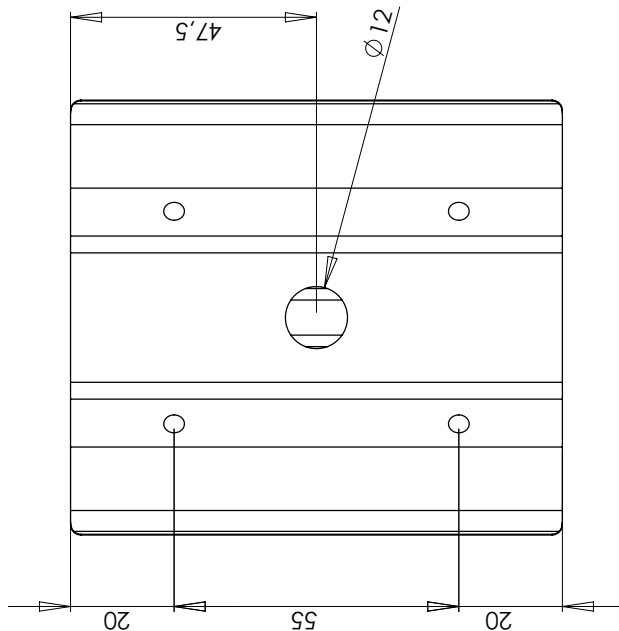
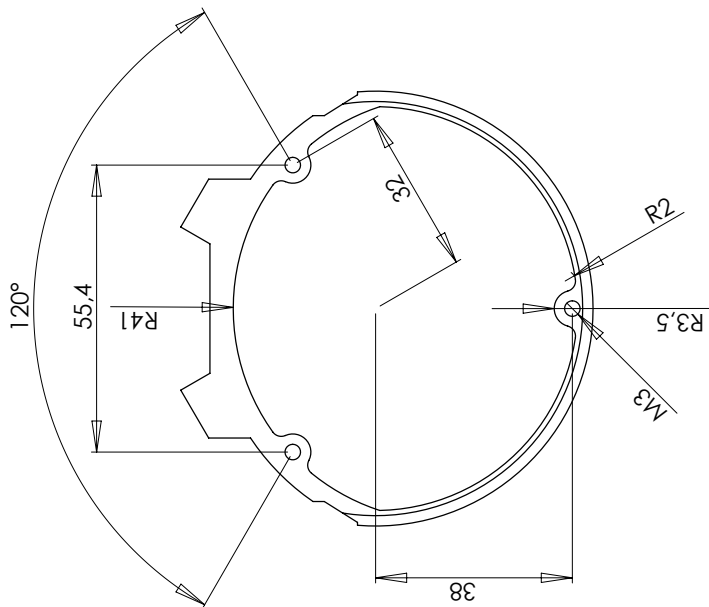

COUPE A-A

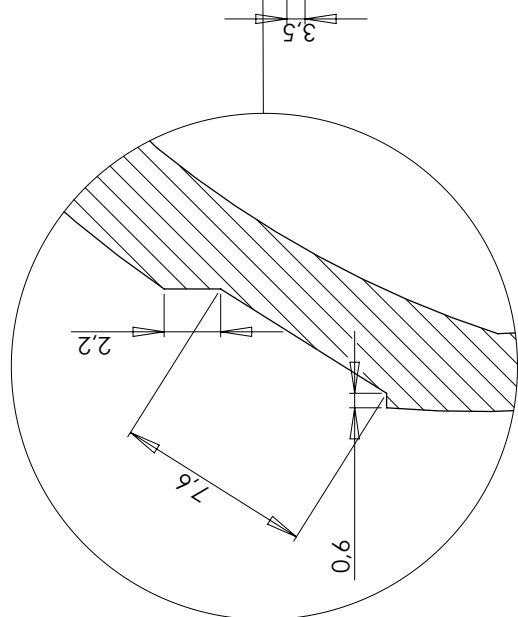
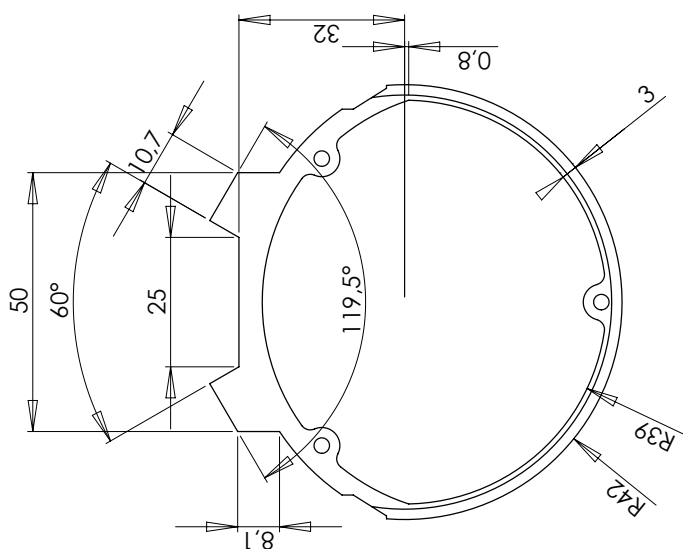

DÉTAIL B

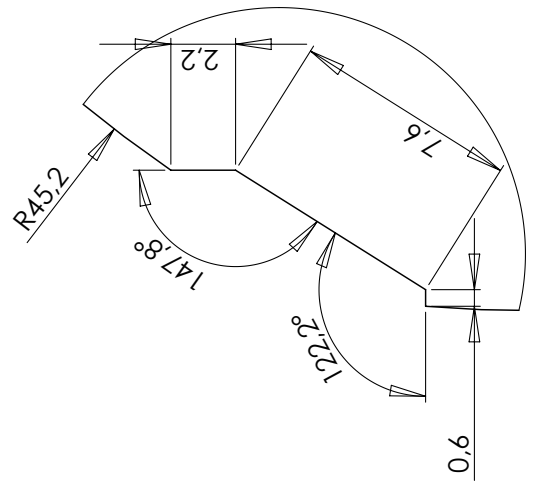
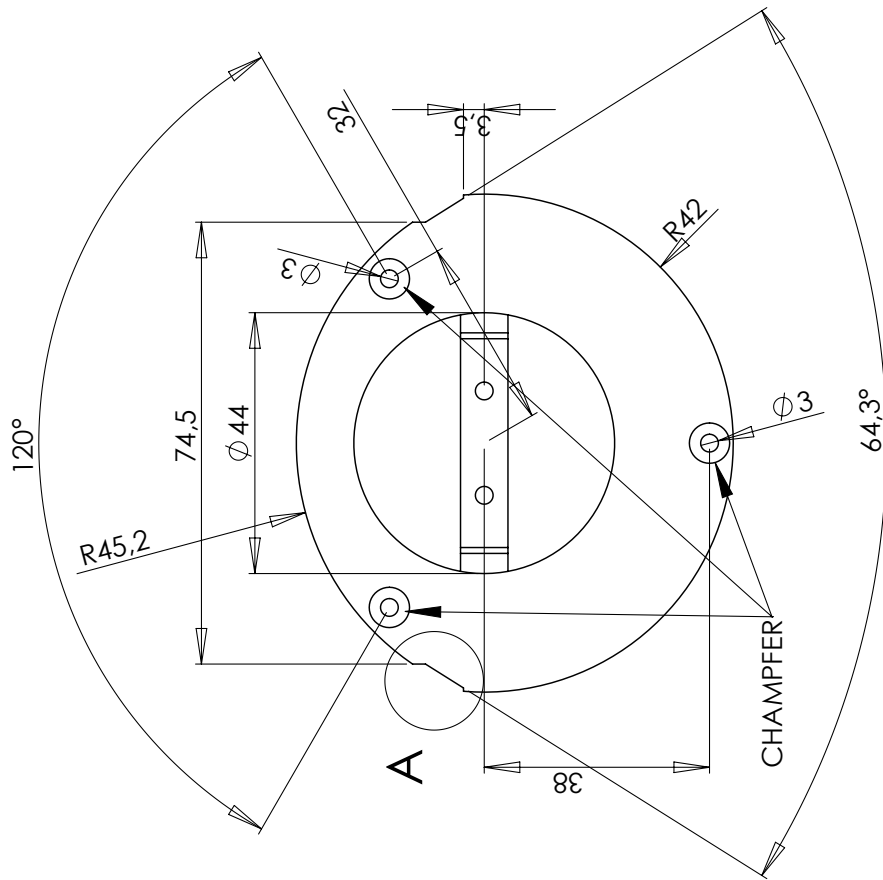
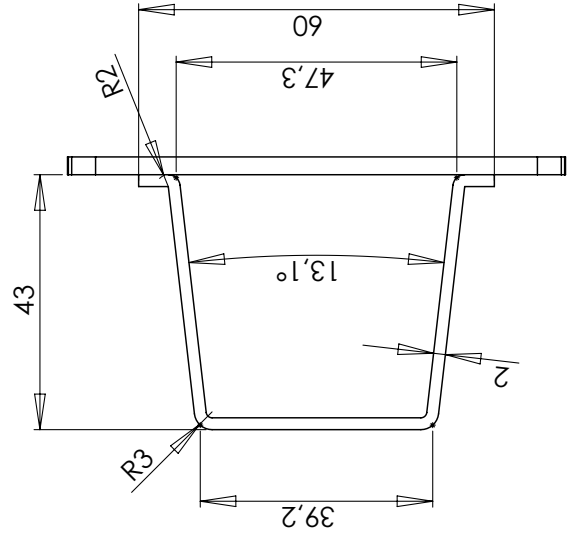
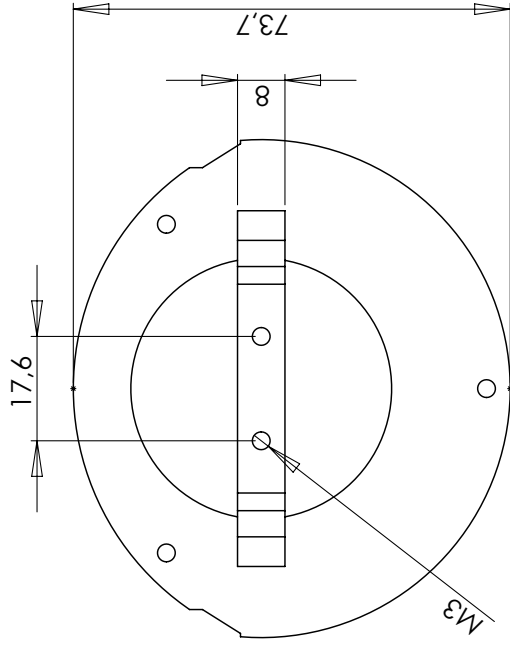

DÉTAIL A

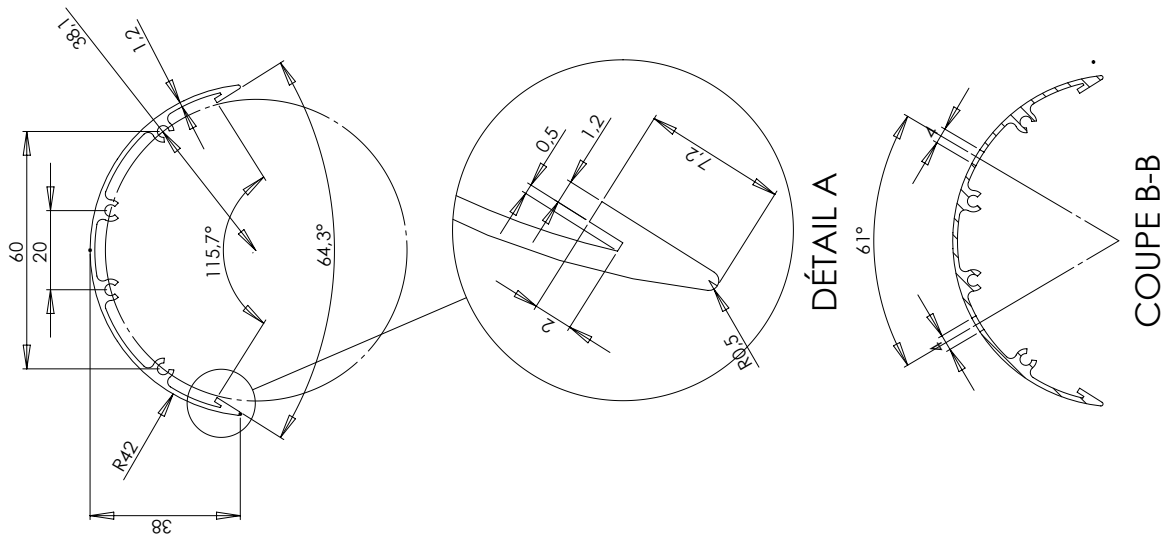
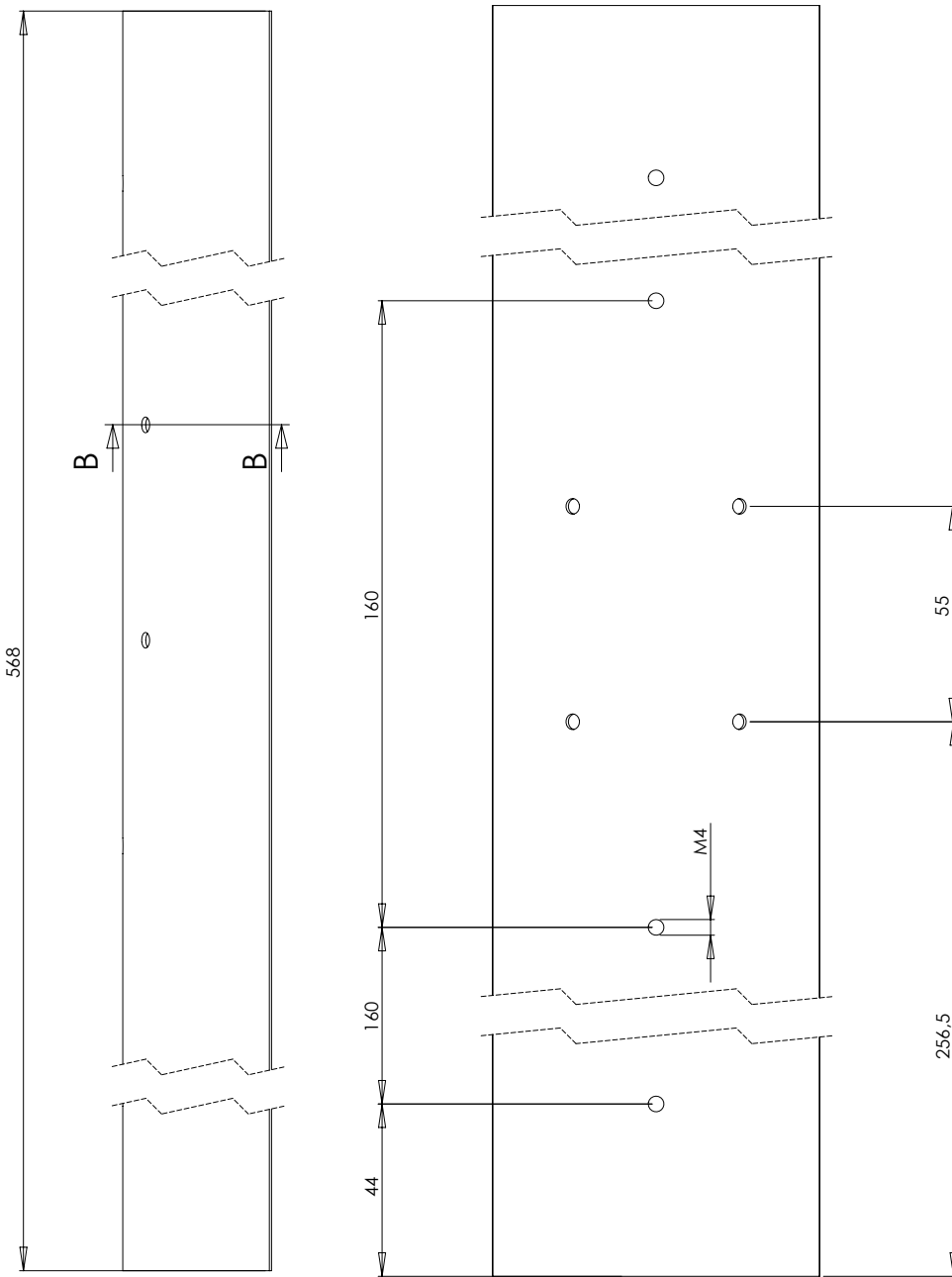

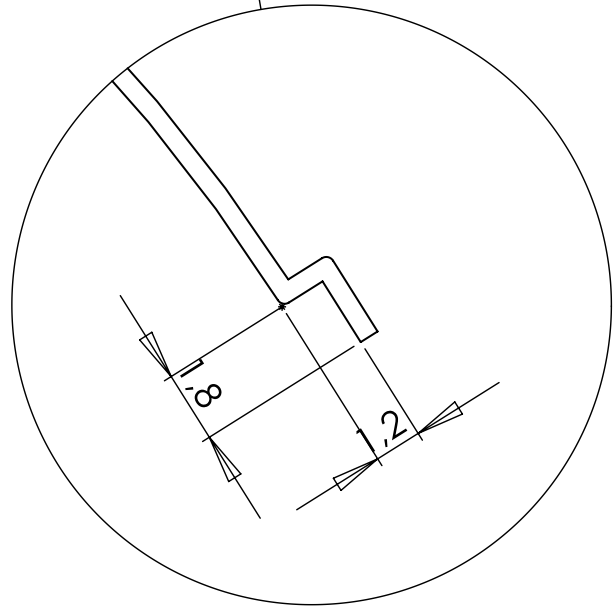
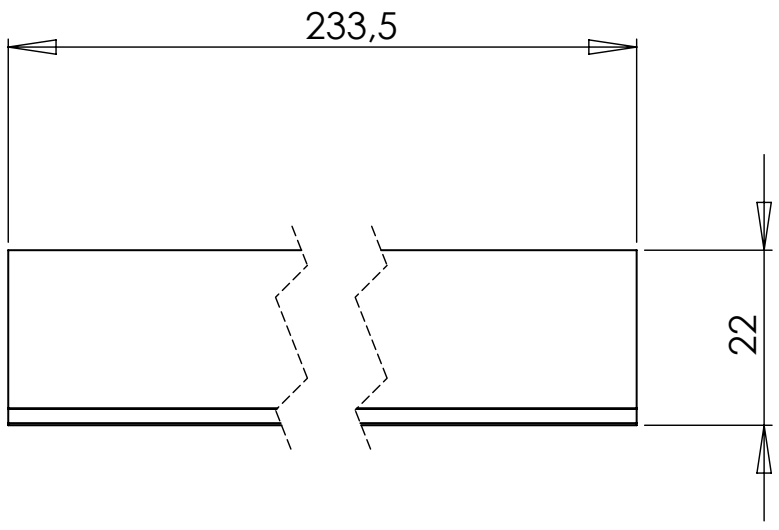
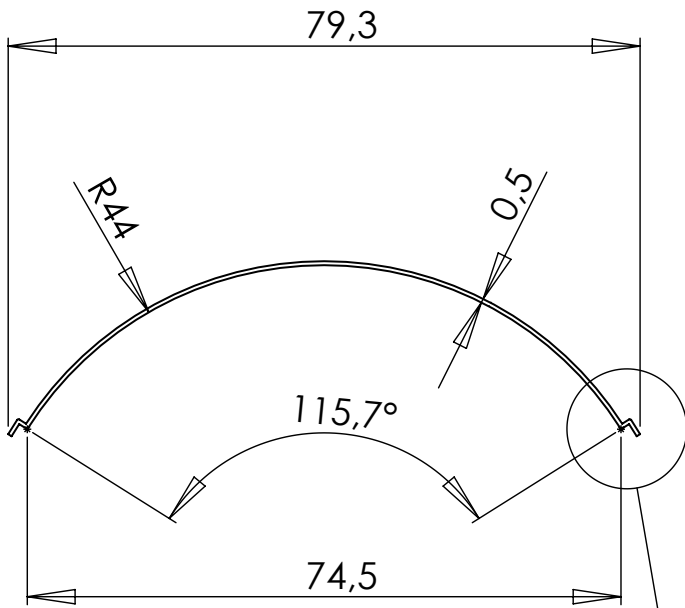

DÉTAIL A

RANGE : BALISE	REF : 120 - 700	MATERIAL/FINISHING : STEEL / SATIN CHROME; COPPERE- D; BRASSED
PART : REFLECTOR SHEET		
REV N° : 1		

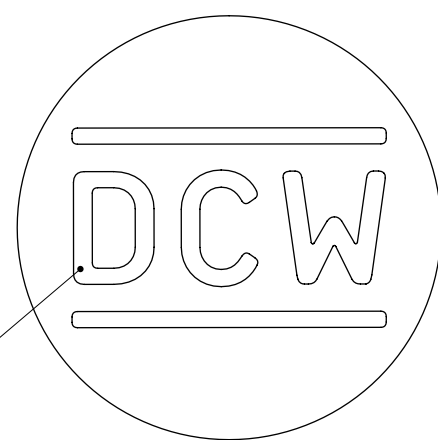
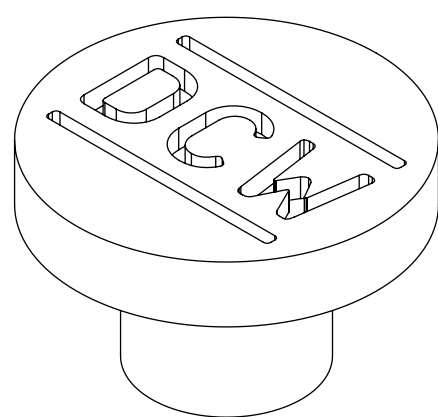
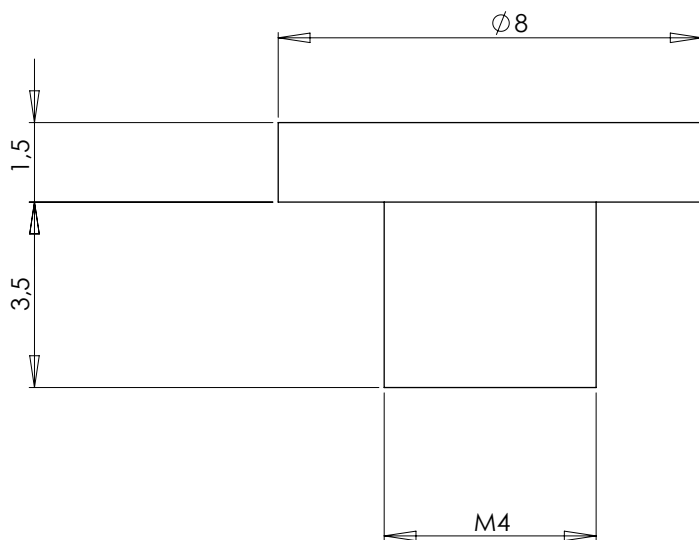

Engraved DCW logo



RANGE : BALISE	REF :	MATERIAL/FINISHING : STEEL CAST / SATIN CHROME; COPPERE- D; BRASSED
PART : TITON		
REV N° : 1		

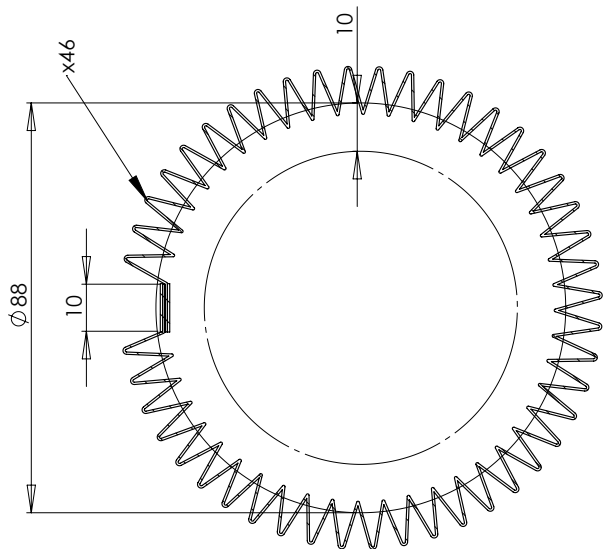
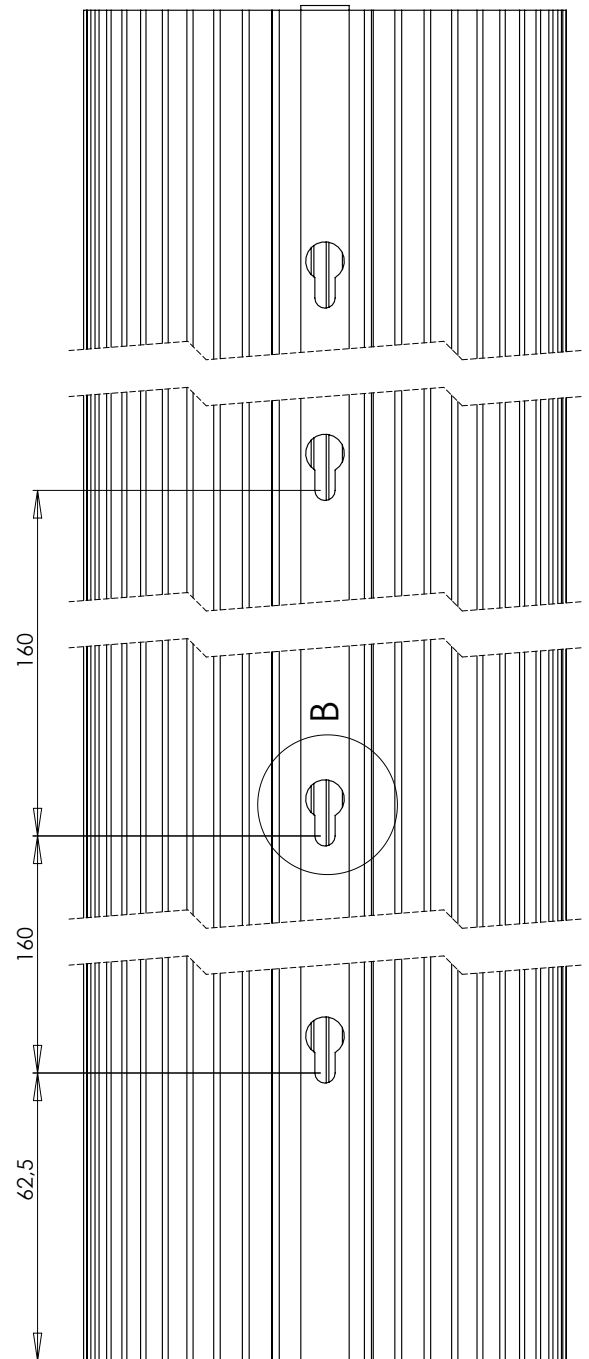
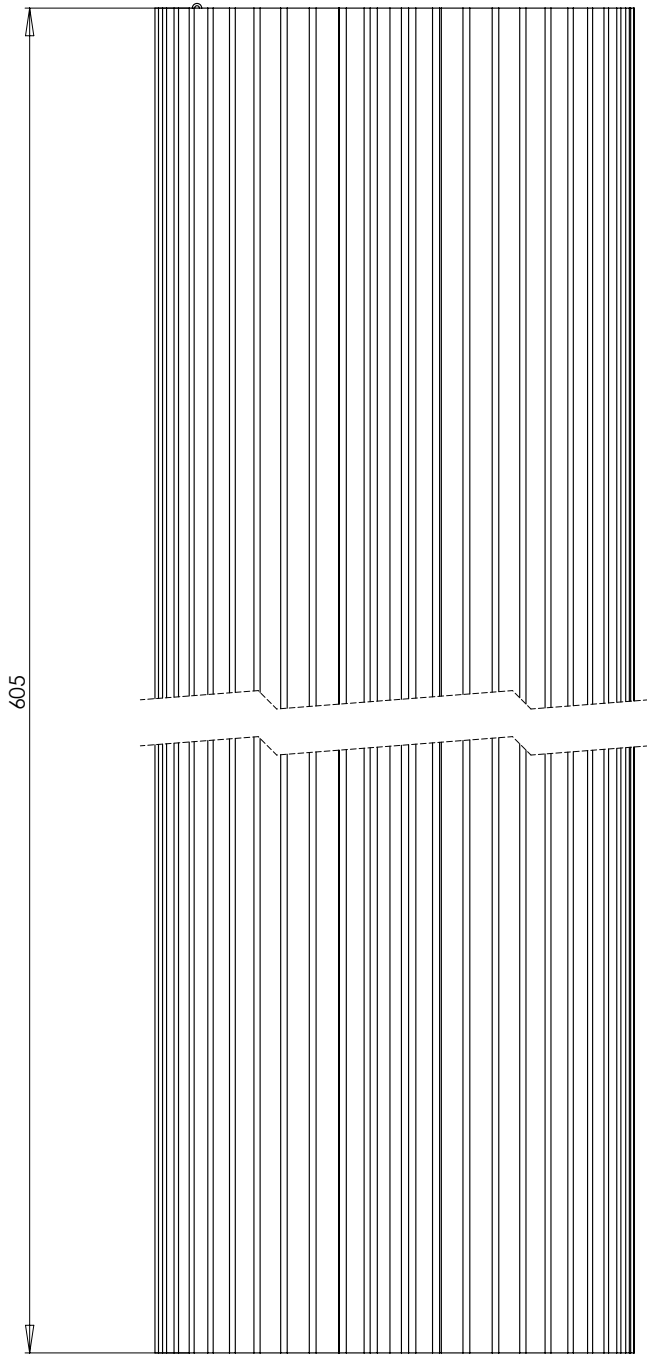

COUPE A-A

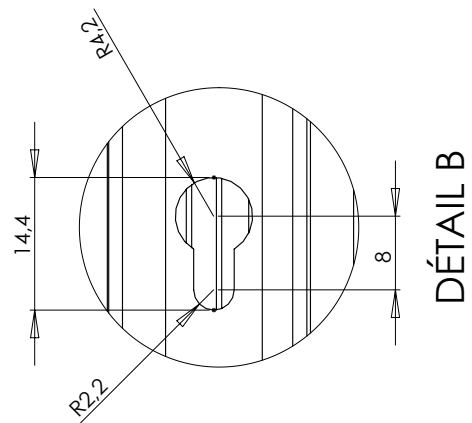

DÉTAIL B

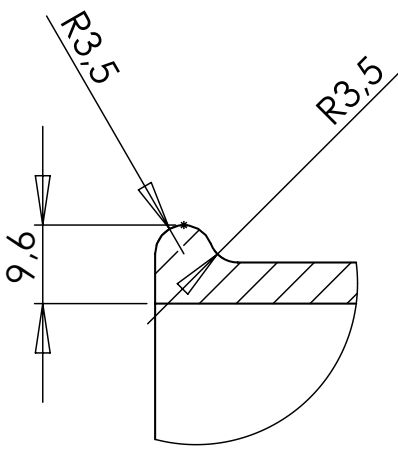
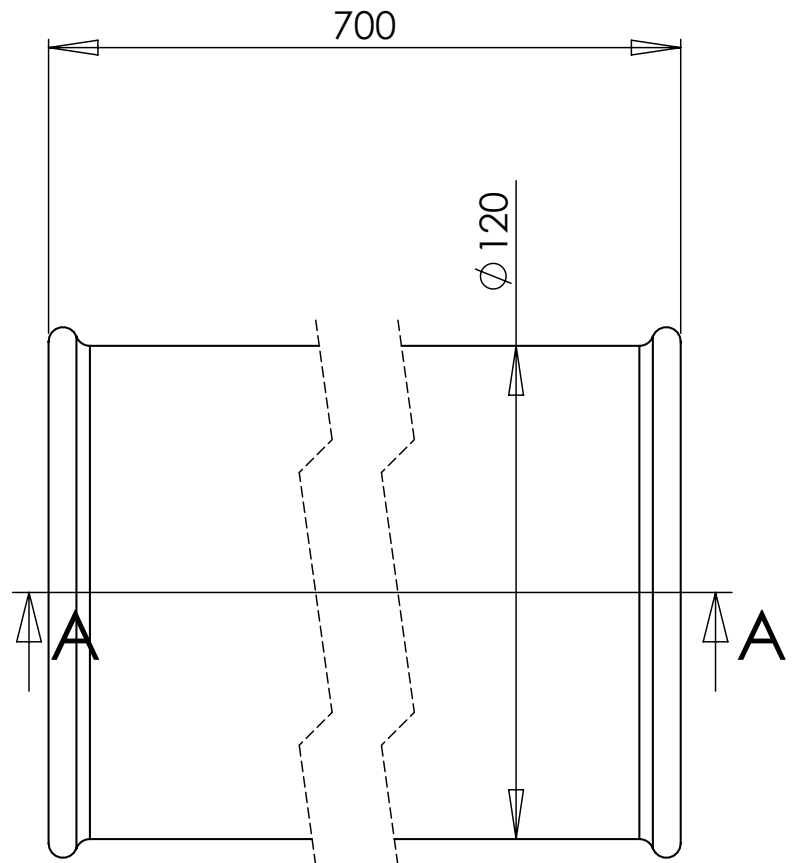
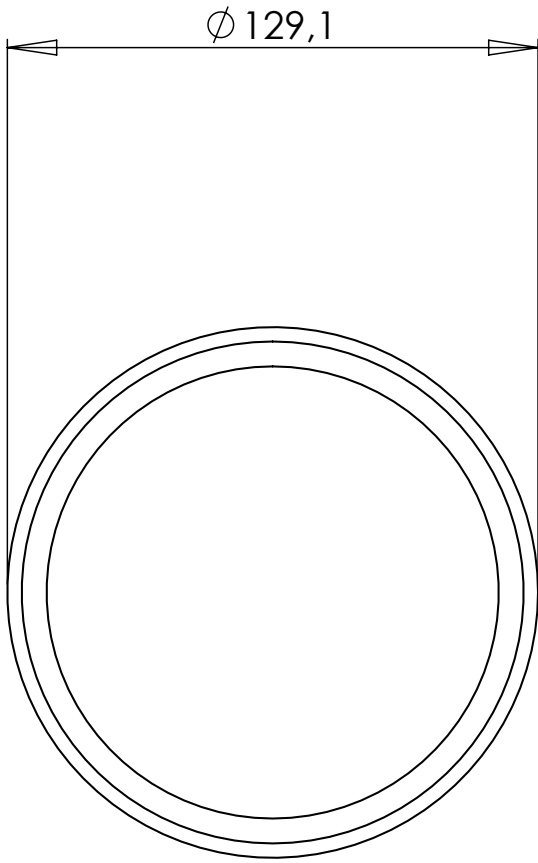

DÉTAIL B

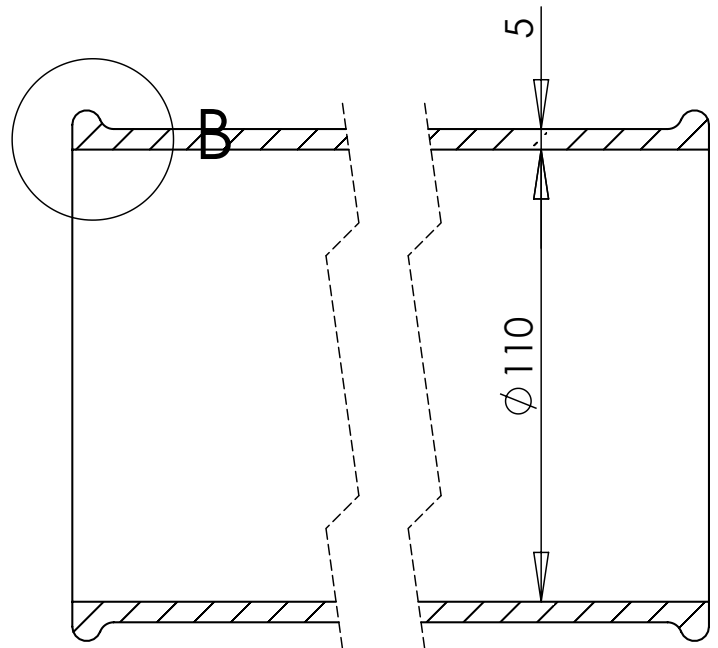

COUPE A-A