

Qty	Piece	Finishing			
1	TRIPOD	MAT BLACK	1	COVER CUP	MAT WHITE
1	TRIPOD FOOT	MAT BLACK	1	THREAD 10x100	
1	PIVOT WASHER	BLACK	1	BULBHOLDER	
1	PIVOT LOCK PIECE	MAT BLACK	2	M10 x 4 NUT	
1	PIVOT GUIDE	MAT BLACK	1	M4 PLASTIC SCREW	TRANSPARENT
1	WEIGHT	MAT BLACK	1	PLASTIC TUBE	
1	TUBE LOCK PIECE	MAT BLACK			
1	BAR	MAT BLACK			
1	CORD GRIPP 2	NICKELED N8			
1	TUBE	MAT BLACK			
1	CORD GRIPP	MAT BLACK			
1	BALL JOINT	NICKELED N8			
1	SHADE	MAT BLACK OUTSIDE / MAT WHITE INSIDE			
1	JUNCTION PIECE	MAT WHITE			

dcw.

Name : **BS1 – BL**

Matériaux :

Part : **Finishings**

Date :

Rev : 2

Details : E14 - ESL 11W



Qty	Piece	Finishing			
1	TRIPOD	MAT PAINTING - PANTONE 5635U	1	COVER CUP	MAT WHITE
1	TRIPOD FOOT	MAT PAINTING - PANTONE 5635U	1	THREAD 10x100	
1	PIVOT WASHER	BLACK	1	BULBHOLDER	
1	PIVOT LOCK PIECE	MAT PAINTING - PANTONE 5635U	2	M10 x 4 NUT	
1	PIVOT GUIDE	MAT PAINTING - PANTONE 5635U	1	M4 PLASTIC SCREW	
1	WEIGHT	MAT PAINTING - PANTONE 5635U	1	PLASTIC TUBE	TRANSPARENT
1	TUBE LOCK PIECE	MAT PAINTING - PANTONE 5635U			
1	BAR	MAT PAINTING - PANTONE 5635U			
1	CORD GRIPP 2	NICKELED N8			
1	TUBE	MAT PAINTING - PANTONE 5635U			
1	CORD GRIPP	MAT PAINTING - PANTONE 5635U			
1	BALL JOINT	NICKELED N8			
1	SHADE	SATIN BLACK BK 11 OUTSIDE / MAT WHITE INSIDE			
1	JUNCTION PIECE	MAT WHITE			

dcw.

Name : **BS1 – GR–BL**

Matériaux :

Part : **Finishings**

Date :

Rev : 2

Details : E14 - ESL 11W

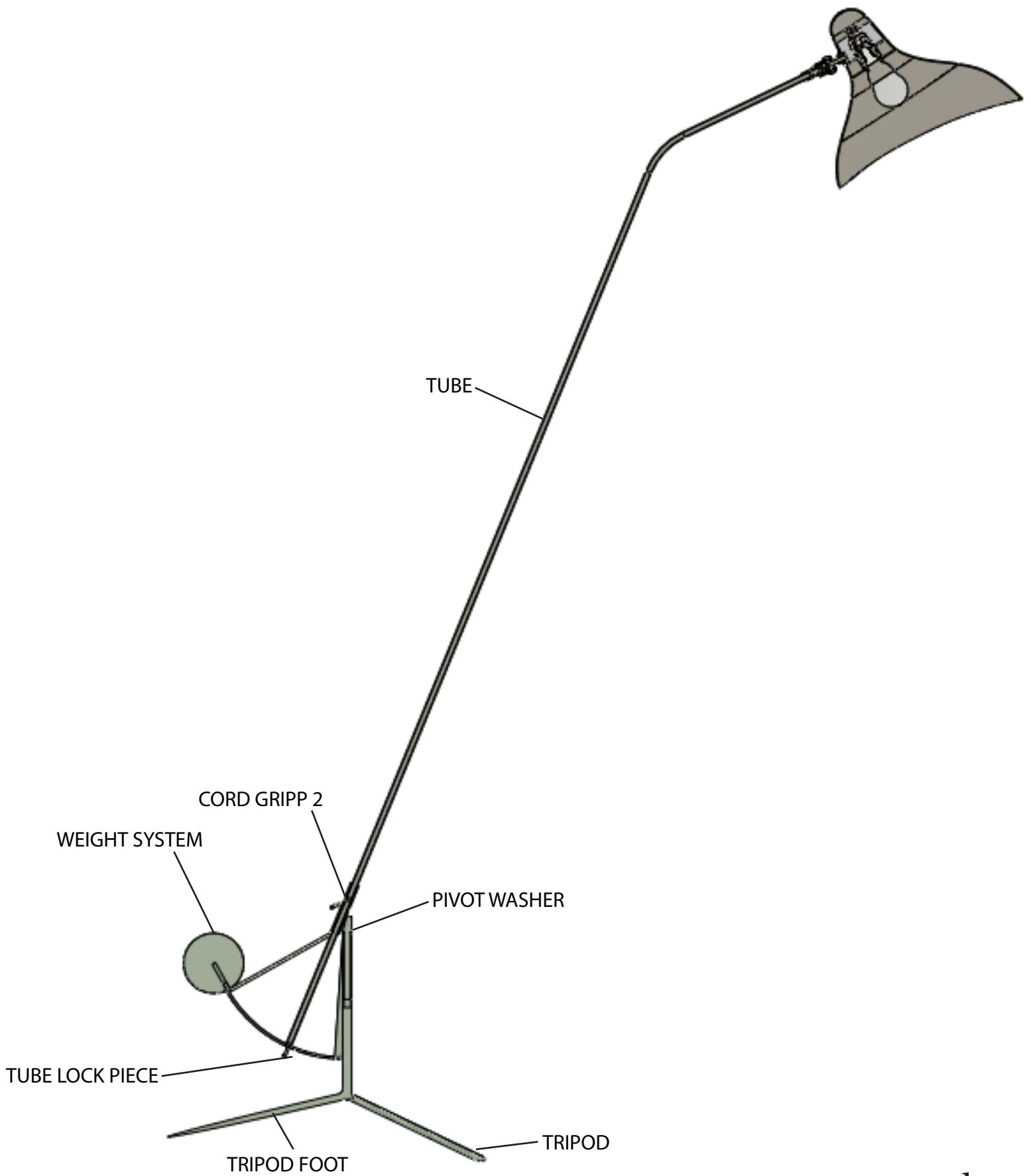

dcw.

Name : BS1 FLOOR		Matériaux :
Part : ELEMENTS		
Date :	Rev : 2	Details :

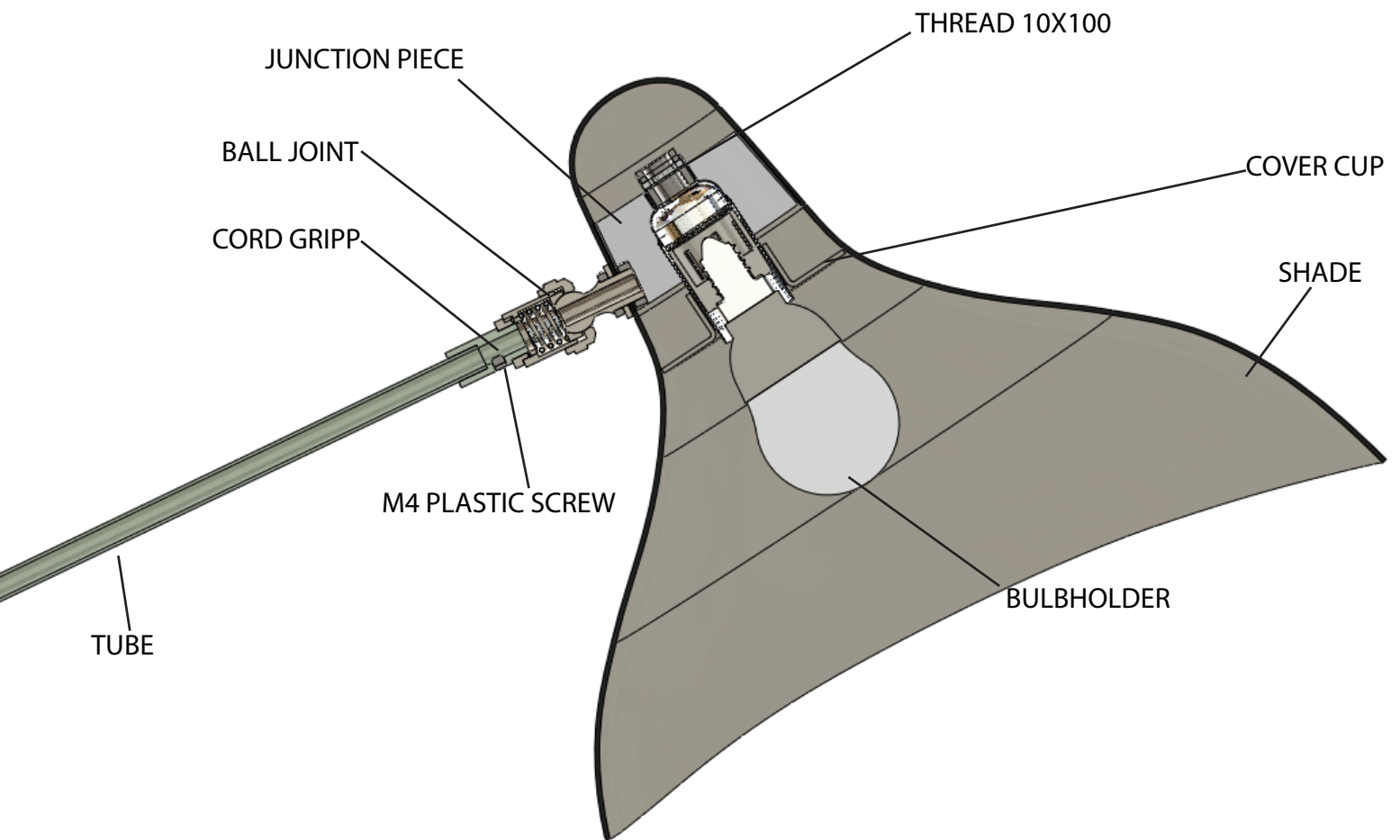



dcw.

Name : **BS1 FLOOR**

Matériaux :

Part :

Date :

Rev : 1

Details : E14 - ESL 11W

WEIGHT

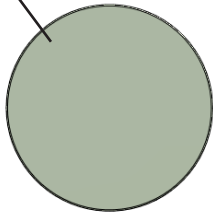

PIVOT GUIDE

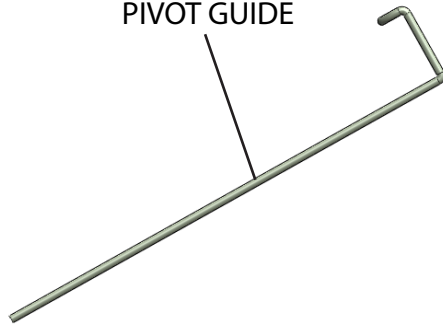

PIVOT LOCK PIECE

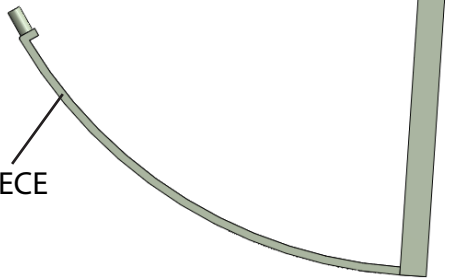

PIVOT

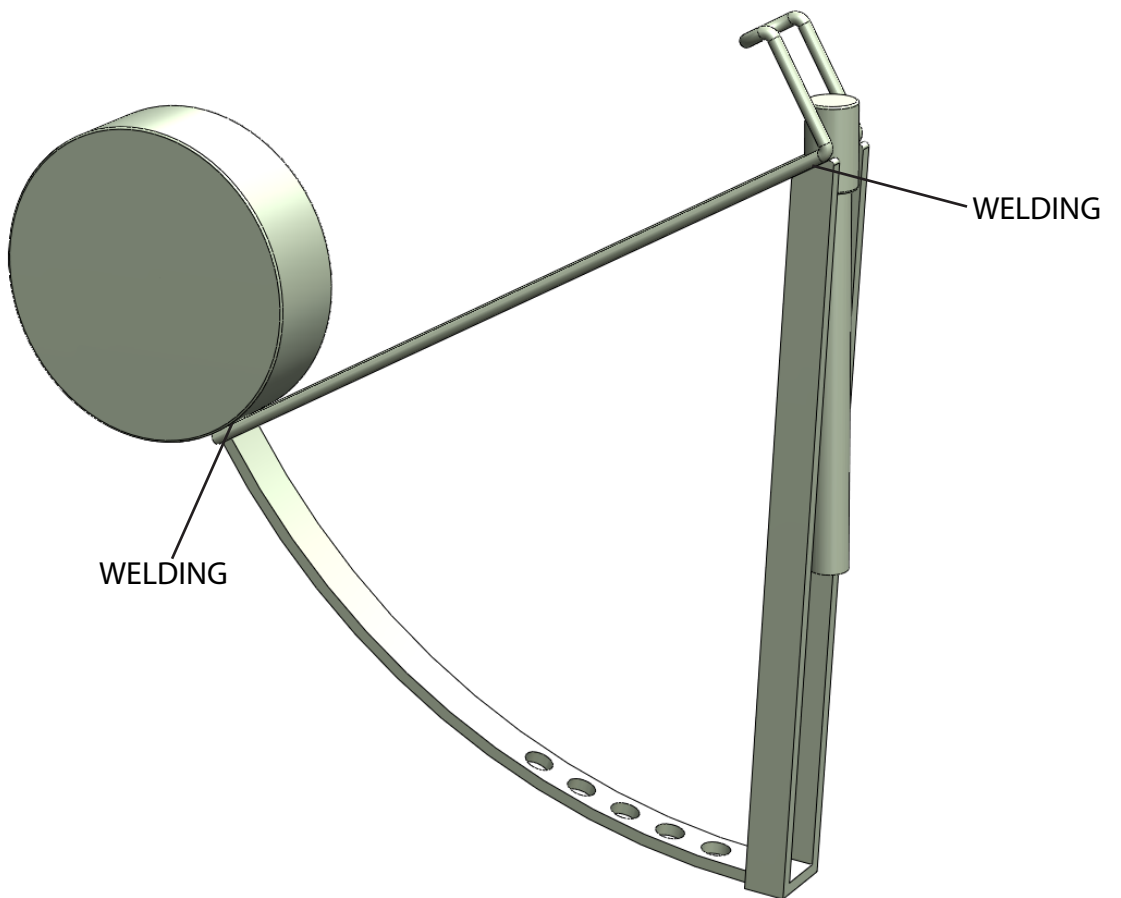

dcw.

Name : BS1 FLOOR & BS3 TABLE

Materials :

Part : WEIGHT SYSTEM DETAILS

Date :

Rev : 1

Details :

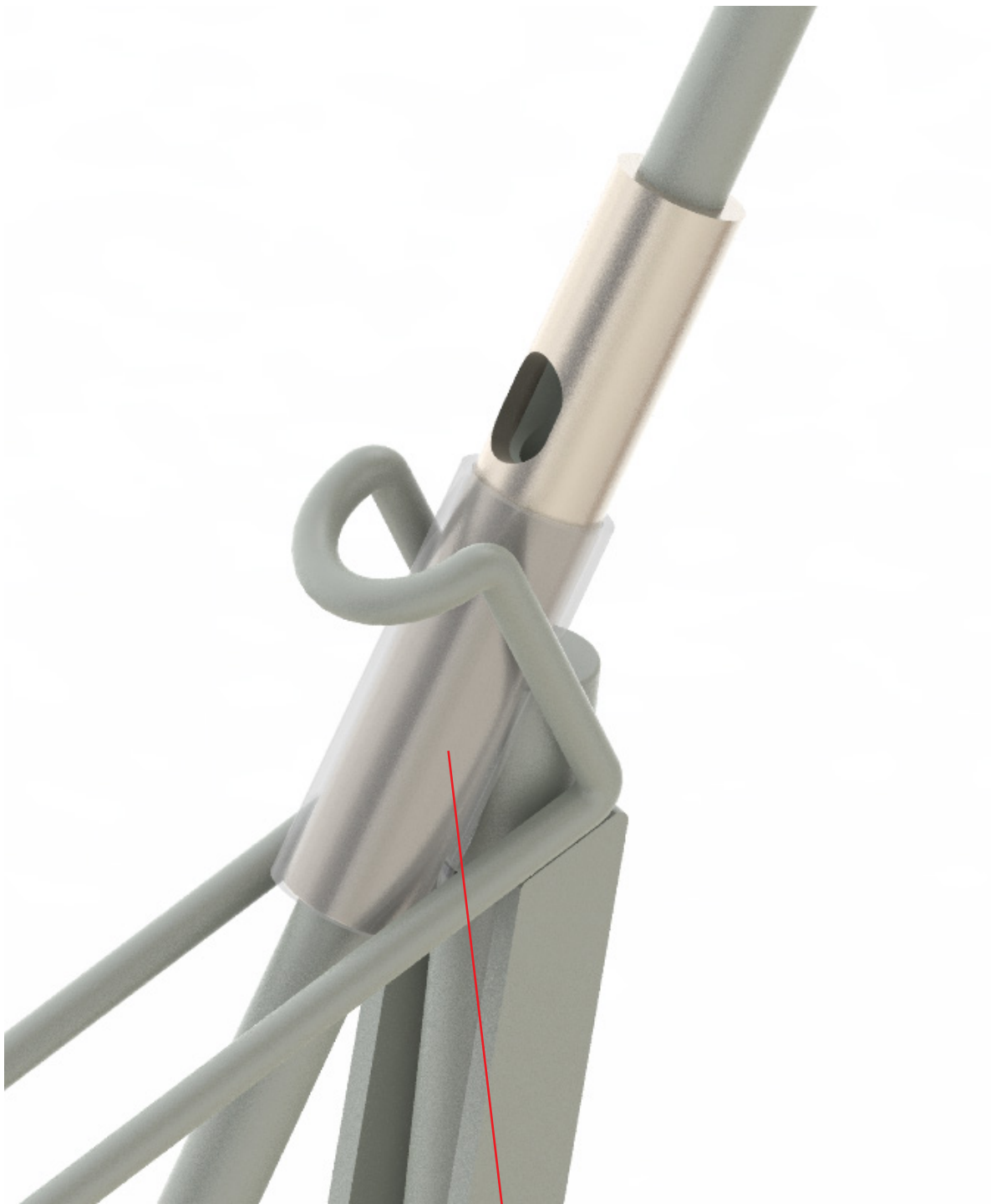

Plastic tube to protect painting

dcw.

Name : **BS1 FLOOR & BS3 TABLE**

Materials :

Part :

Date :

Rev : 1

Details : E14 - ESL 11W

Actual Sample

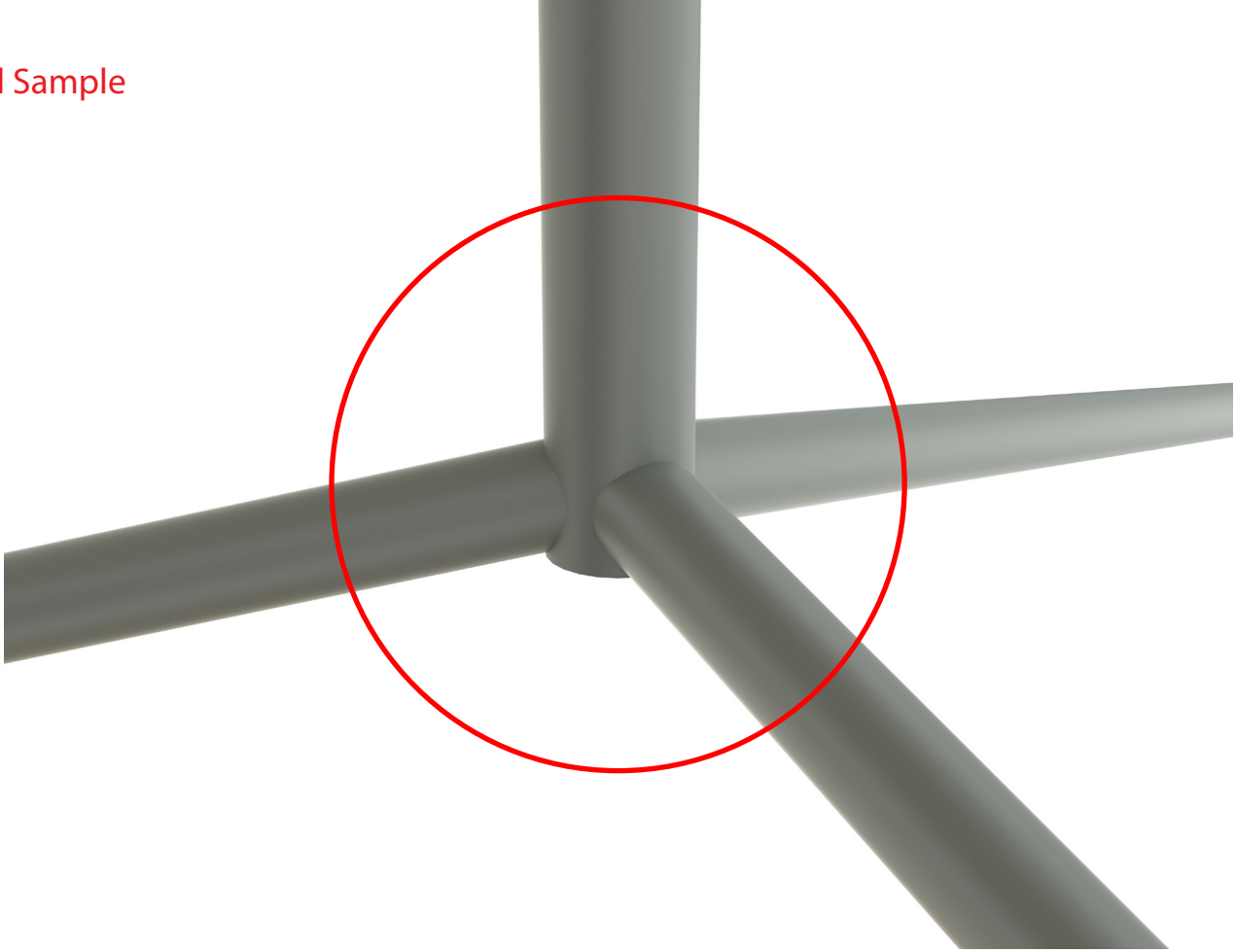

What we want

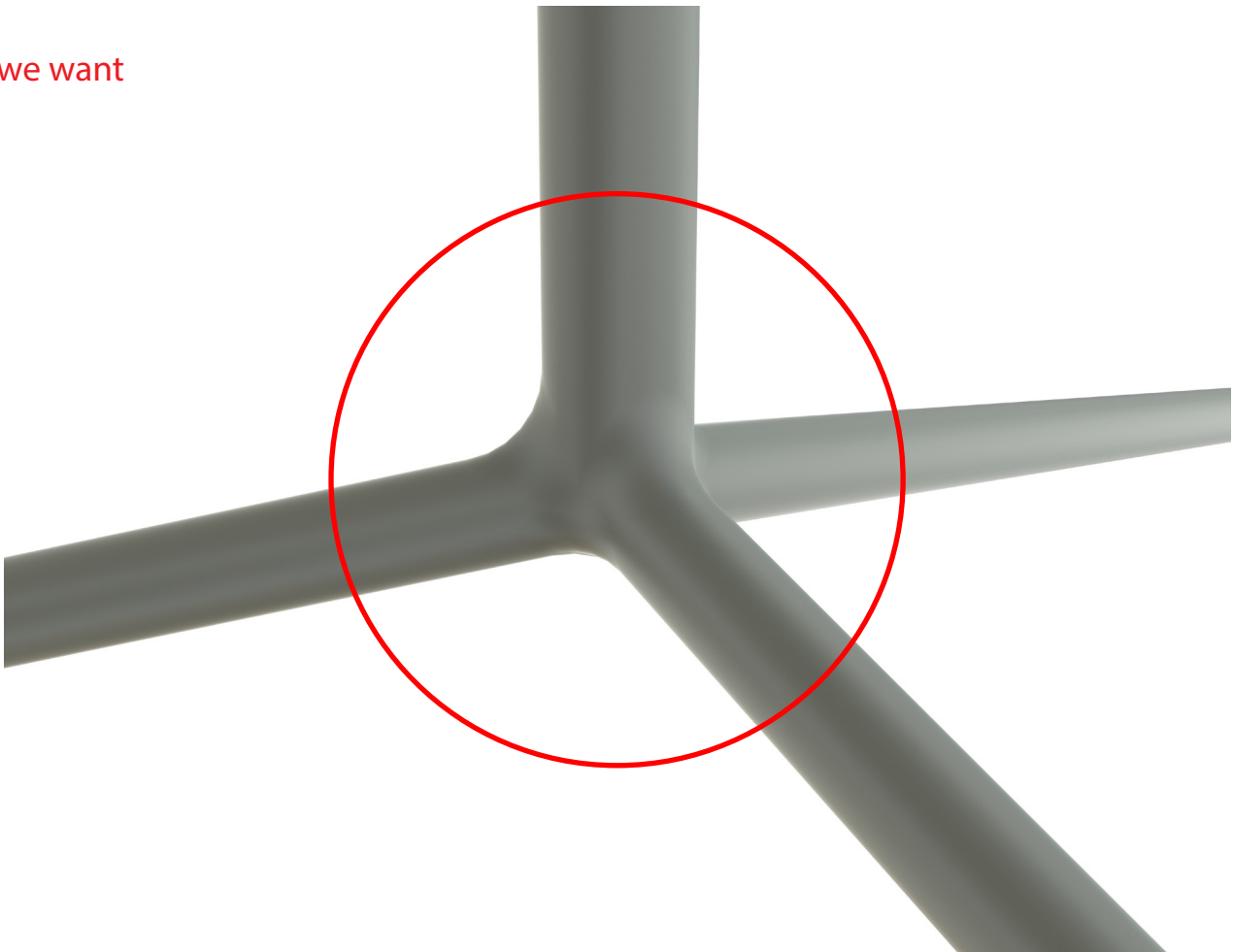

dcw.

Name : **BS1 FLOOR**

Materials : PAINTED STEEL

Part : **TRIPOD**

Date :

Rev : 2

Details :

Date :

Part : TRIPOD

Name : BS1 FLOOR

Rev : 3

Details :

Materials : PAINTED STEEL

dcw.

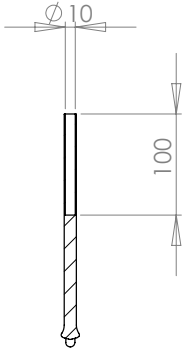

COUPE A-A

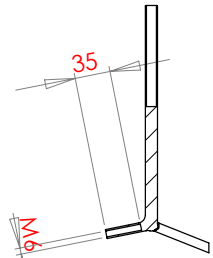
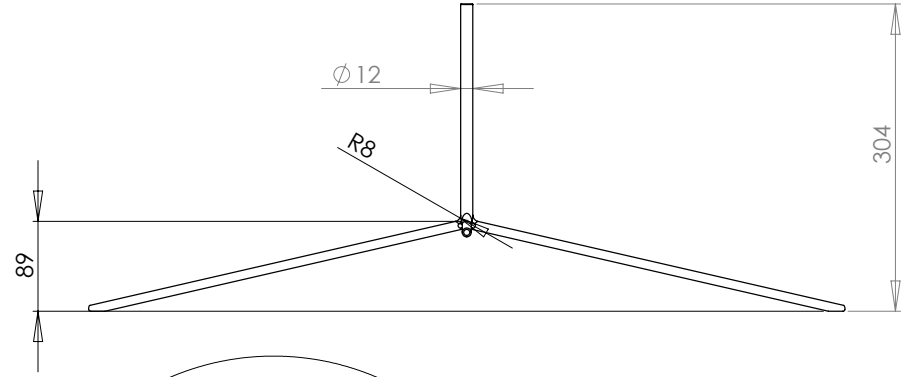
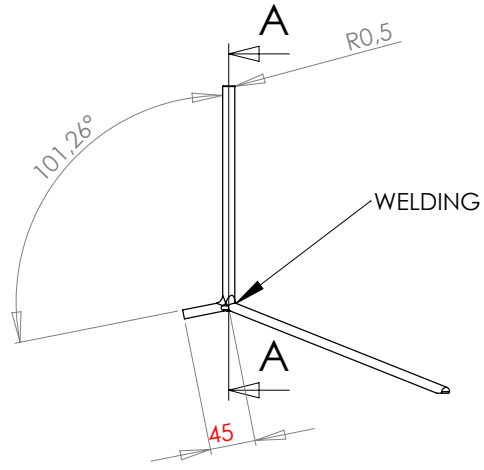

COUPE B-B

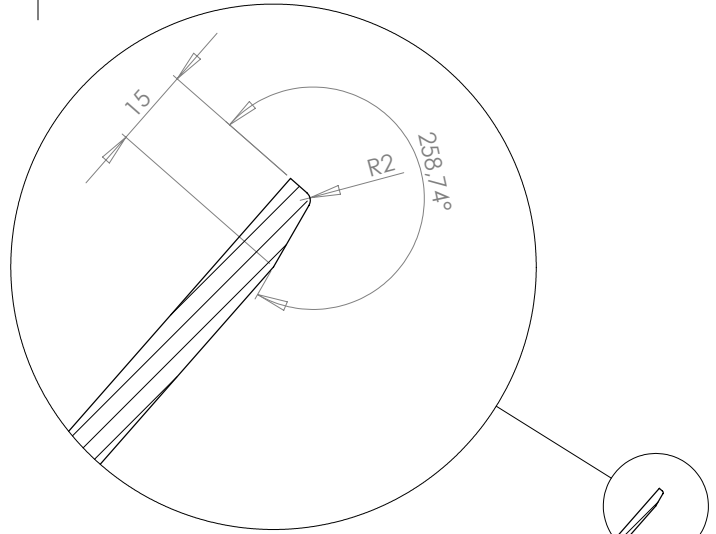
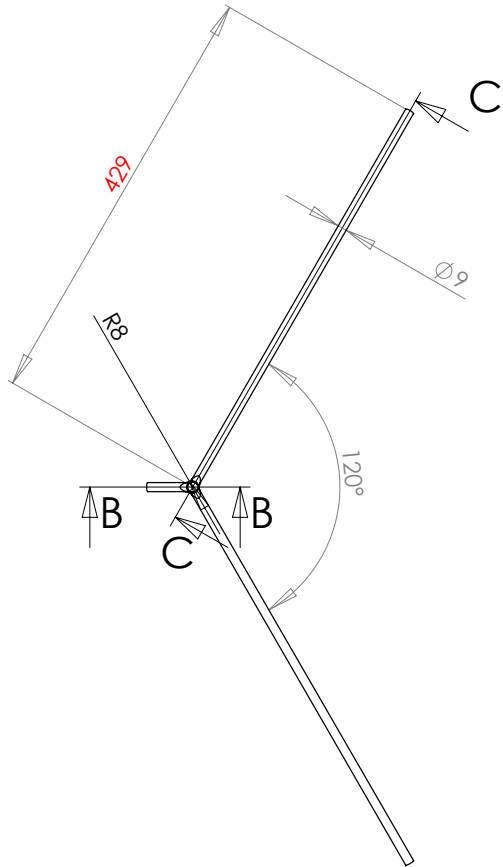

DÉTAIL I

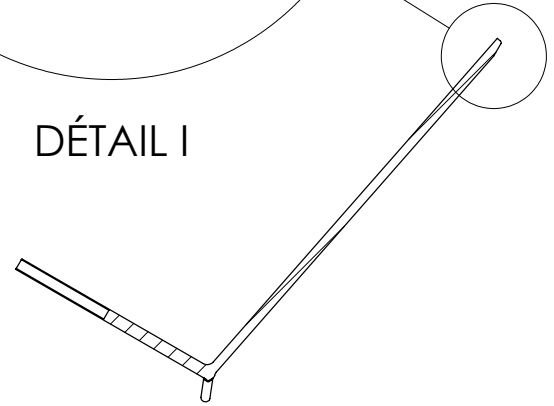

COUPE C-C

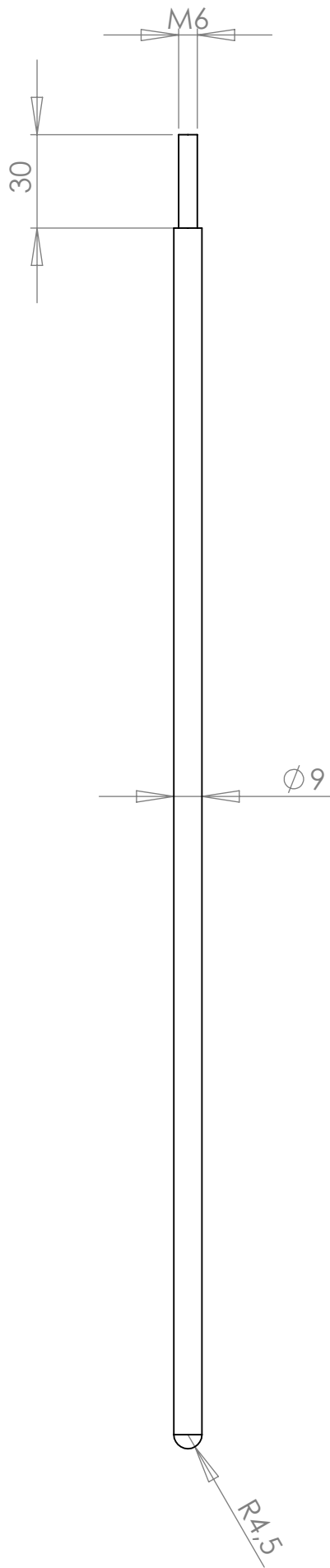

dcw.

Name : **BS1 FLOOR**

Materials : PAINTED STEEL

Part : **TRIPOD FOOT**

Date :

Rev : **1**

Details :

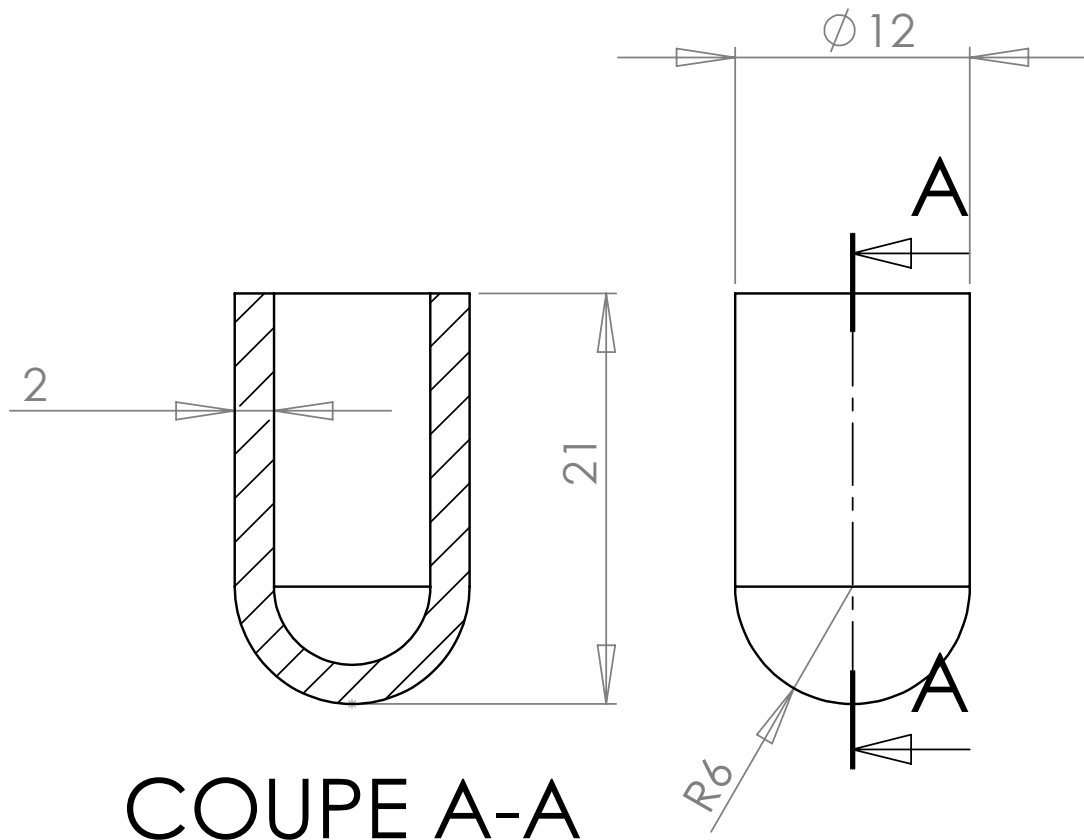

COUPE A-A

THIS PIECE WILL BE PACKED SEPARATELY

dcw.

Name : **BS1 FLOOR**

Materials : **BLACK PLASTIC**

Part : **FOOT CAP**

Date :

Rev : **1**

Details :

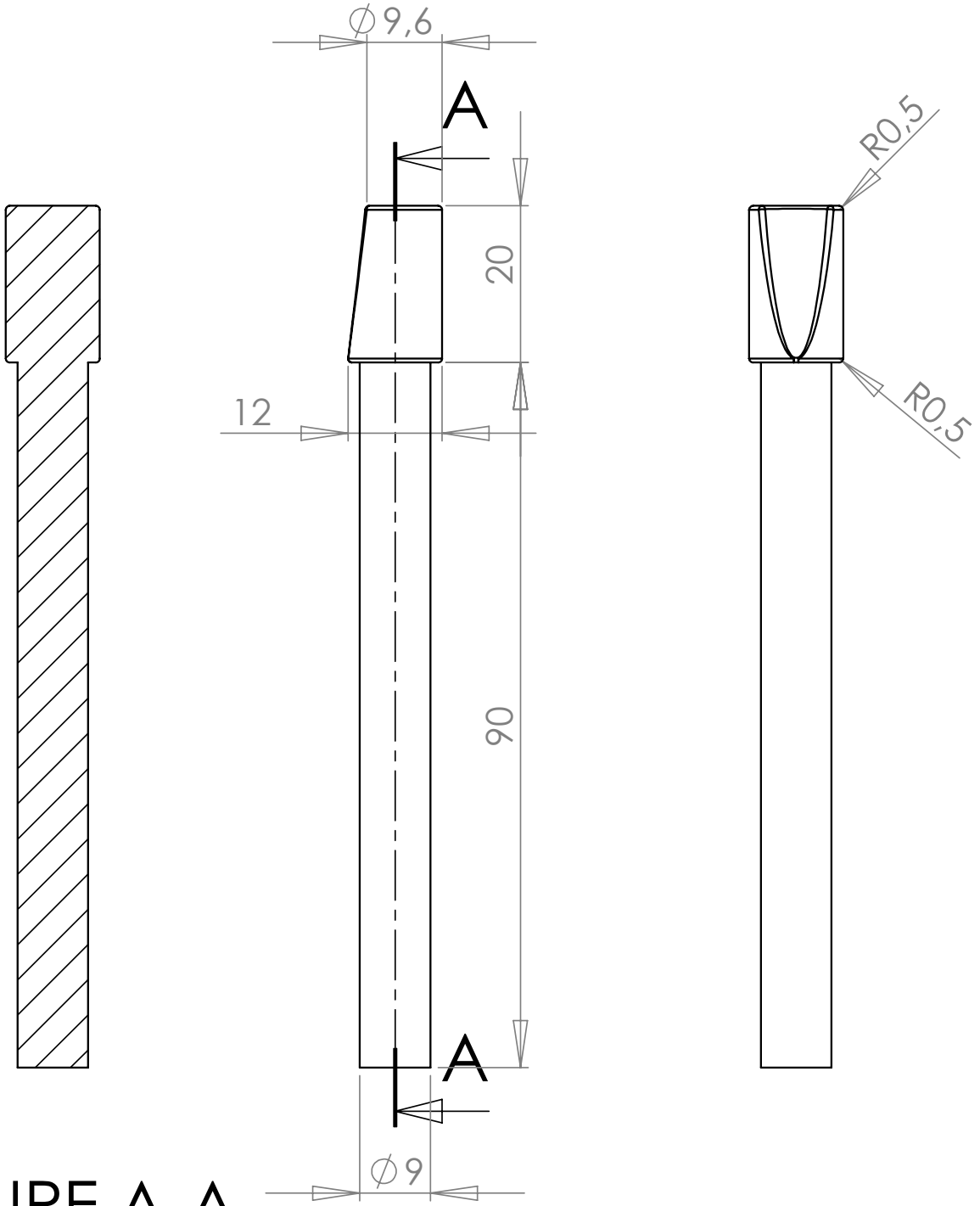

COUPE A-A

dcw.

Name : BS1 FLOOR & BS3 TABLE

Materials : PAINTED STEEL

Part : PIVOT

Date :

Rev : 2

Details :

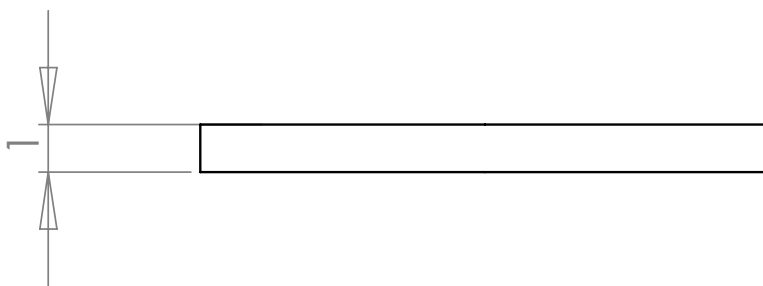
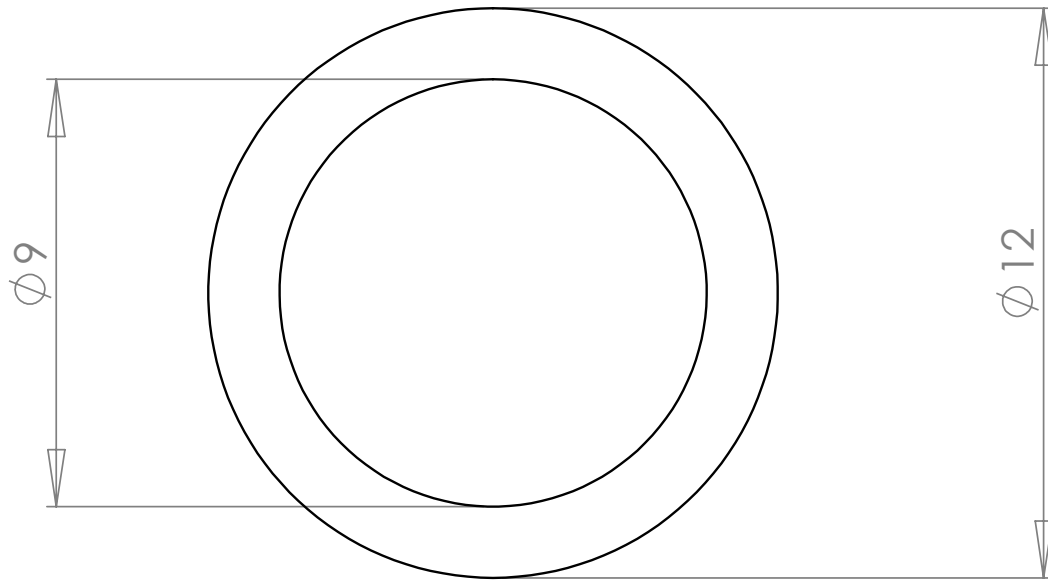

dcw.

Name : **BS1 FLOOR & BS3 TABLE**

Matériaux : PLASTIC

Part : **PIVOT WASHER**

Date :

Rev : 1

Details :

Name : **BS1 FLOOR**
Part : **PIVOT GUIDE**
Date :

Rev : **3**

Materials : **PAINTED STEEL**
Details :

dcw.

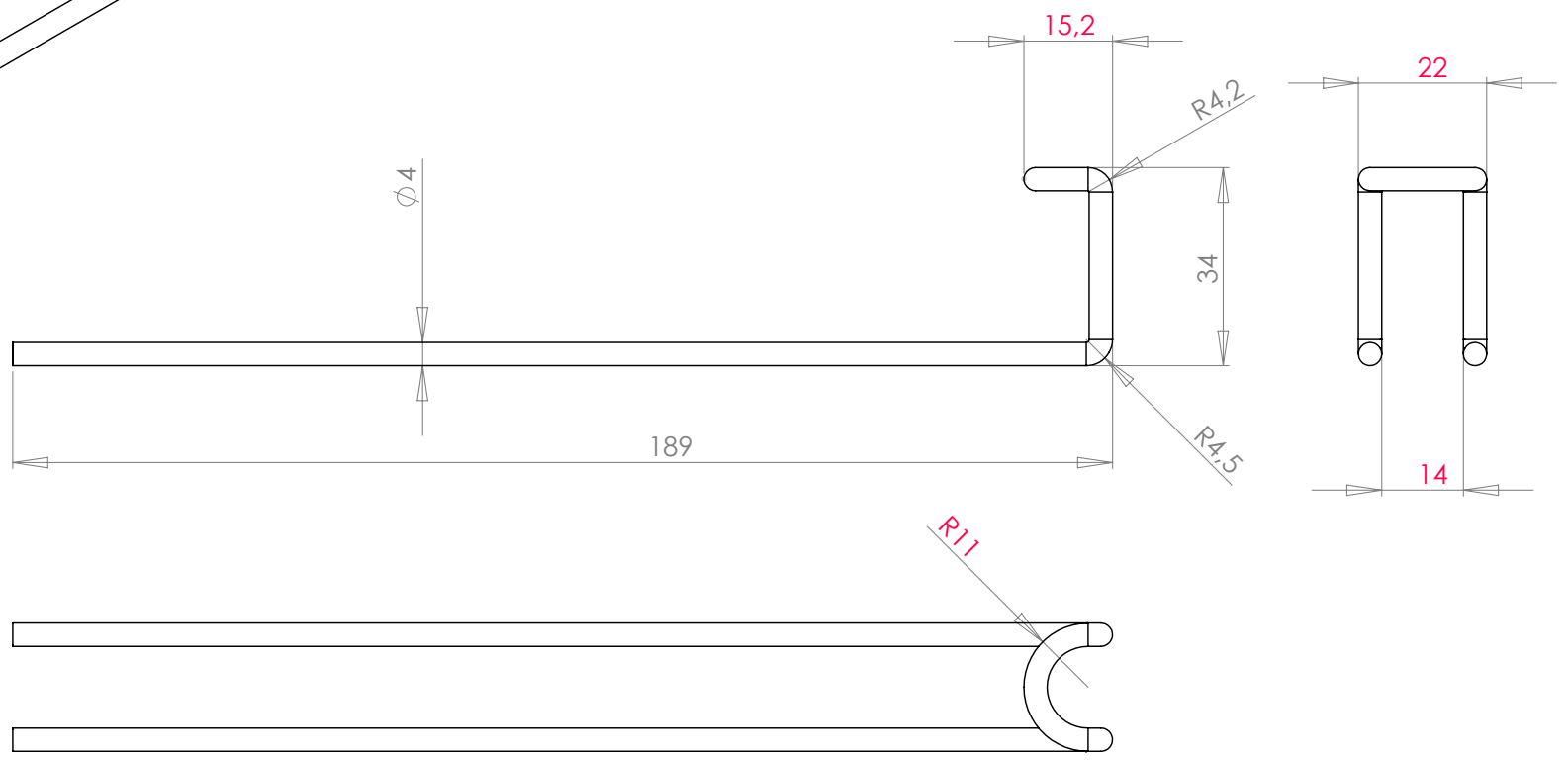
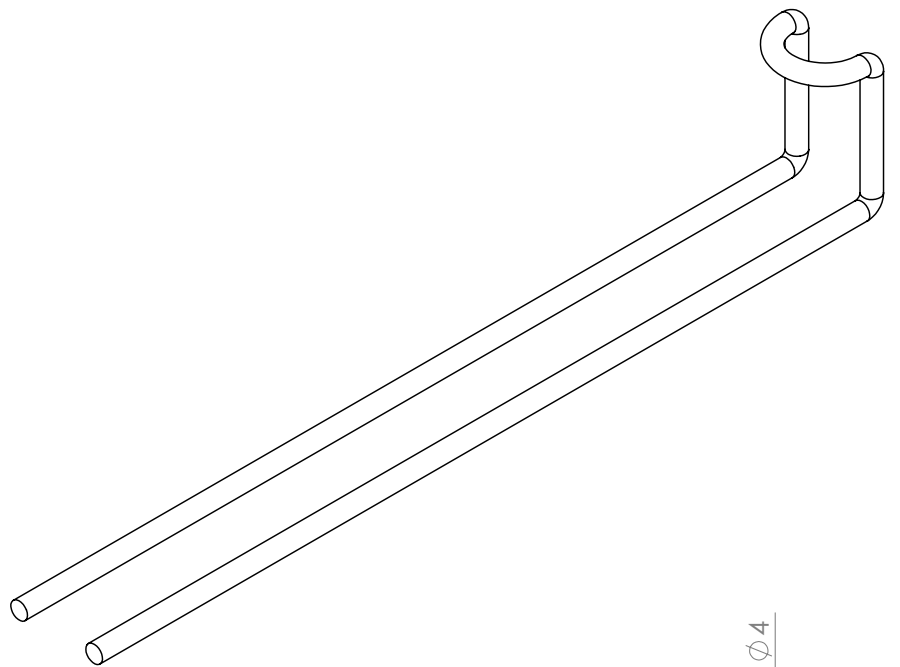

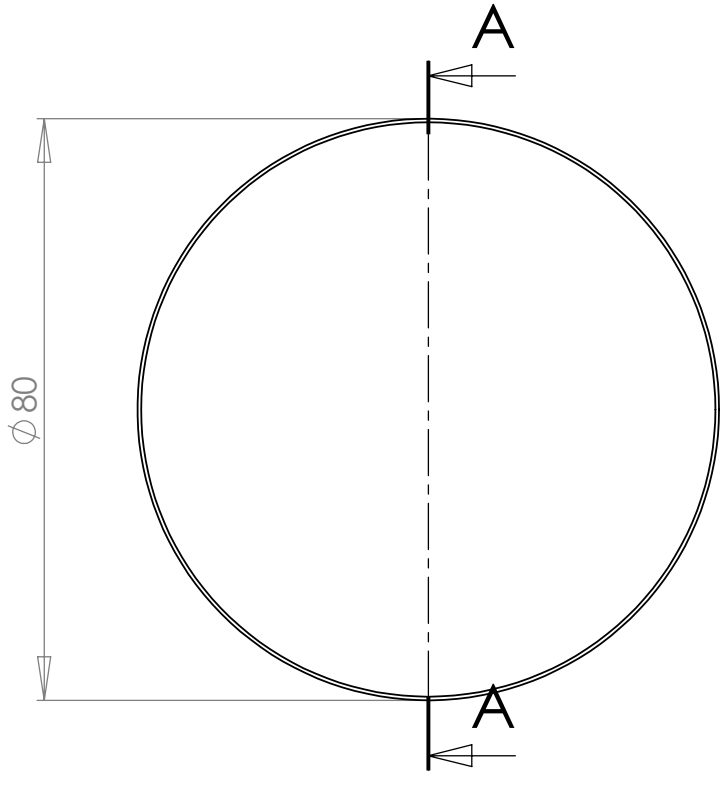
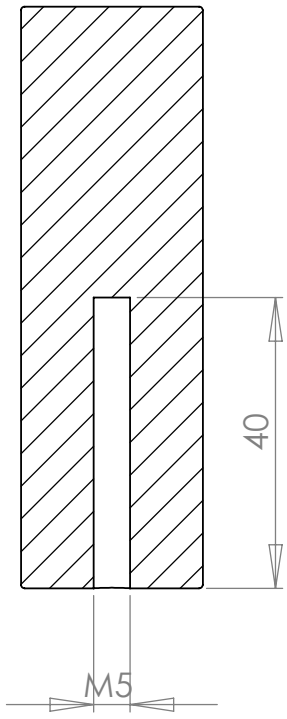
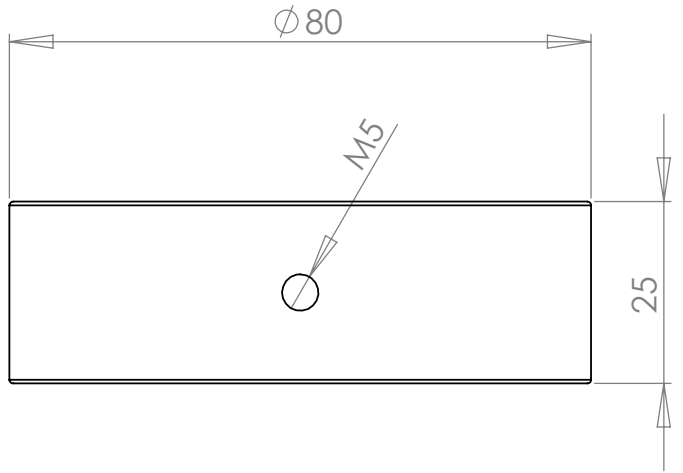

COUPE A-A

dcw.

Name : **BS1 FLOOR** Materials : PAINTED STEEL

Part : **WEIGHT**

Date :

Rev : **4**

Details :

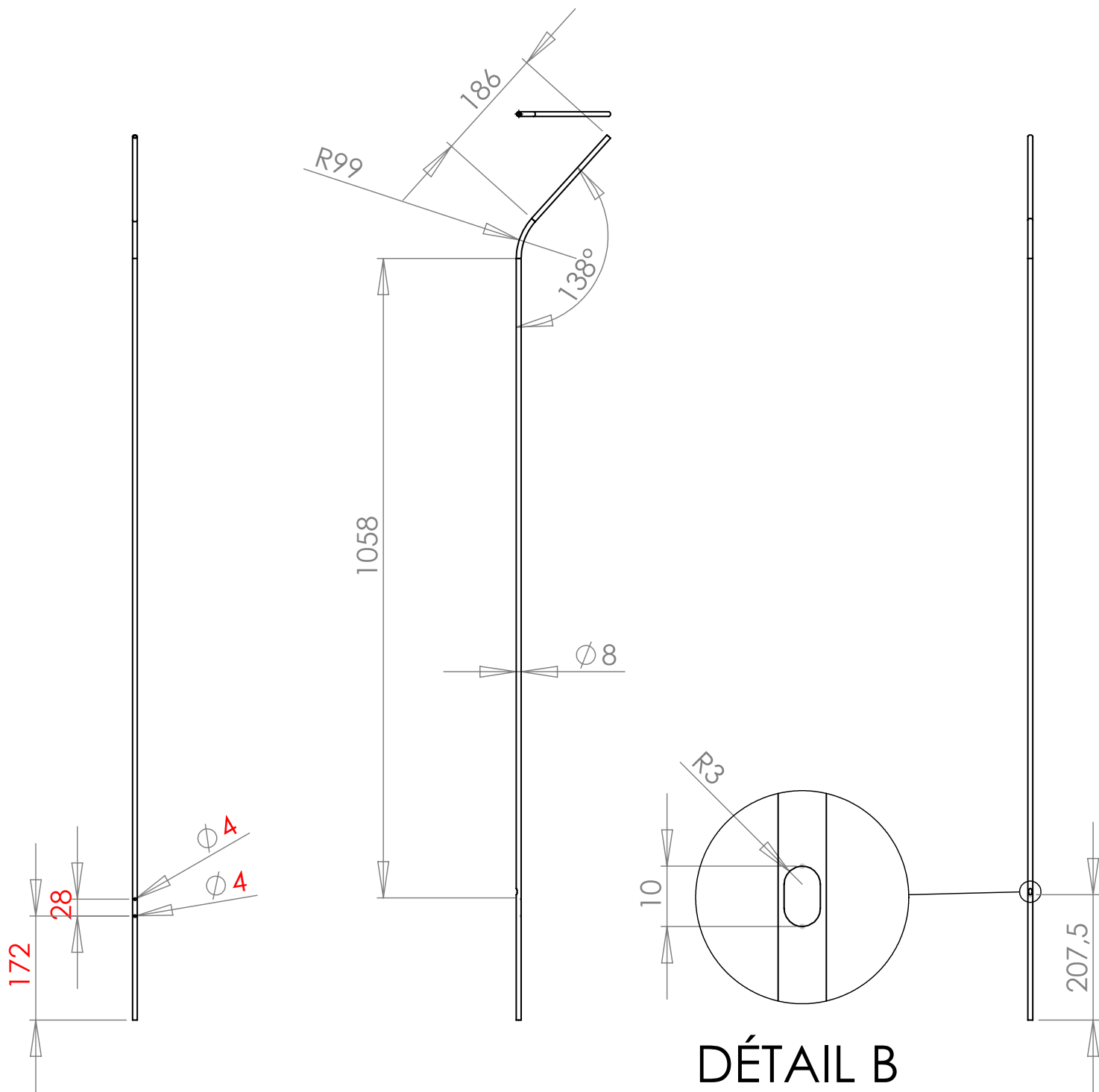

dcw.

Name : **BS1 FLOOR**

Part : **TUBE**

Date :

Rev : **4**

Matériaux : PAINTED STEEL - 15CDV6 or 25CD4S

Details :

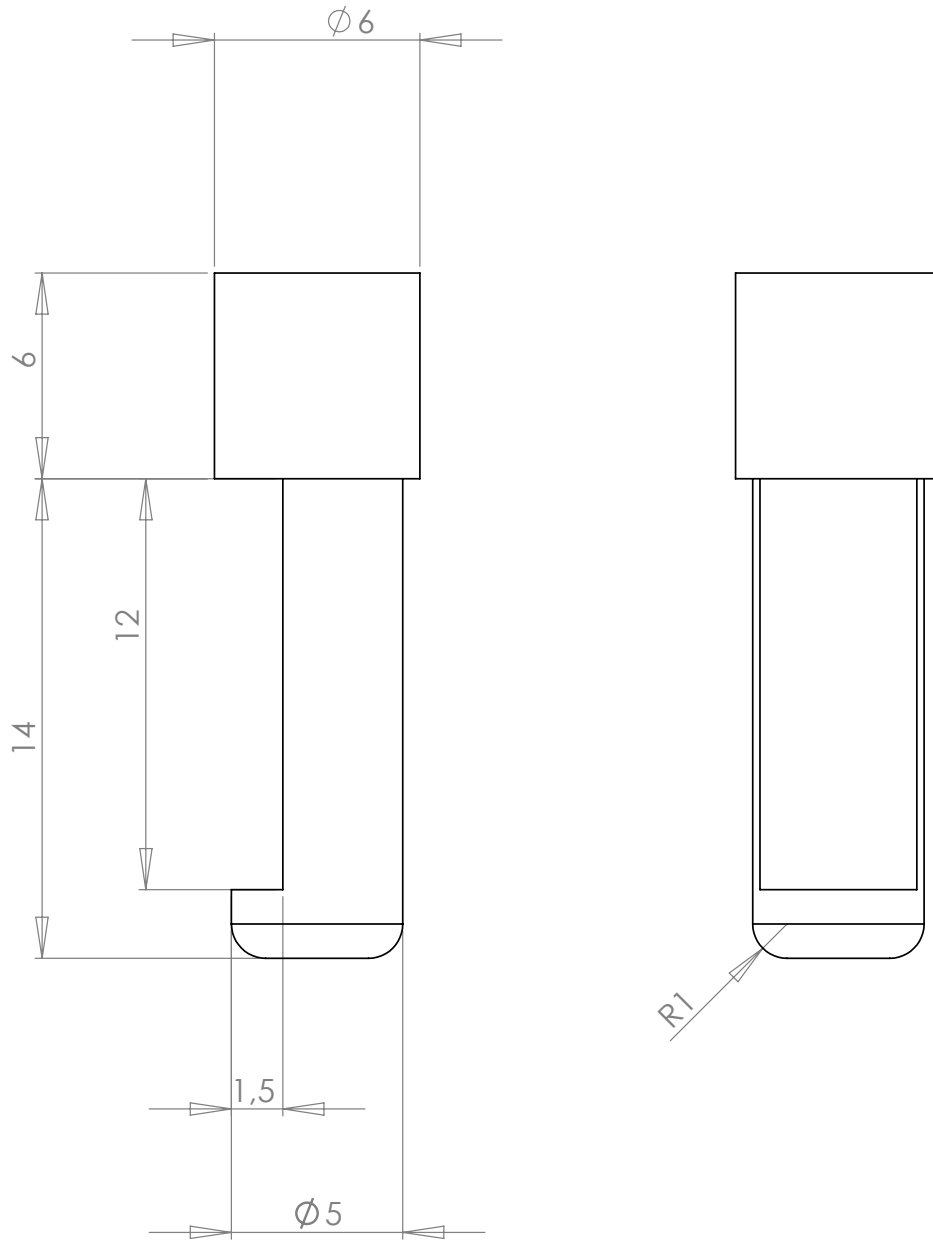

dcw.

Name : **BS1 FLOOR & BS3 TABLE**

Materials : PAINTED STEEL

Part : **TUBE LOCK PIECE**

Date :

Rev : 2

Details :

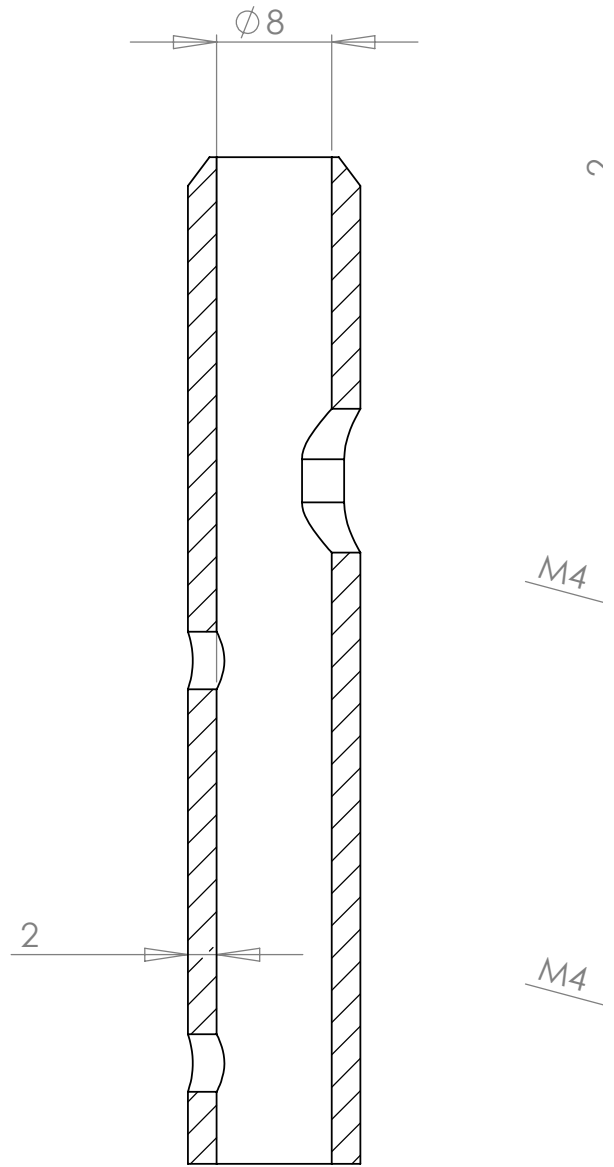
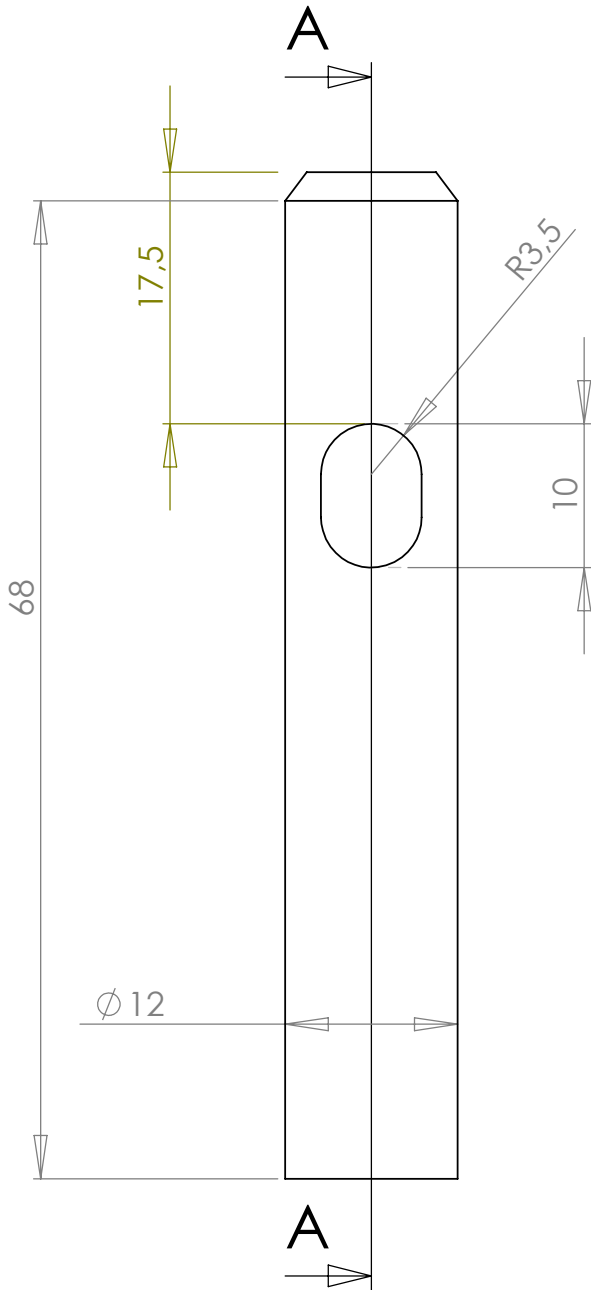
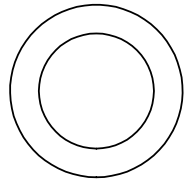

COUPE A-A

dcw.

Name : BS1 FLOOR & BS3 TABLE

Matériaux : NICKELÉD STEEL

Part : SLEEVE

Date :

Rev : **3**

Details :

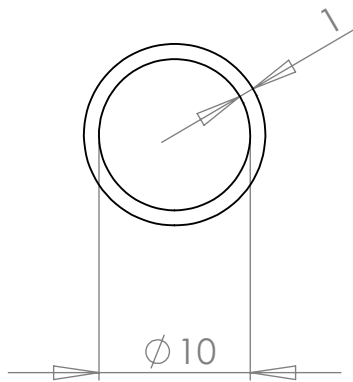
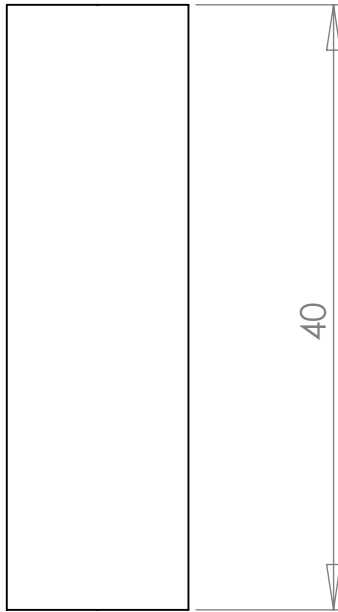

THIS PIECE WILL BE PACKED SEPARATELY

dcw.

Name : **BS1 FLOOR & BS3 TABLE**

Materials : TRANSPARENT PLASTIC

Part : **PLASTIC TUBE**

Date :

Rev : **1**

Details :

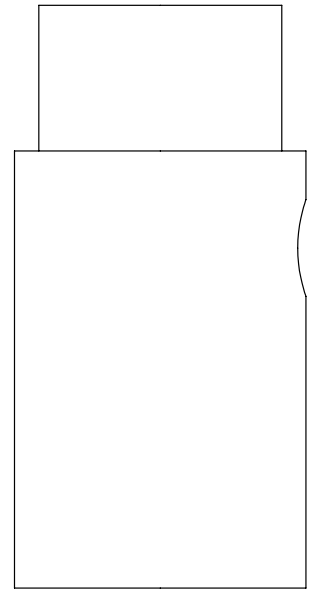
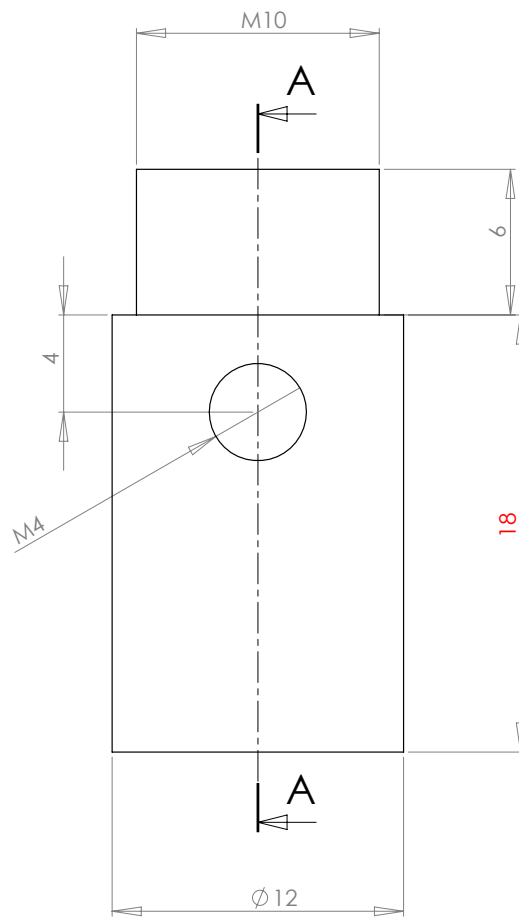
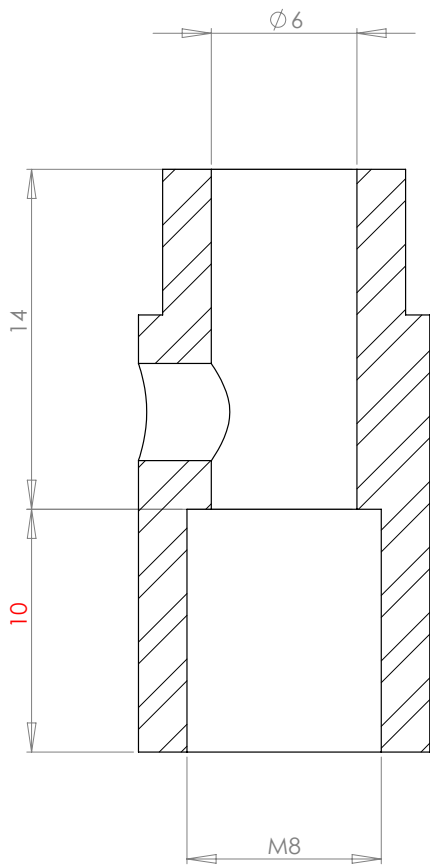

COUPE A-A

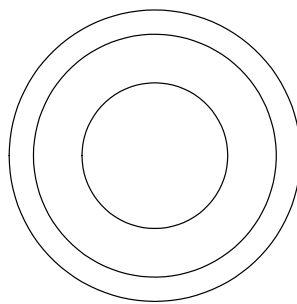

dcw.

Name : **BS RANGE**

Materials : PAINTED STEEL

Part : **CORD GRIPP**

Date :

Rev : 2

Details :



BALL JOINT WASHER



HEXAGON NUT M10x4

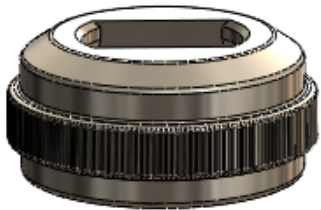

BALL JOINT PART 4



BALL JOINT PART 1

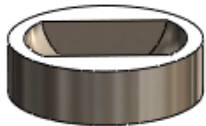

BALL JOINT PART 2

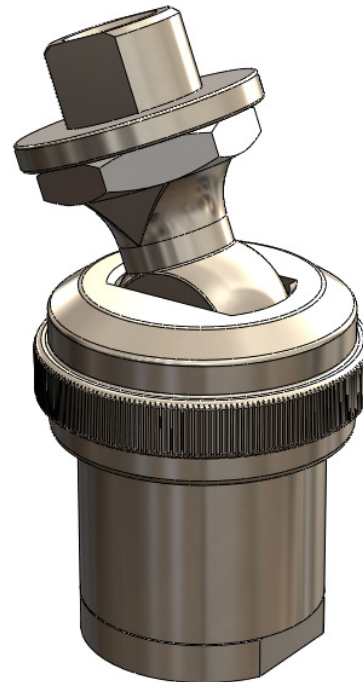

SPRING



BALL JOINT PART 3



CIRCLIP

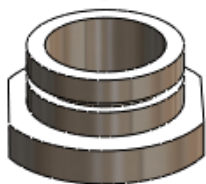

BALL JOINT PART 5

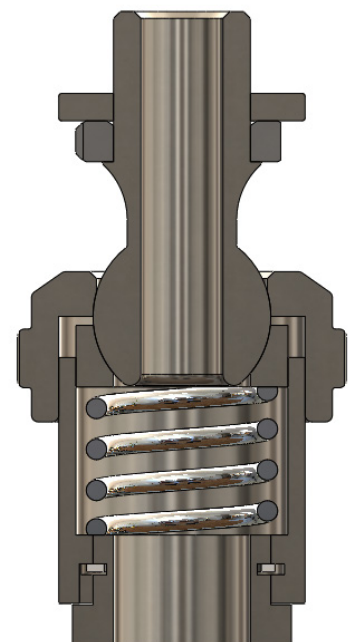
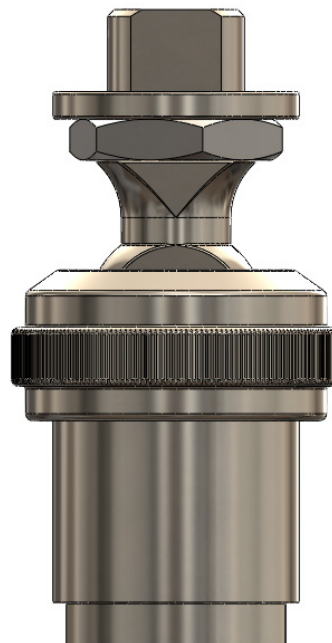

dcw.

Name : **BS RANGE**

Materials : NICKEL PLATED BRASS / PAINTED BRASS

Part : **BALL JOINT DETAILS**

Date :

Rev : **2**

Details :

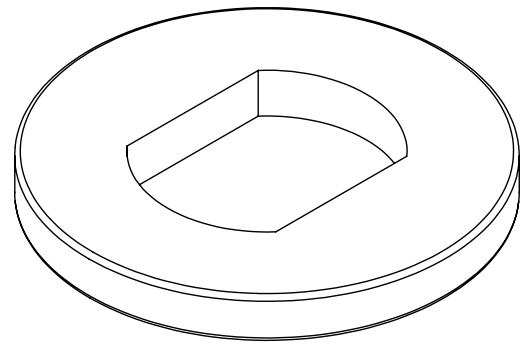
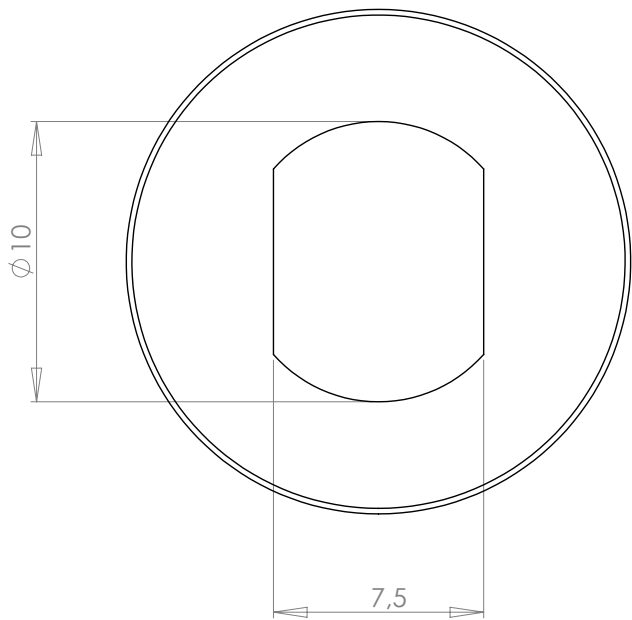
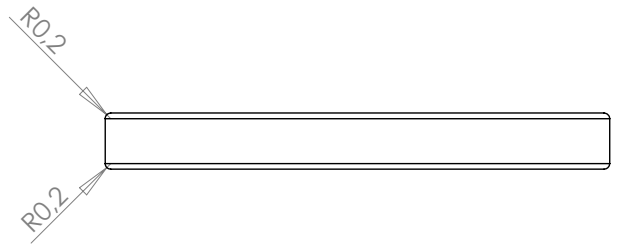
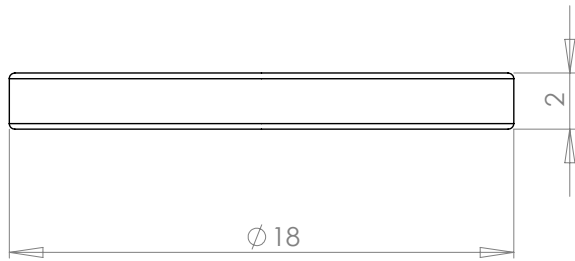
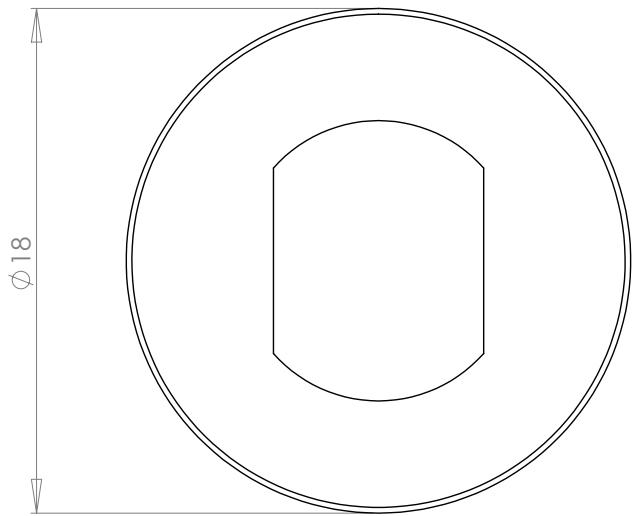

dcw.

Name : **BS RANGE**

Materials : NICKEL PLATED BRASS

Part : **BALL JOINT WASHER**

Date :

Rev : **2**

Details :

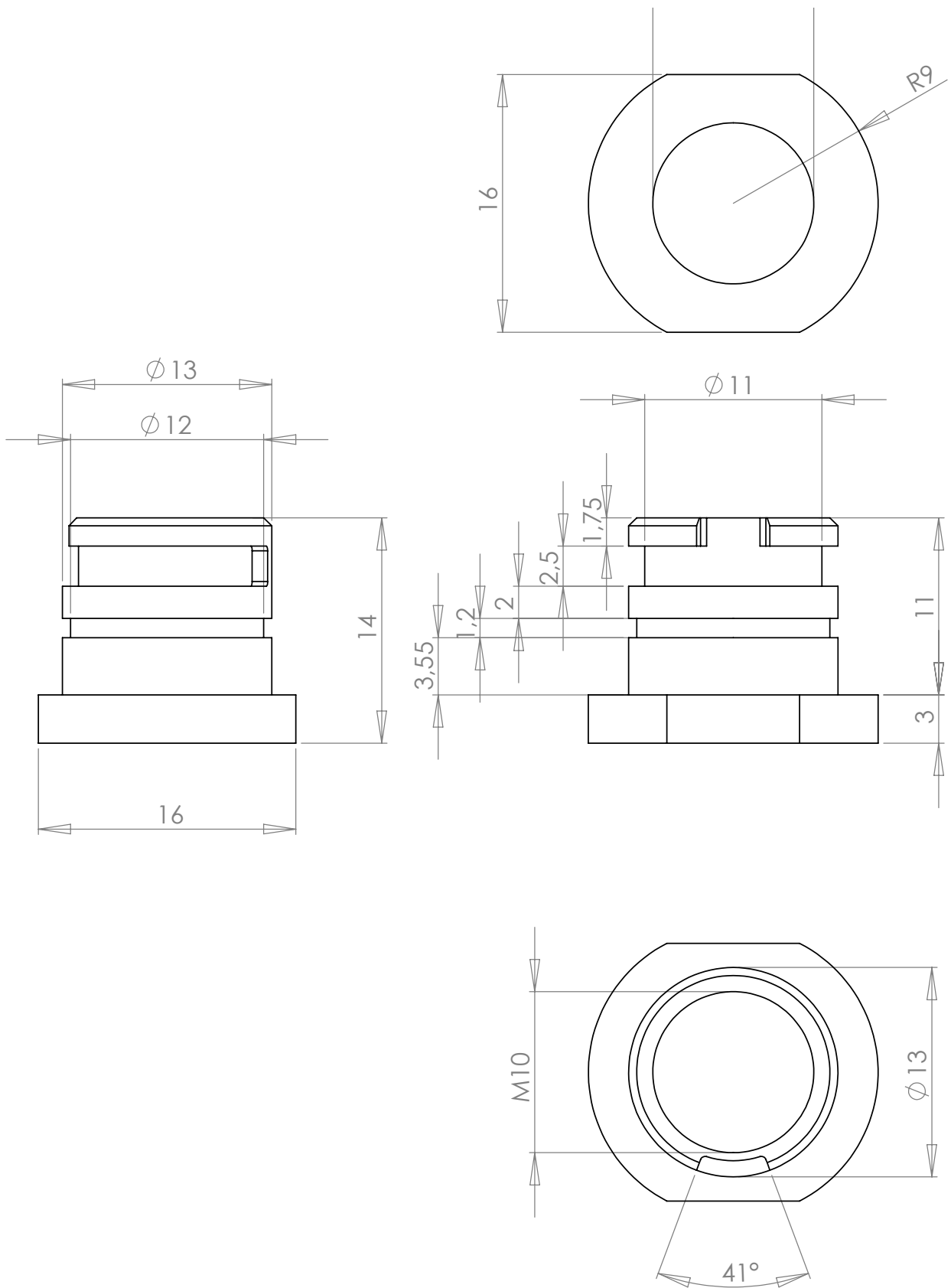

dcw.

Name : **BS RANGE**

Materials : NICKEL PLATED BRASS

Part : **BALL JOINT PART 5**

Date :

Rev : **2**

Details :

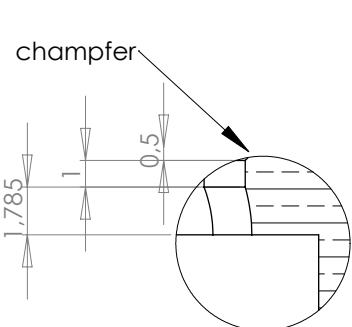

DÉTAIL B
ECHELLE 5 : 1

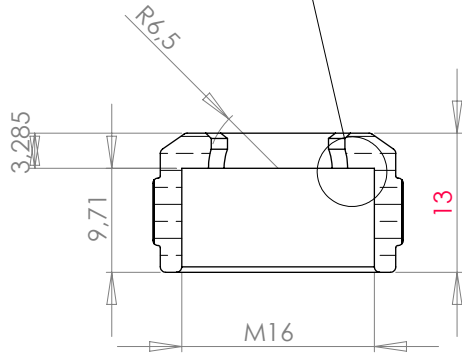

COUPE A-A

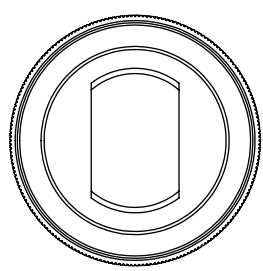
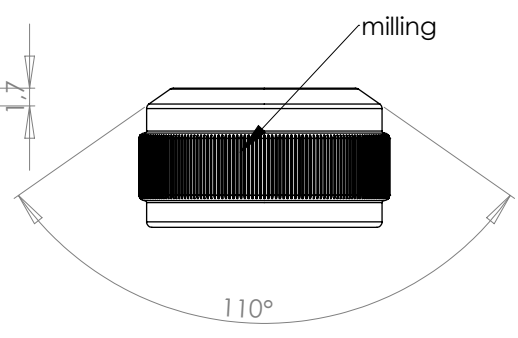
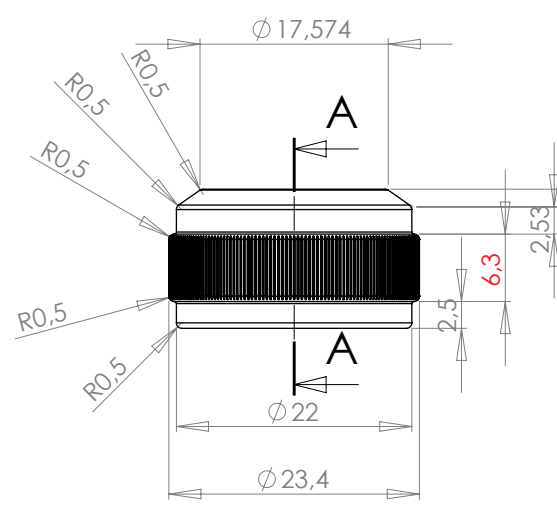
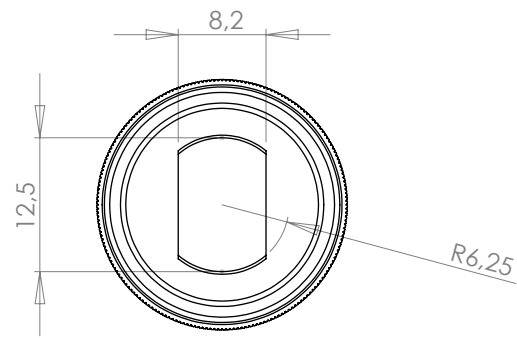

dcw.

Name : **BS RANGE**

Materials : NICKEL PLATED BRASS

Part : **BALL JOINT PART 4**

Date :

Rev : **4**

Details :

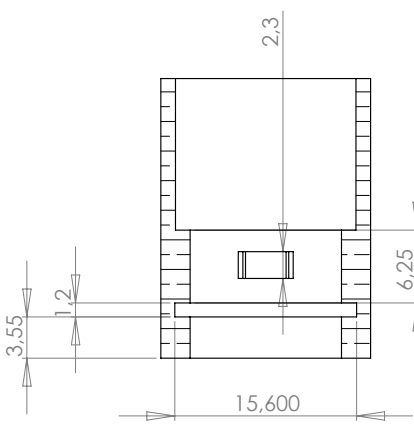
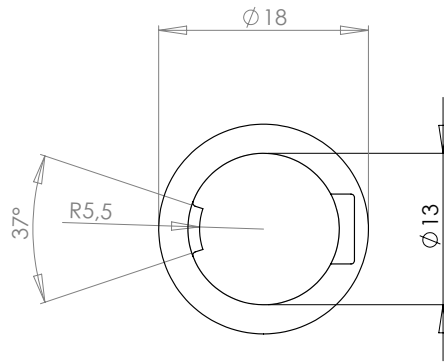

COUPE B-B

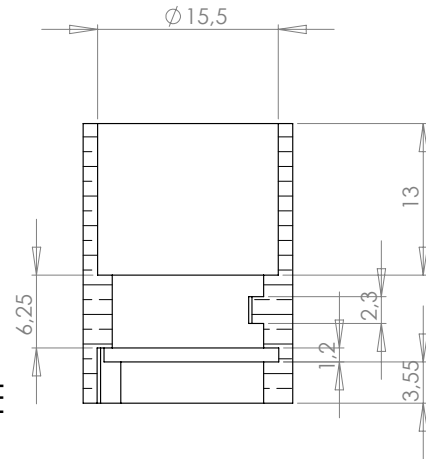
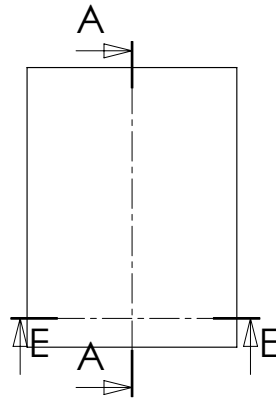
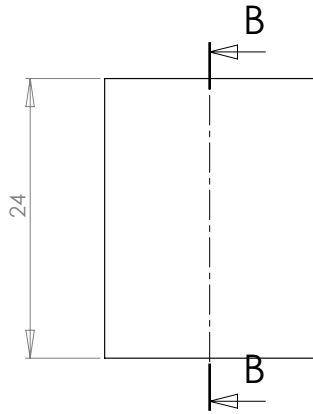

COUPE A-A

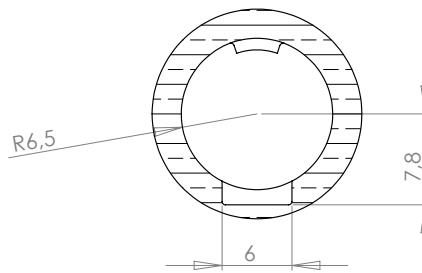

COUPE E-E

dcw.

Name : **BS RANGE**

Matériaux : NICKEL PLATED BRASS

Part : **BALL JOINT PART 3**

Date :

Rev : **3**

Details :

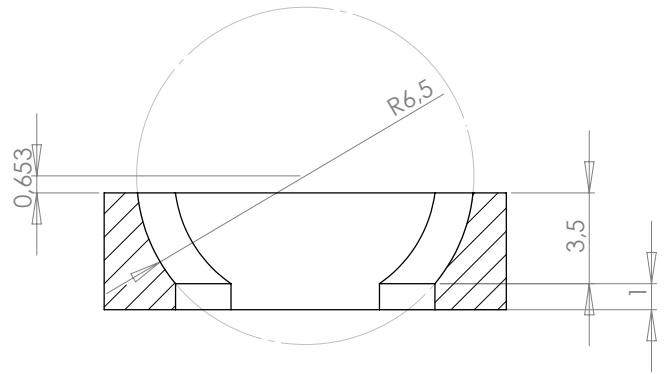
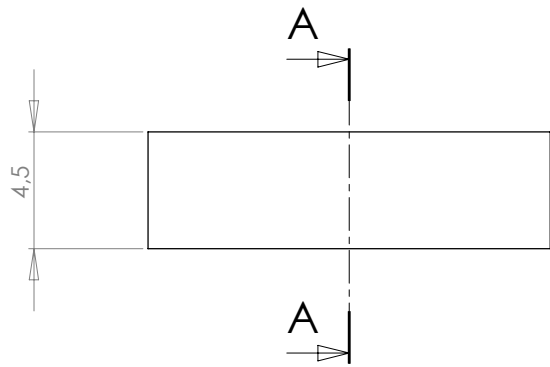
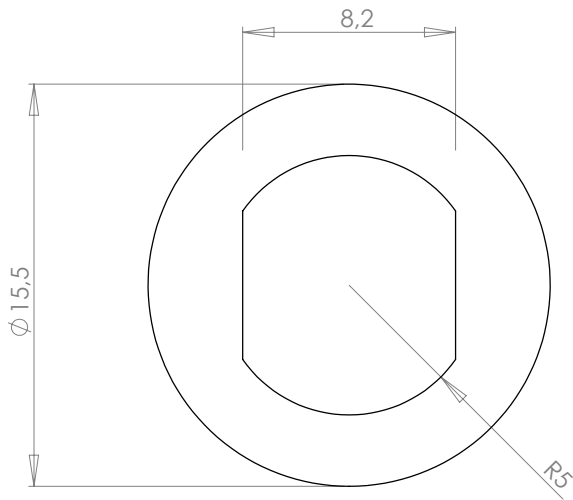

COUPE A-A

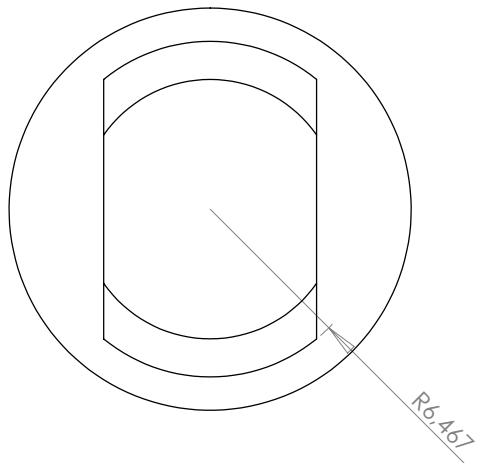

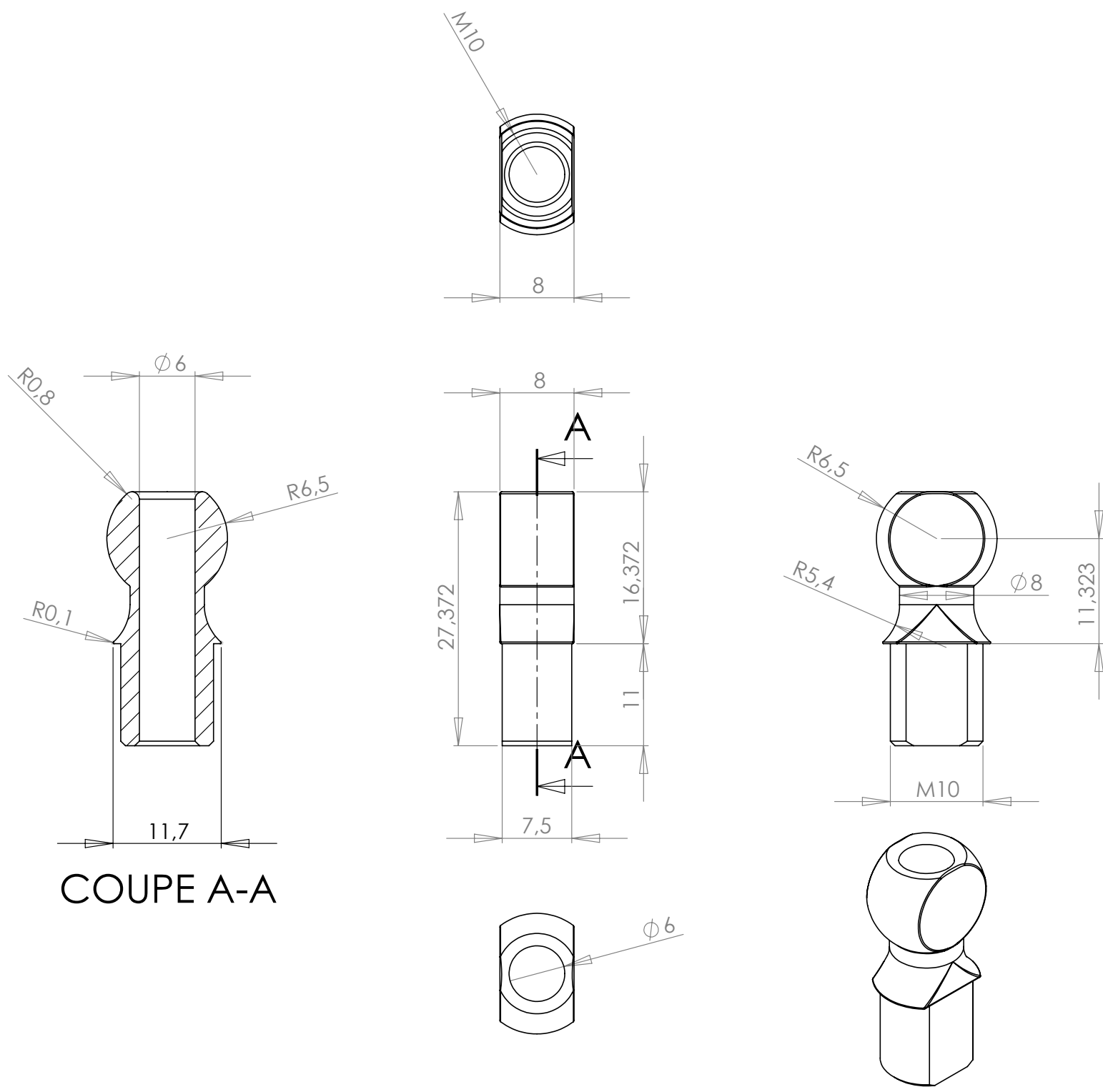

COUPE A-A

dcw.

Name : **BS RANGE**

Materials : NICKEL PLATED BRASS

Part : **BALL JOINT PART 1**

Date :

Rev : **2**

Details :

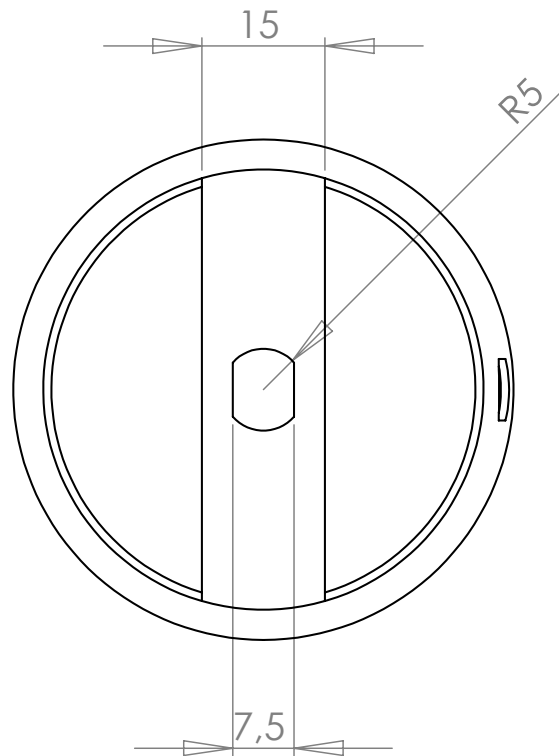
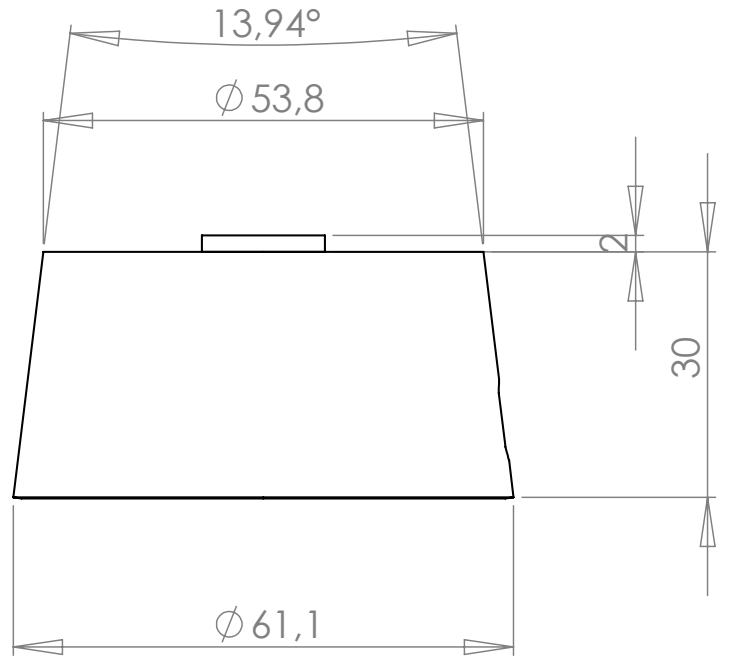
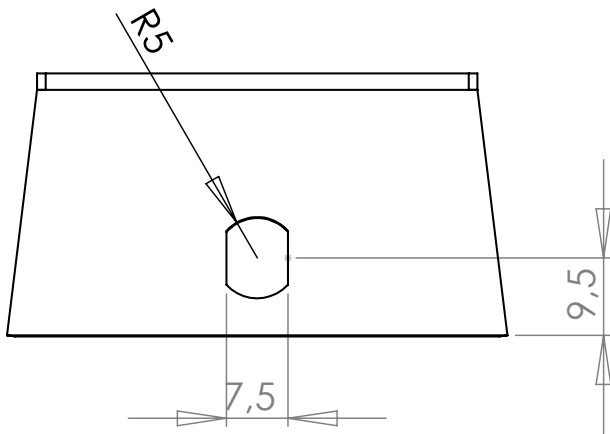

dcw.

Name : **BS1 FLOOR & BS2 WALL**

Materials : PAINTED STEEL

Part : **JUNCTION PIECE**

Date :

Rev : 2

Details :

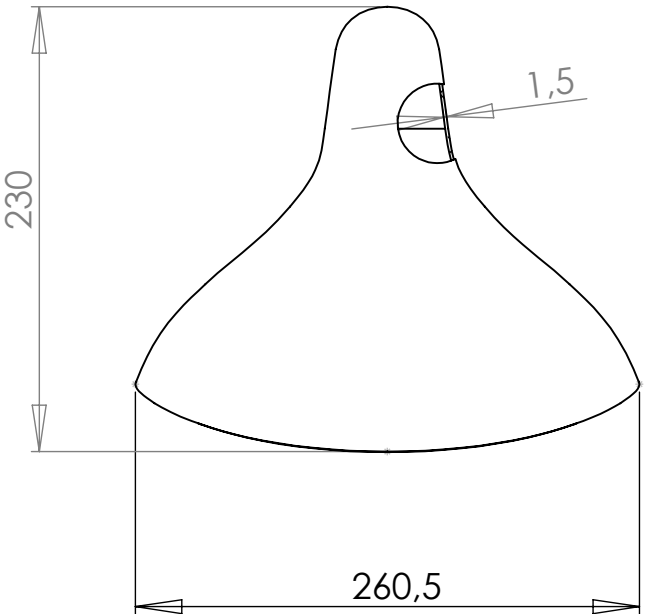
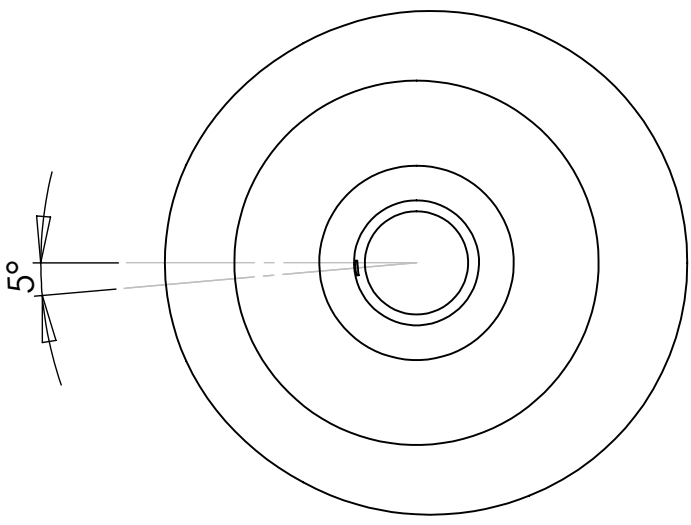
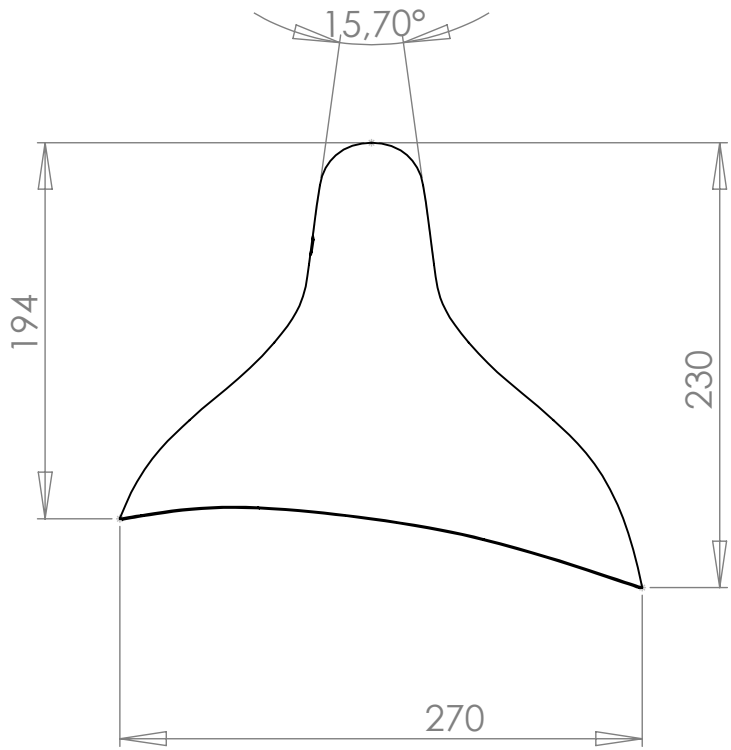
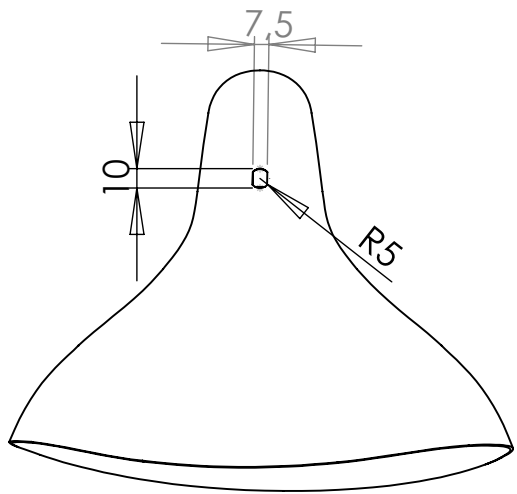

dcw.

Name : BS1 FLOOR & BS2 WALL

Materials : PAINTED ALUMINIUM

Part : SHADE

Date :

Rev : 3

Details :

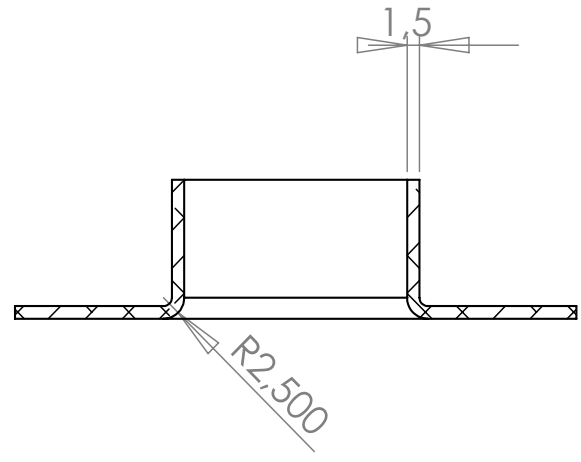
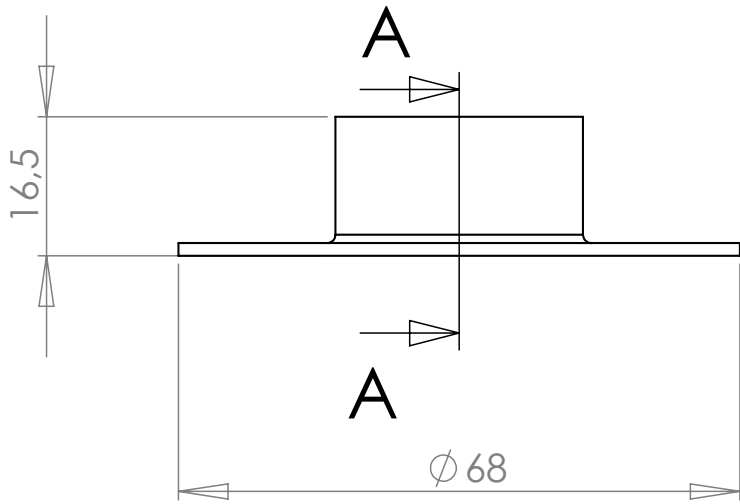

COUPE A-A

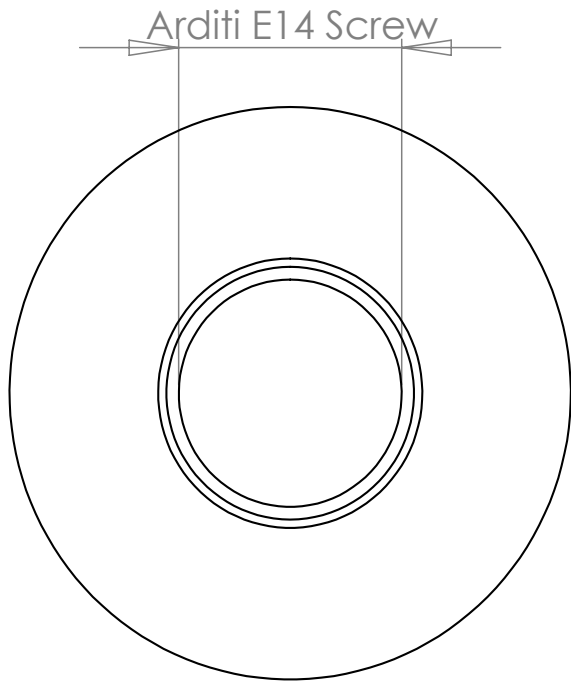

dcw.

Name : **BS1 FLOOR & BS2 WALL**

Matériaux : PAINTED STEEL

Part : **COVER CUP**

Date :

Rev : **2**

Details :