

Qty	Piece	Finishing
1	WALL FIXATION	MAT BLACK
1	WALL PLATE	MAT BLACK
1	WALL TUBE	MAT BLACK
1	BALL PART 1	MAT BLACK
1	BALL PART 2	MAT BLACK
1	HOOK	MAT BLACK
1	TUBE 2	MAT BLACK
1	PIVOT PART 1	MAT BLACK
1	PIVOT PART 2	MAT BLACK
1	TUBE	MAT BLACK
1	CHAIN	NICKELED N8
1	CORD GRIPP	MAT BLACK
1	BALL JOINT	NICKELED N8
1	SHADE	MAT BLACK OUTSIDE / MAT WHITE INSIDE

1	V BAR	MAT BLACK
1	JUNCTION PIECE	MAT WHITE
1	COVER CUP	MAT WHITE
1	THREAD 10x100	
1	BULBHOLDER	
2	M10 x 4 NUT	
1	M4 PLASTIC SCREW	
1	SWITCH	NICKELED
1	WALL HOOK	BLACK

dcw.

Name : **BS2 – BL**

Matérials :

Part : **Finishings**

Date :

Rev : 2

Details : E14 - ESL 11W



Qty	Piece	Finishing			
1	WALL FIXATION	MAT PAINTING - PANTONE 5635U	1	V BAR	MAT PAINTING - PANTONE 5635U
1	WALL PLATE	MAT PAINTING - PANTONE 5635U	1	JUNCTION PIECE	MAT WHITE
1	WALL TUBE	MAT PAINTING - PANTONE 5635U	1	COVER CUP	MAT WHITE
1	BALL PART 1	MAT PAINTING - PANTONE 5635U	1	THREAD 10x100	
1	BALL PART 2	MAT PAINTING - PANTONE 5635U	1	BULBHOLDER	
1	HOOK	MAT PAINTING - PANTONE 5635U	2	M10 x 4 NUT	
1	TUBE 2	MAT PAINTING - PANTONE 5635U	1	M4 PLASTIC SCREW	
1	PIVOT PART 1	MAT PAINTING - PANTONE 5635U	1	SWITCH	
1	PIVOT PART 2	MAT PAINTING - PANTONE 5635U	1	WALL HOOK	MAT PAINTING - PANTONE 5635U
1	TUBE	MAT PAINTING - PANTONE 5635U			
1	CHAIN	NICKELED N8			
1	CORD GRIPP	MAT PAINTING - PANTONE 5635U			
1	BALL JOINT	NICKELED N8			
1	SHADE	SATIN BLACK BK11 OUTSIDE / MAT WHITE INSIDE			

dcw.

Name : **BS2 BR-BL**

Matérials :

Part : **Finishings**

Date :

Rev : 2

Details : E14 - ESL 11W

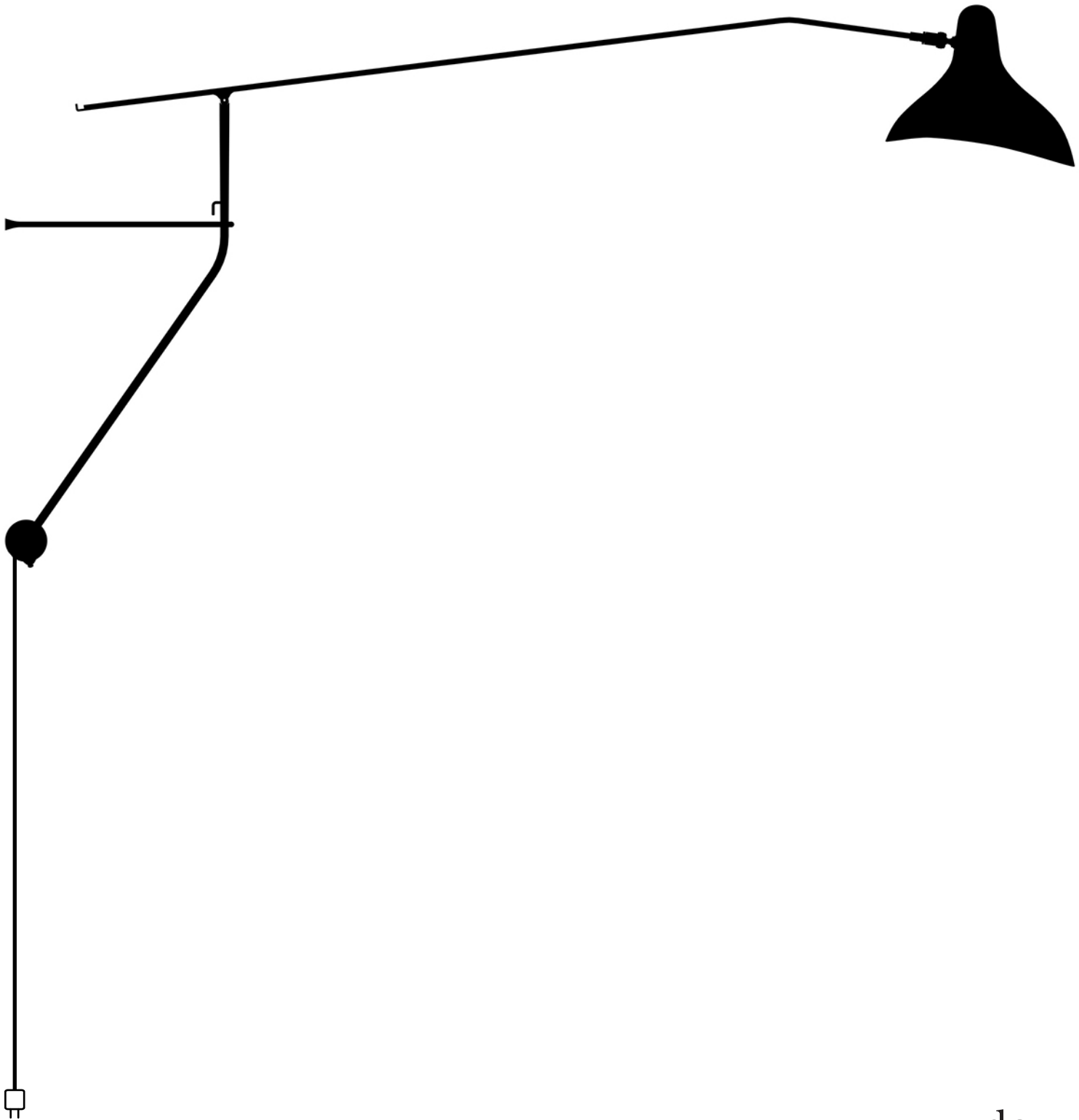

dcw.

Name : **BS2 WALL**

Matérials :

Part : **ELEC LENGHT**

Date :

Rev : 2

Details :

Name : **BS2 WALL**
Part : **ELEMENTS**
Date :

Rev : **3**

Materials :
Details :

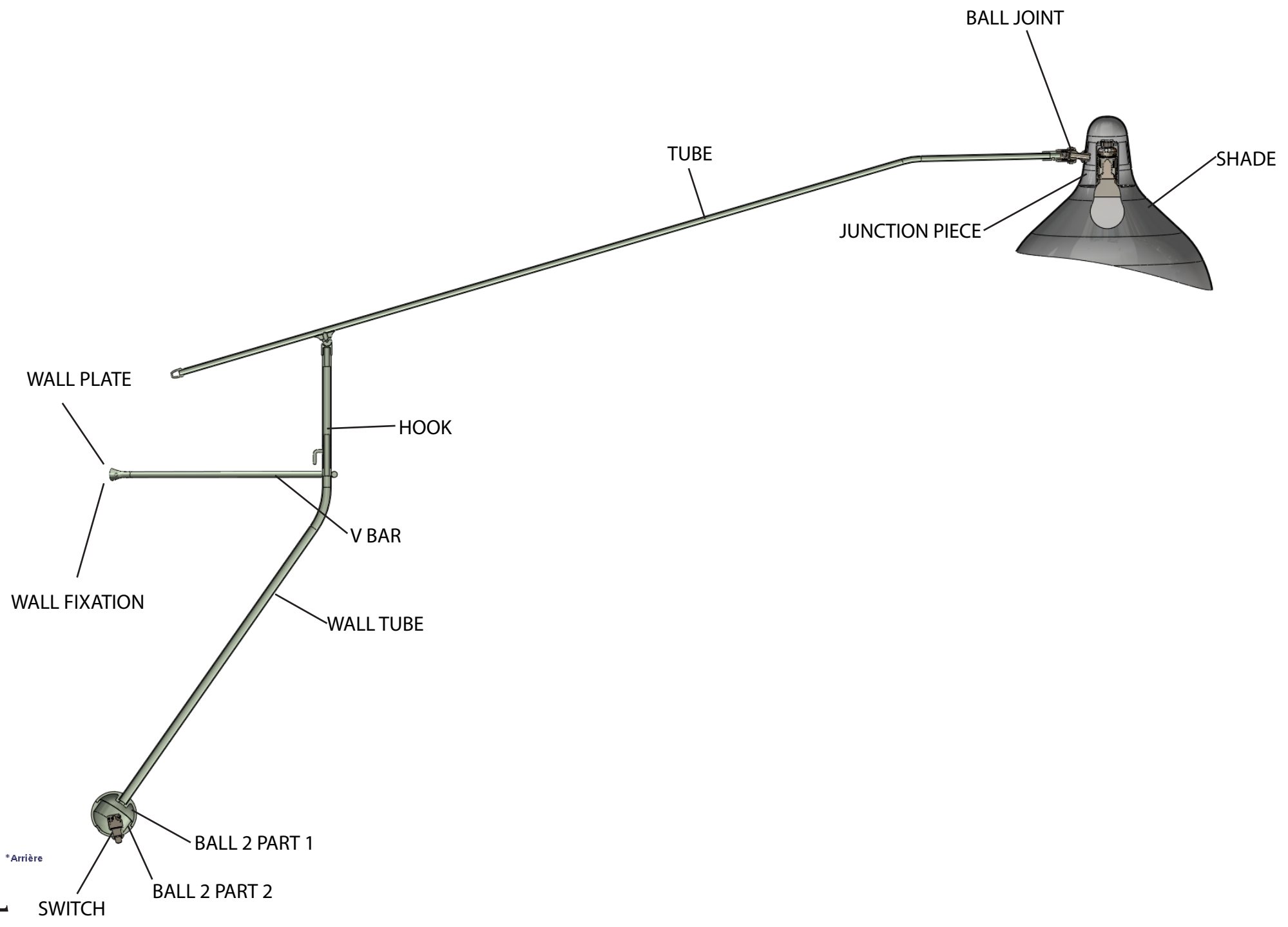

dcw.

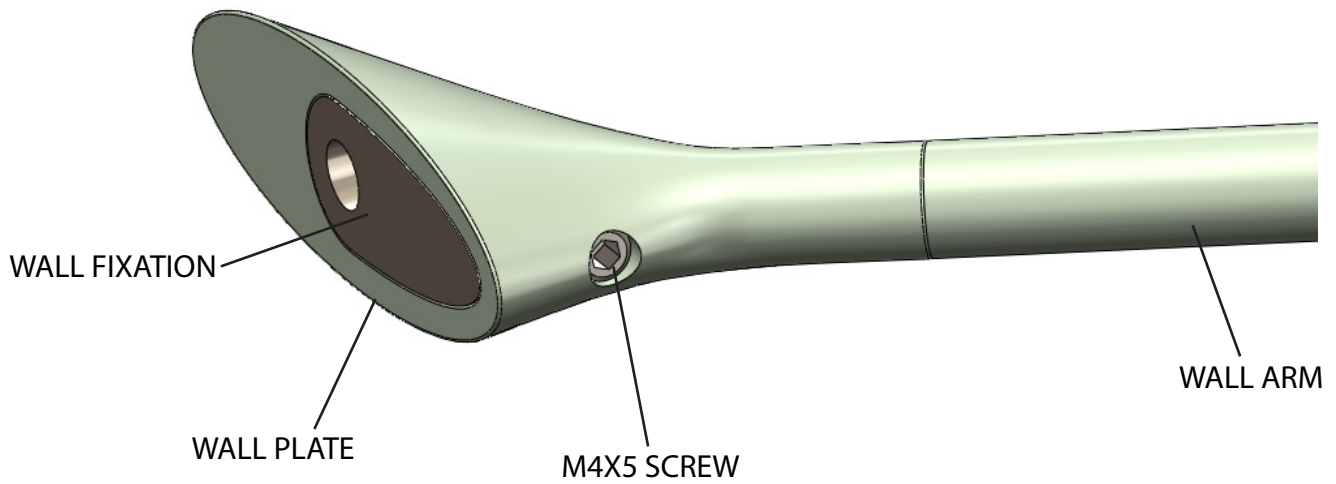
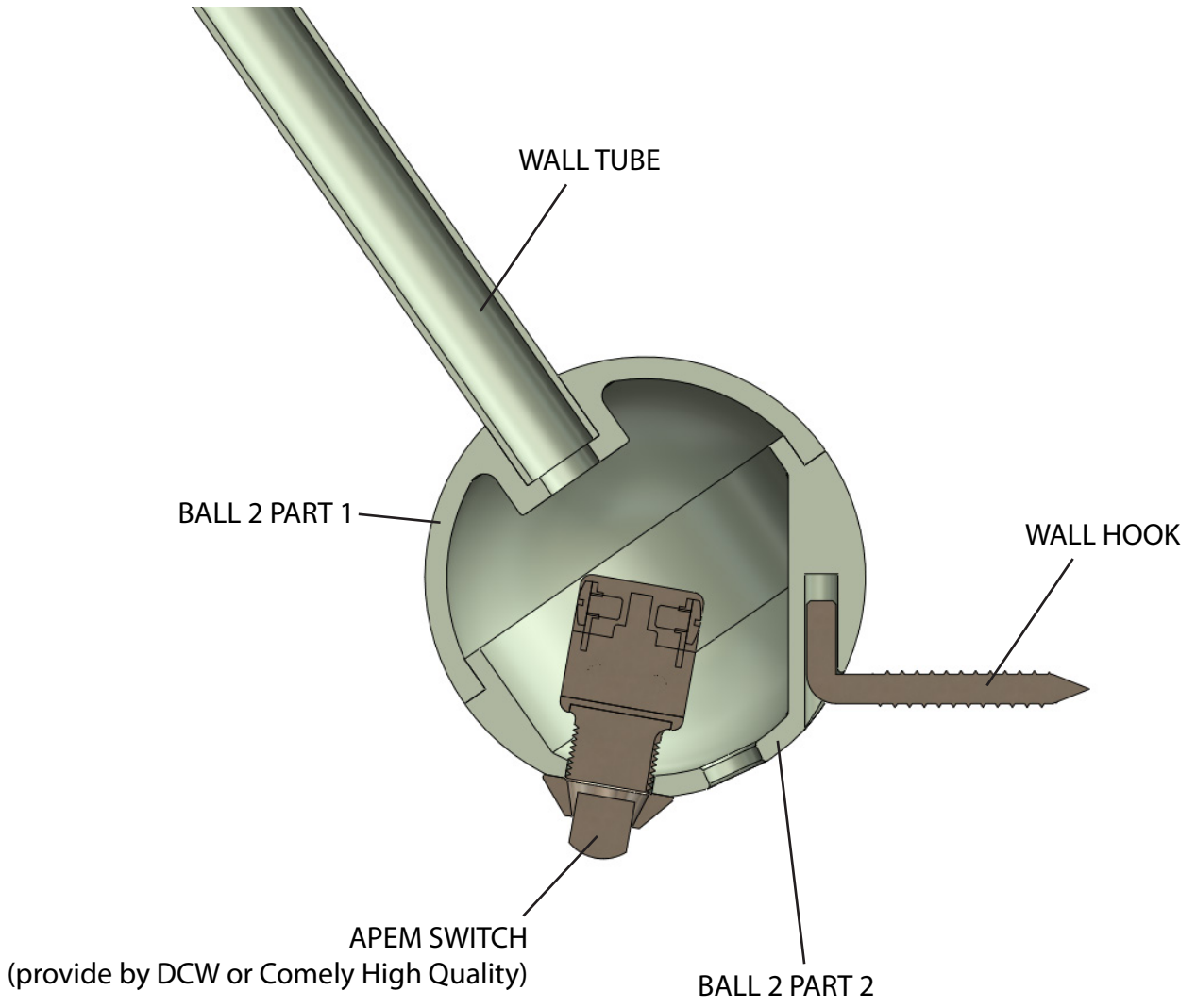

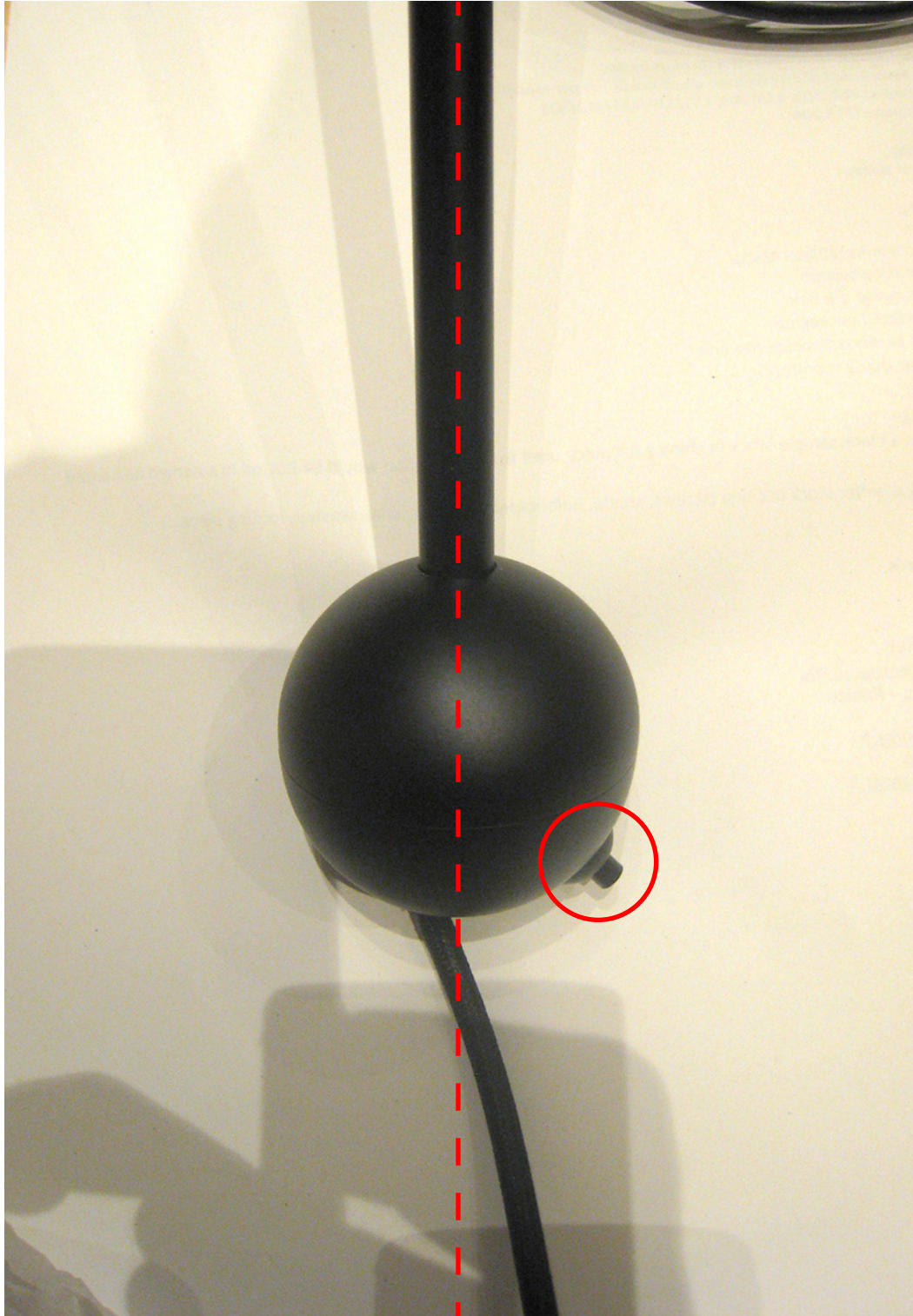

The switch must be aligned with the tube

dcw.

Name : **BS2 WALL**

Part : **SWITCH POSITION**

Date :

Rev : **1**

Materials :

Details :

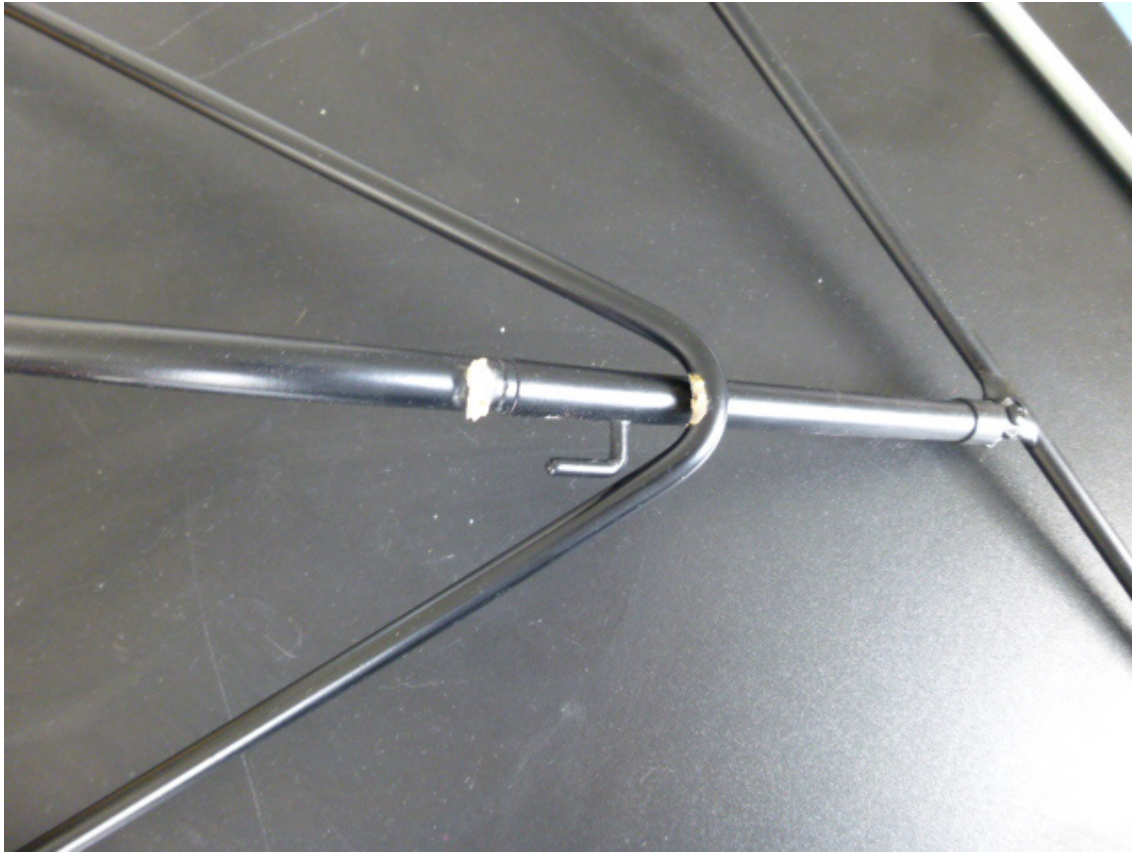

You should be very careful with the welding .
Maybe brazing is not enough strong .
We can accept to see more welding.



dcw.

Name : **BS2 WALL**

Part : **WELDING DETAIL**

Date :

Rev : **1**

Matériaux :

Details :

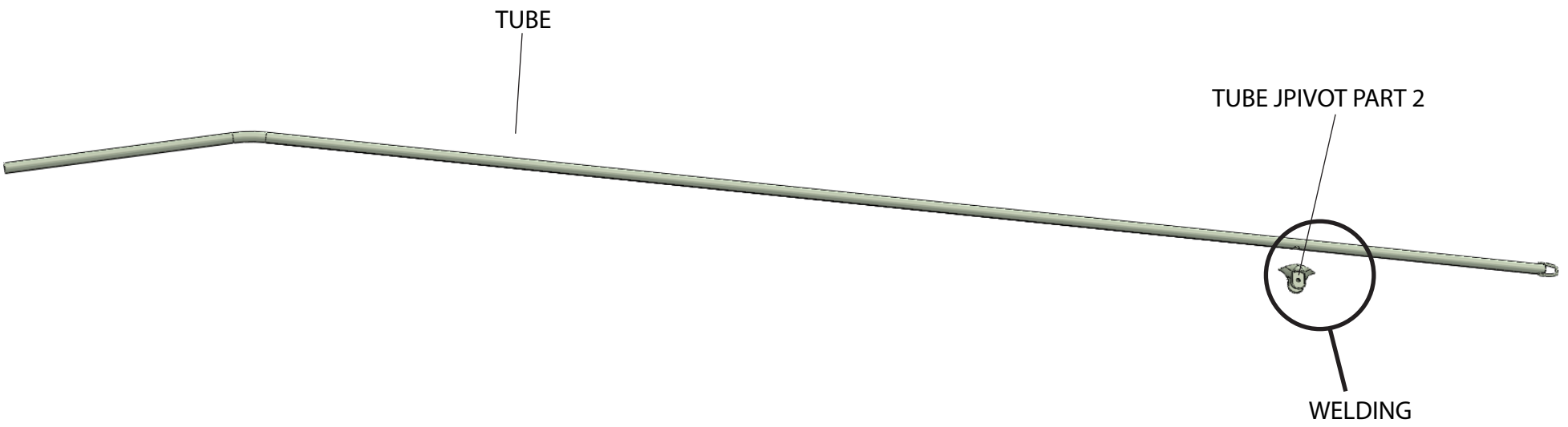

Name : **BS2 WALL**

Part : **TUBE DETAILS**

Date :

Rev : 2

Materials :

Details :

dcw.

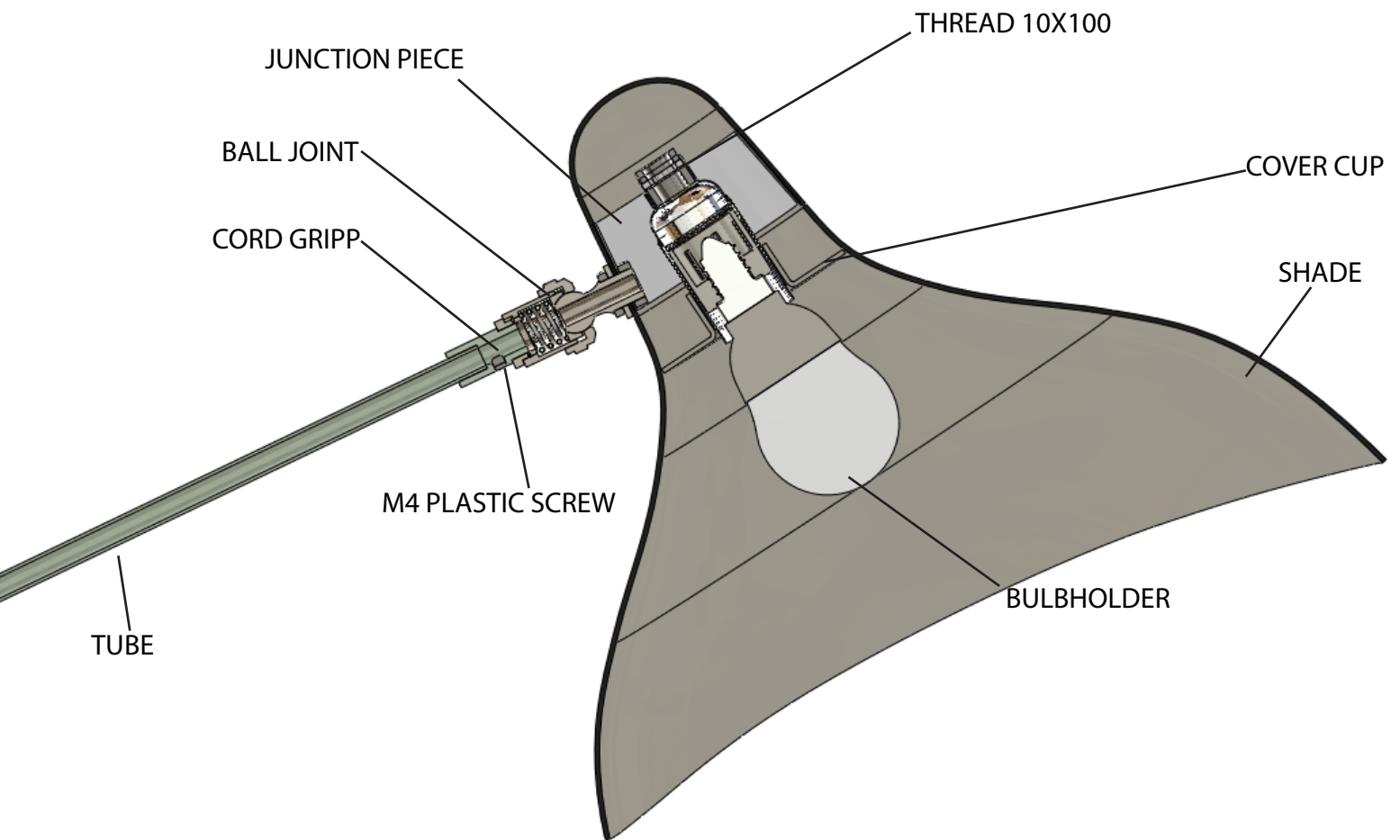

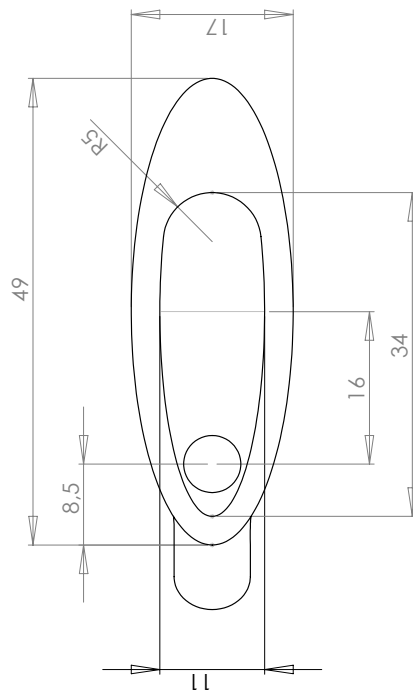
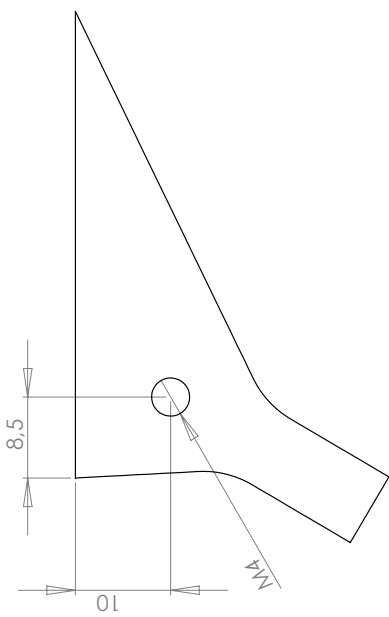
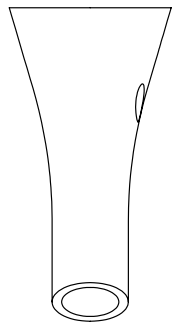
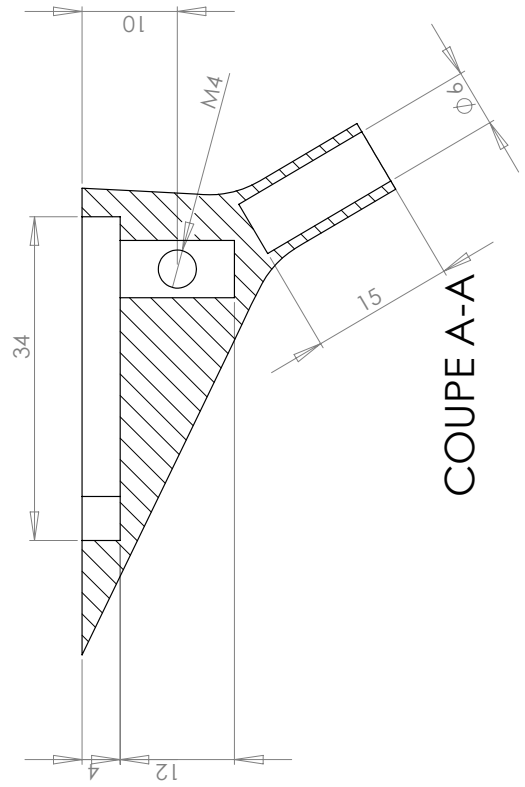
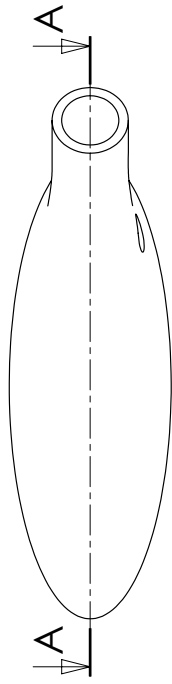
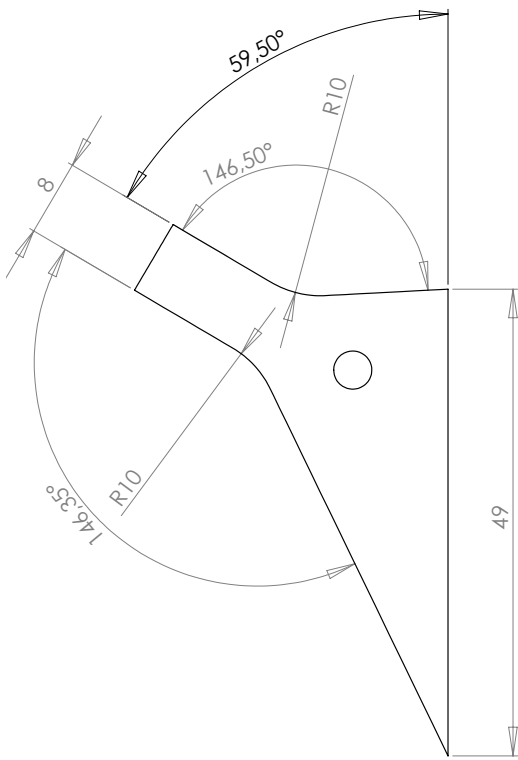

dcw.

Name : **BS2 WALL**

Materials : PAINTED STEEL CAST

Part : **WALL PLATE**

Date :

Rev : **2**

Details :

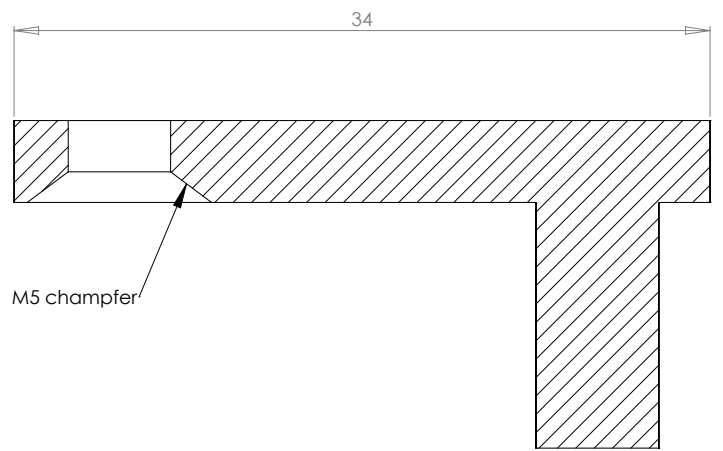
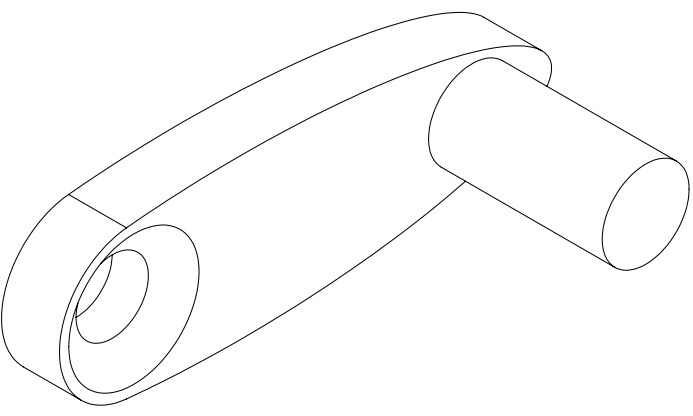
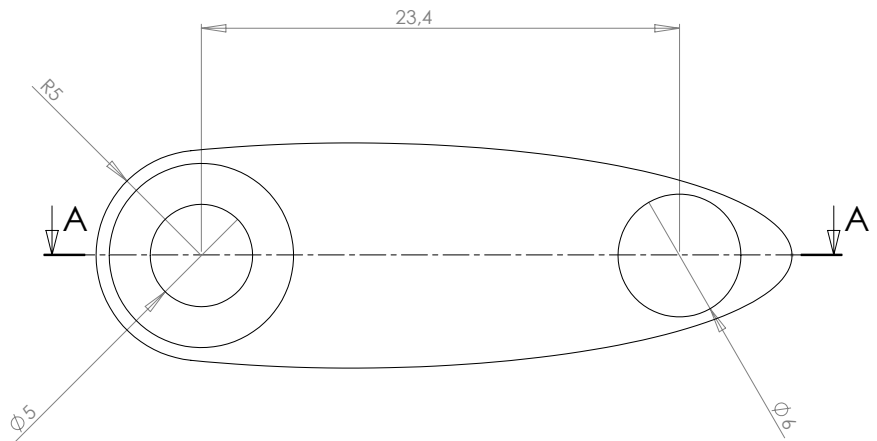
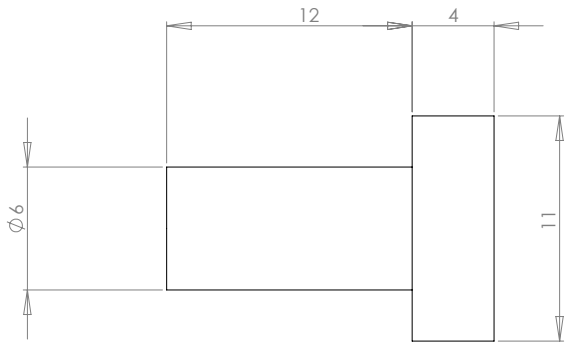

COUPE A-A

dcw.

Name : **BS2 WALL**

Materials : PAINTED STEEL

Part : **WALL FIXATION**

Date :

Rev : **2**

Details :

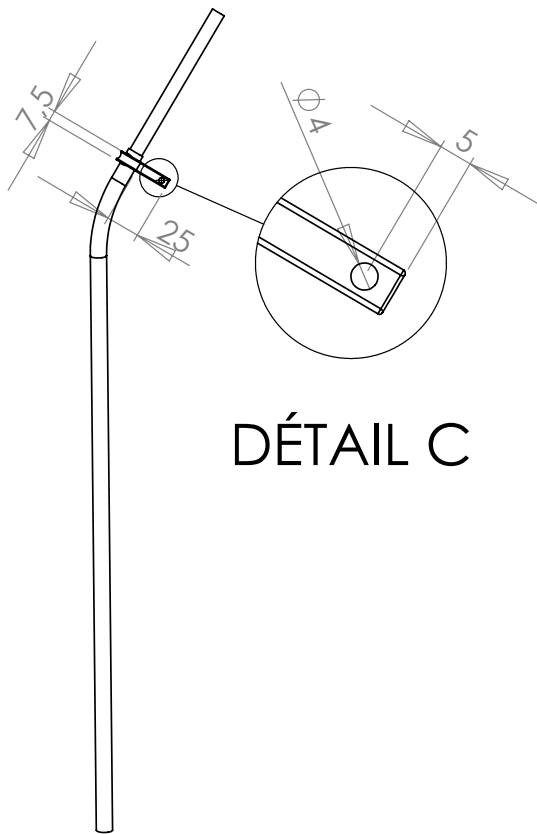
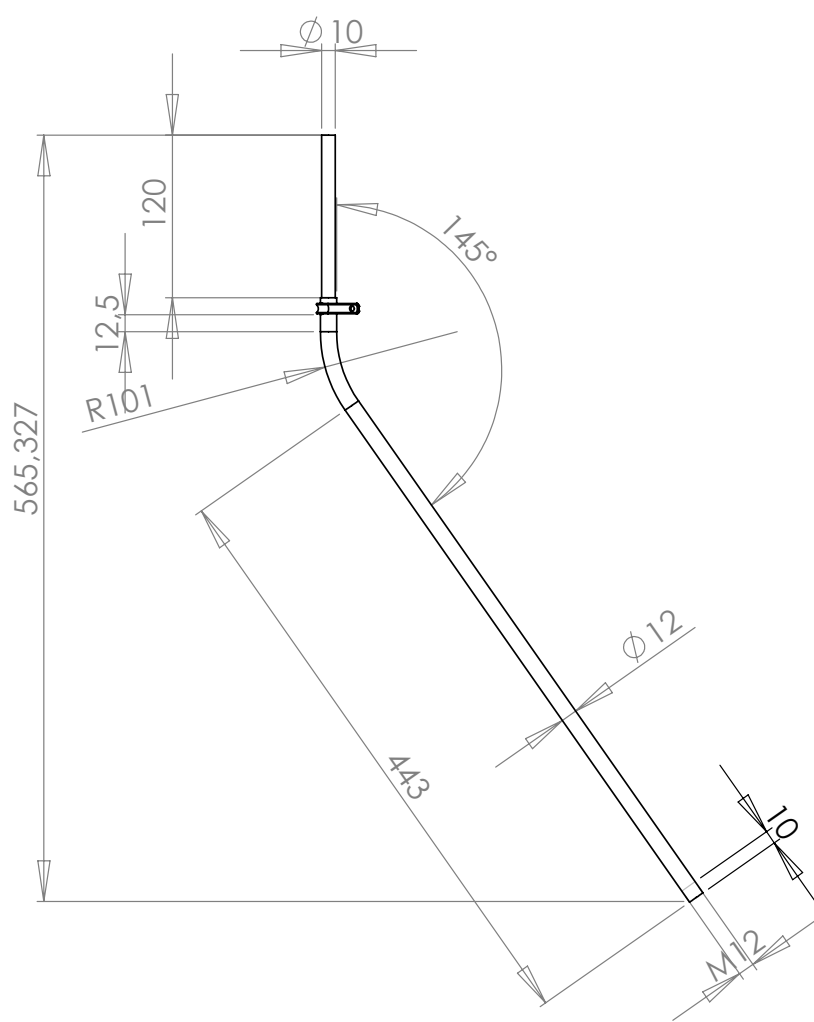

DÉTAIL C

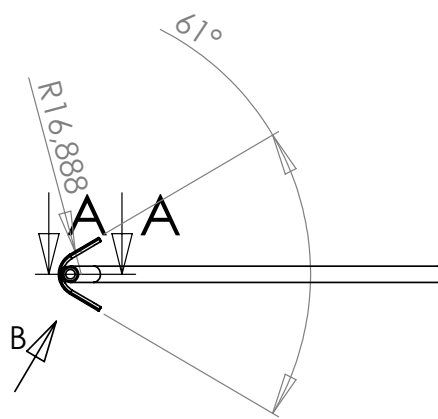

COUPE A-A

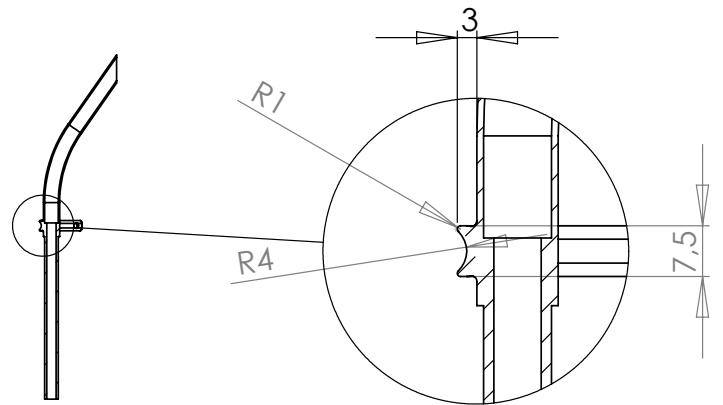

DÉTAIL D

dcw.

Name : **BS2 WALL**

Materials : PAINTED STEEL

Part : **WALL TUBE**

Date :

Rev : **1**

Details :

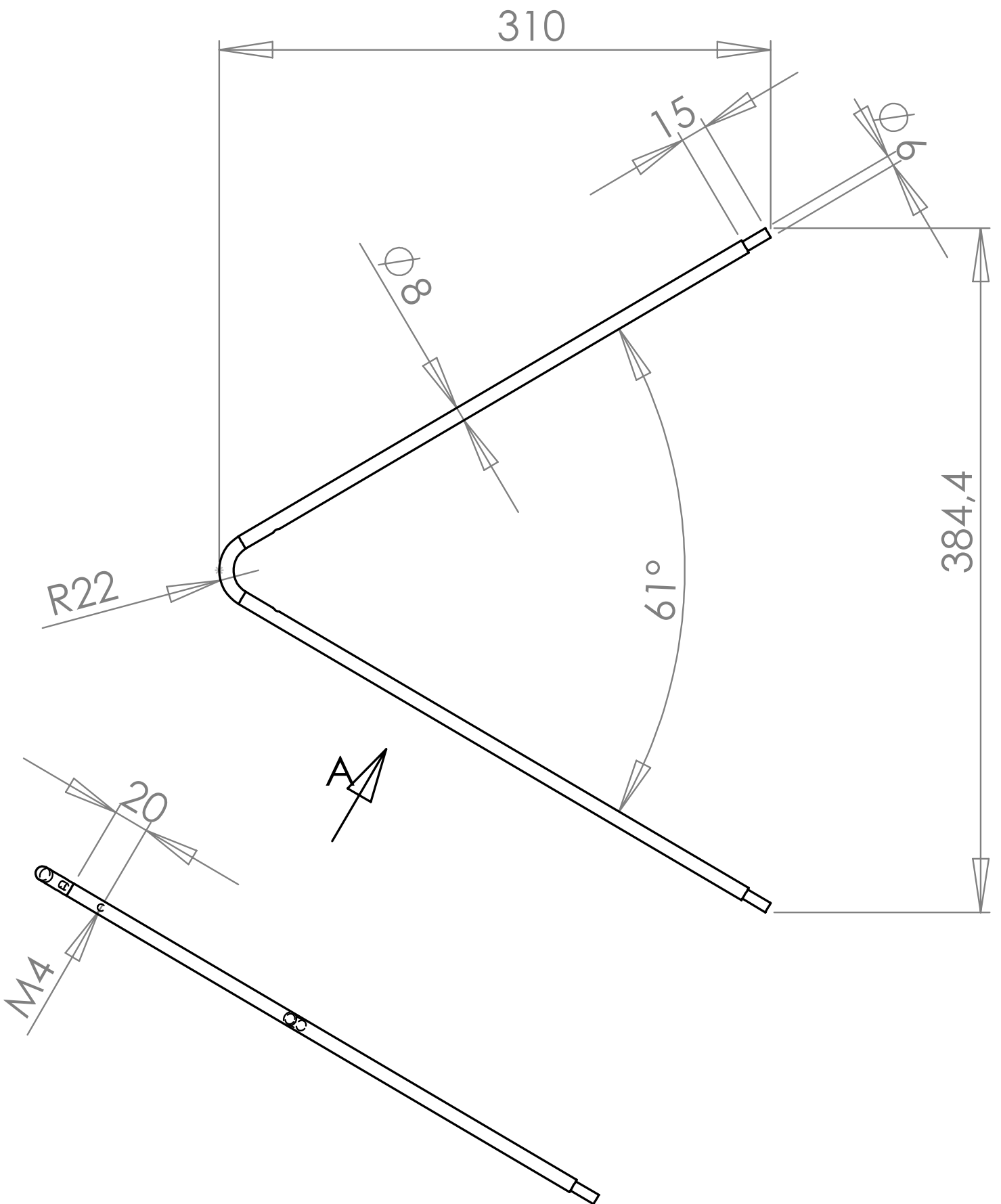

VUE A

dcw.

Name : BS2 WALL

Materials : PAINTED STEEL

Part : V BAR

Date :

Rev : 1

Details :

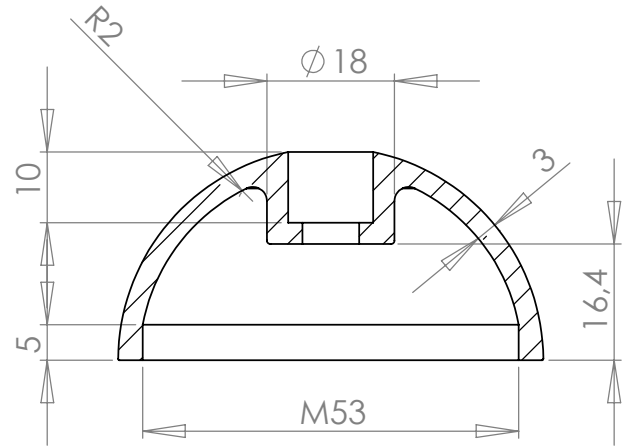
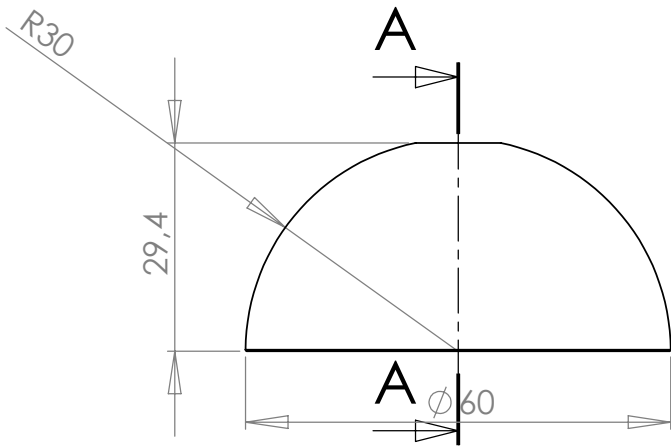
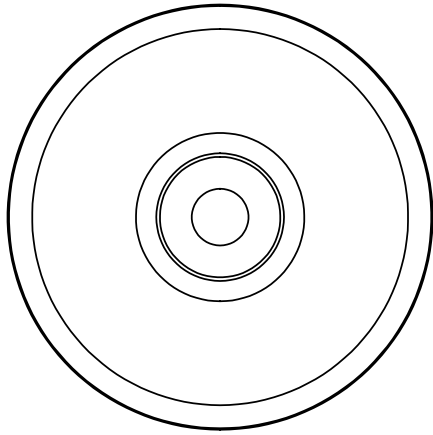

COUPE A-A

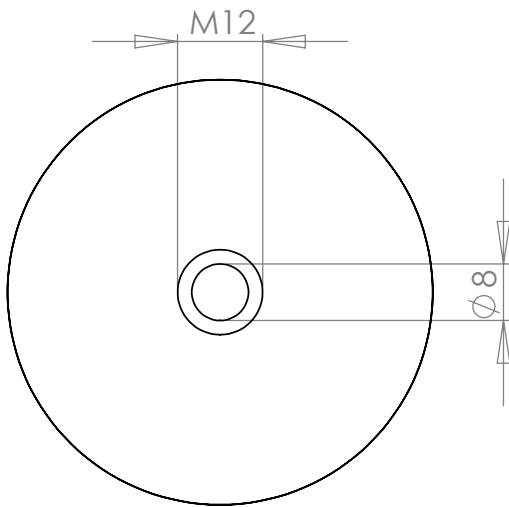

dcw.

Name : **BS Wall**

Matériaux : PAINTED STEEL

Part : **BALL 2 part 1**

Date :

Rev : 1

Details :

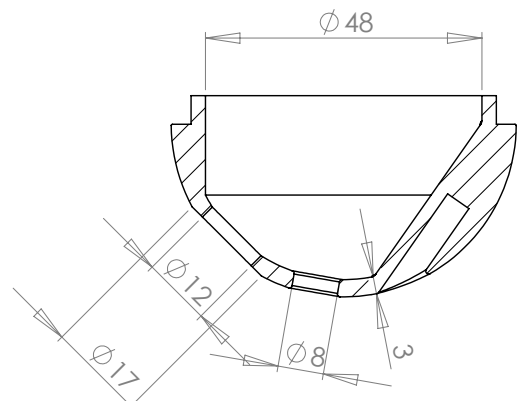
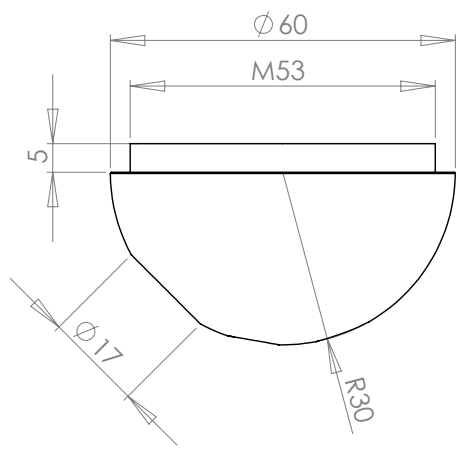
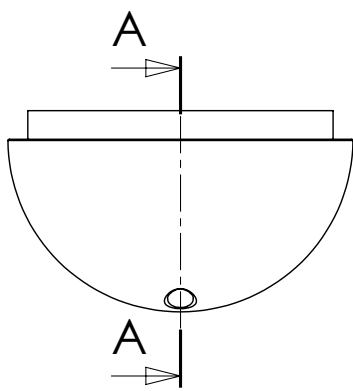
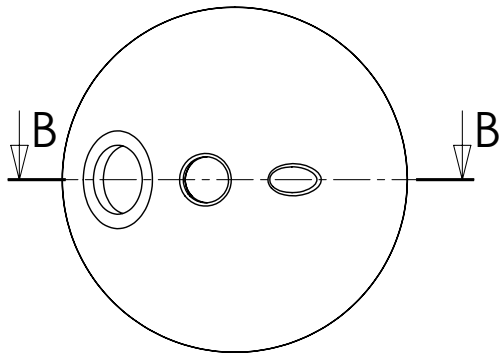

COUPE A-A

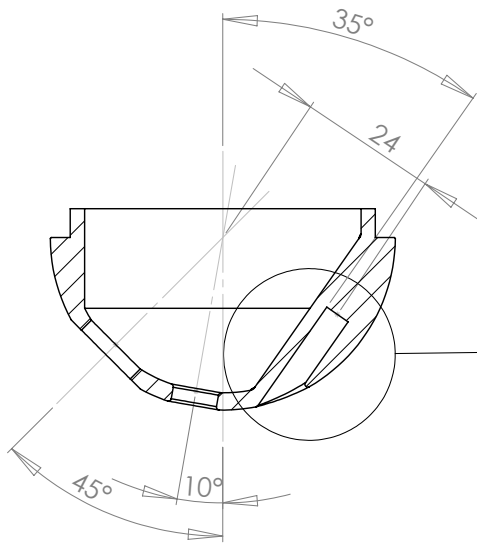
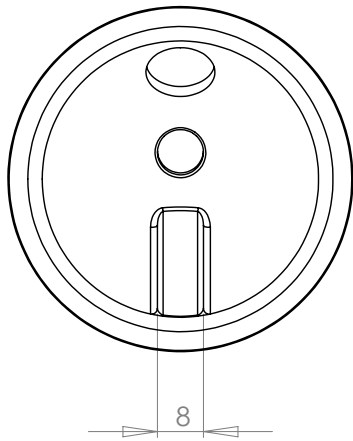

COUPE B-B

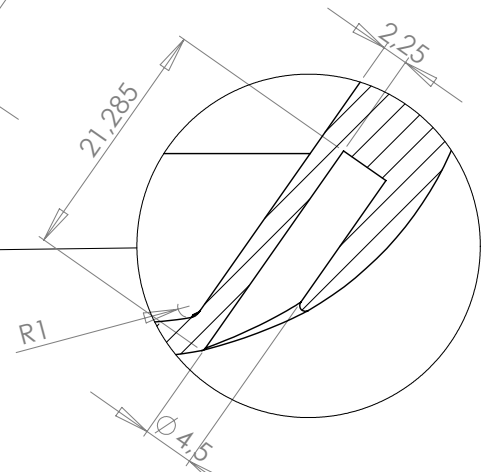

DÉTAIL C

dcw.

Name : **BS2 WALL**

Materials : PAINTED STEEL

Part : **BALL PART 2**

Date :

Rev : 1

Details :

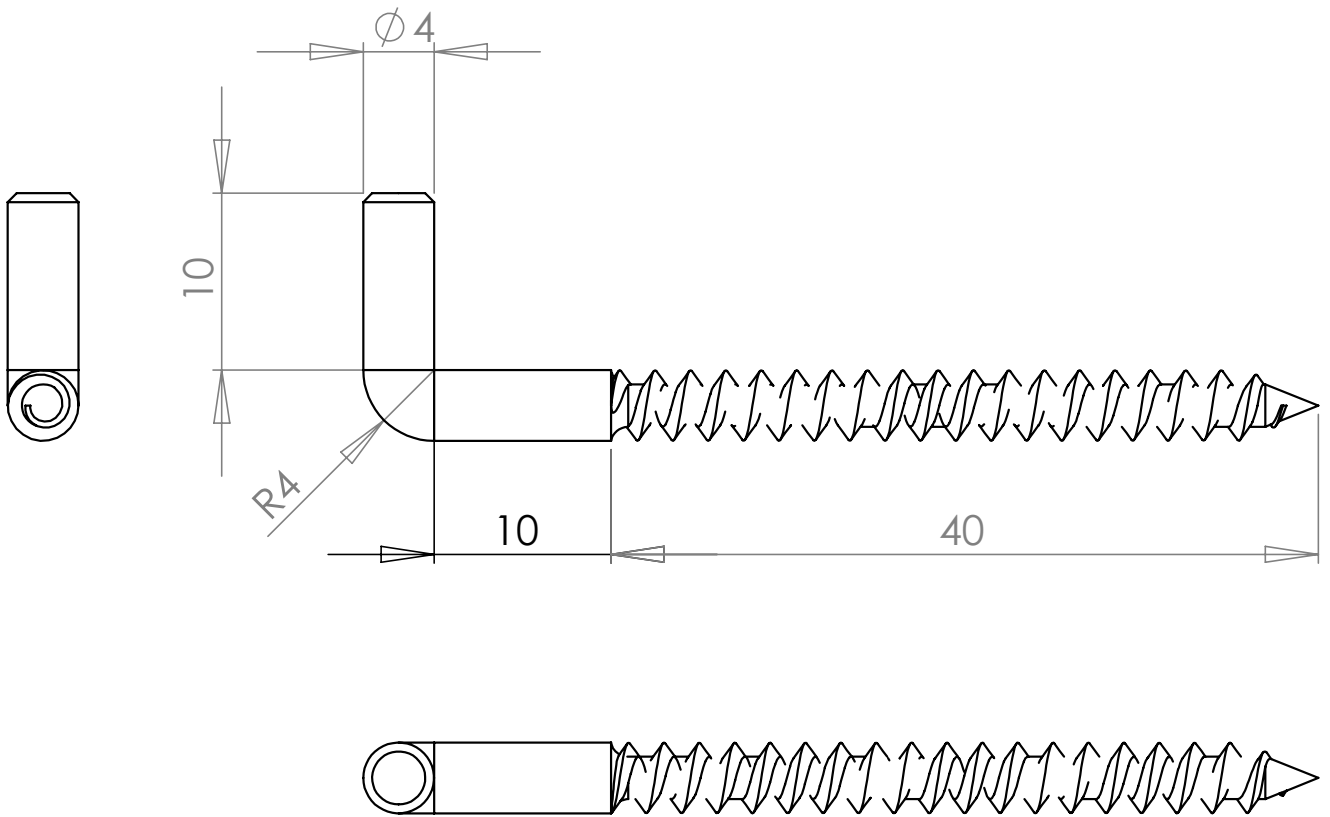

dcw.

Name : **BS2 WALL**

Materials : NICKELLED STEEL

Part : **WALL HOOK**

Date :

Rev : **2**

Details :

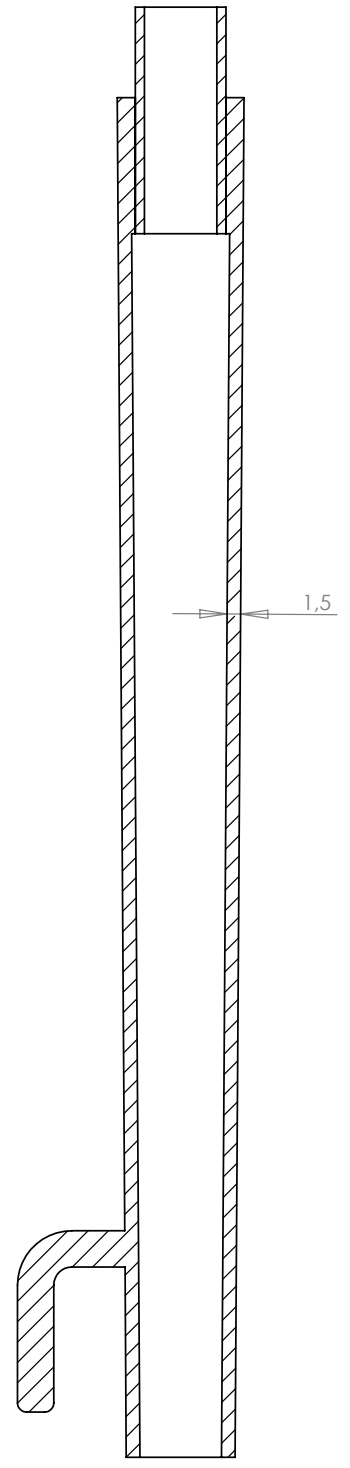
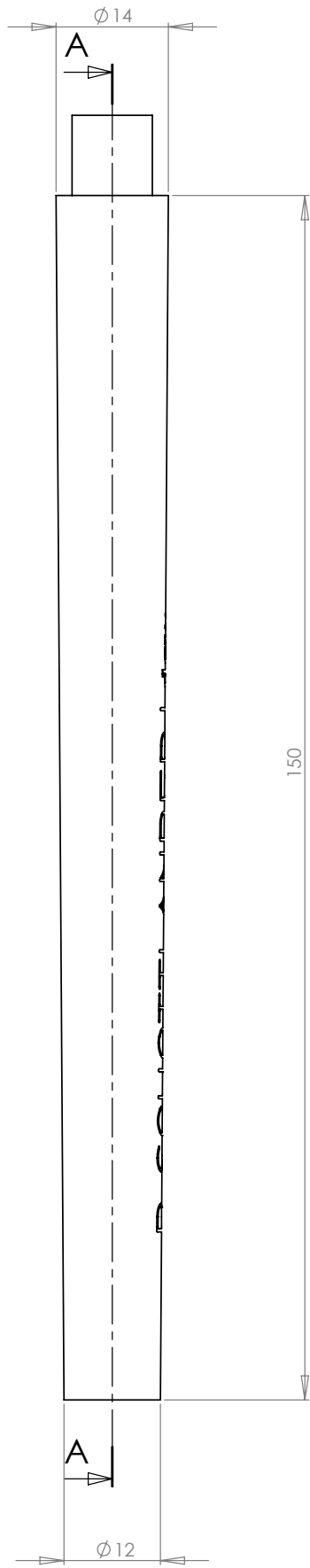
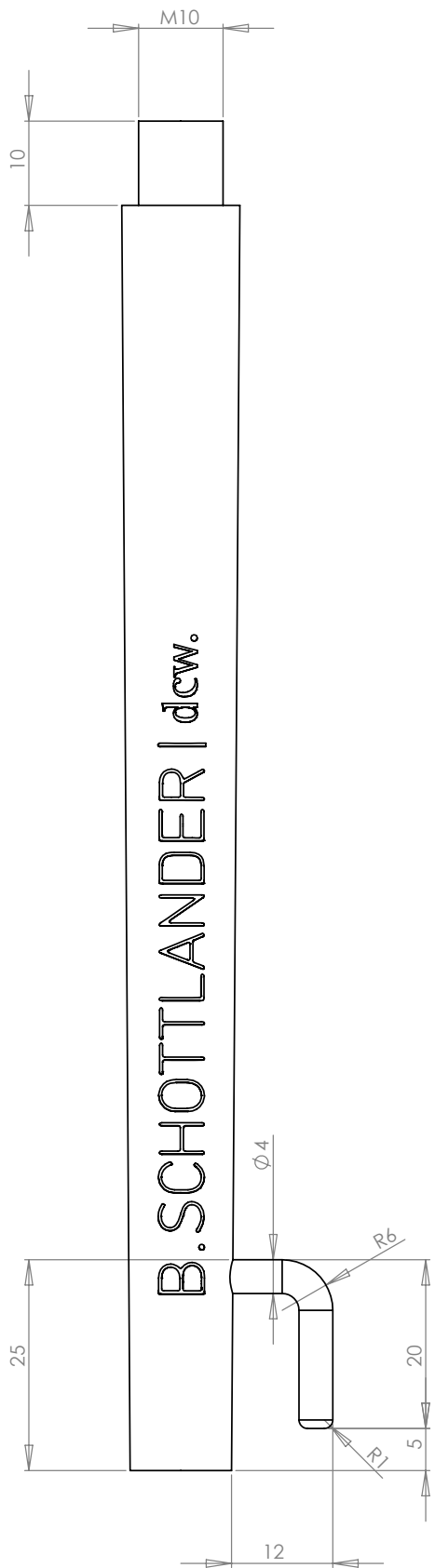

COUPE A-A

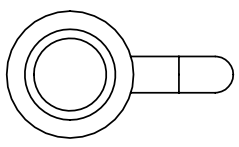

dcw.

Name : **BS2 WALL**

Materials : PAINTED STEEL

Part : **HOOK**

Date :

Rev : **3**

Details :

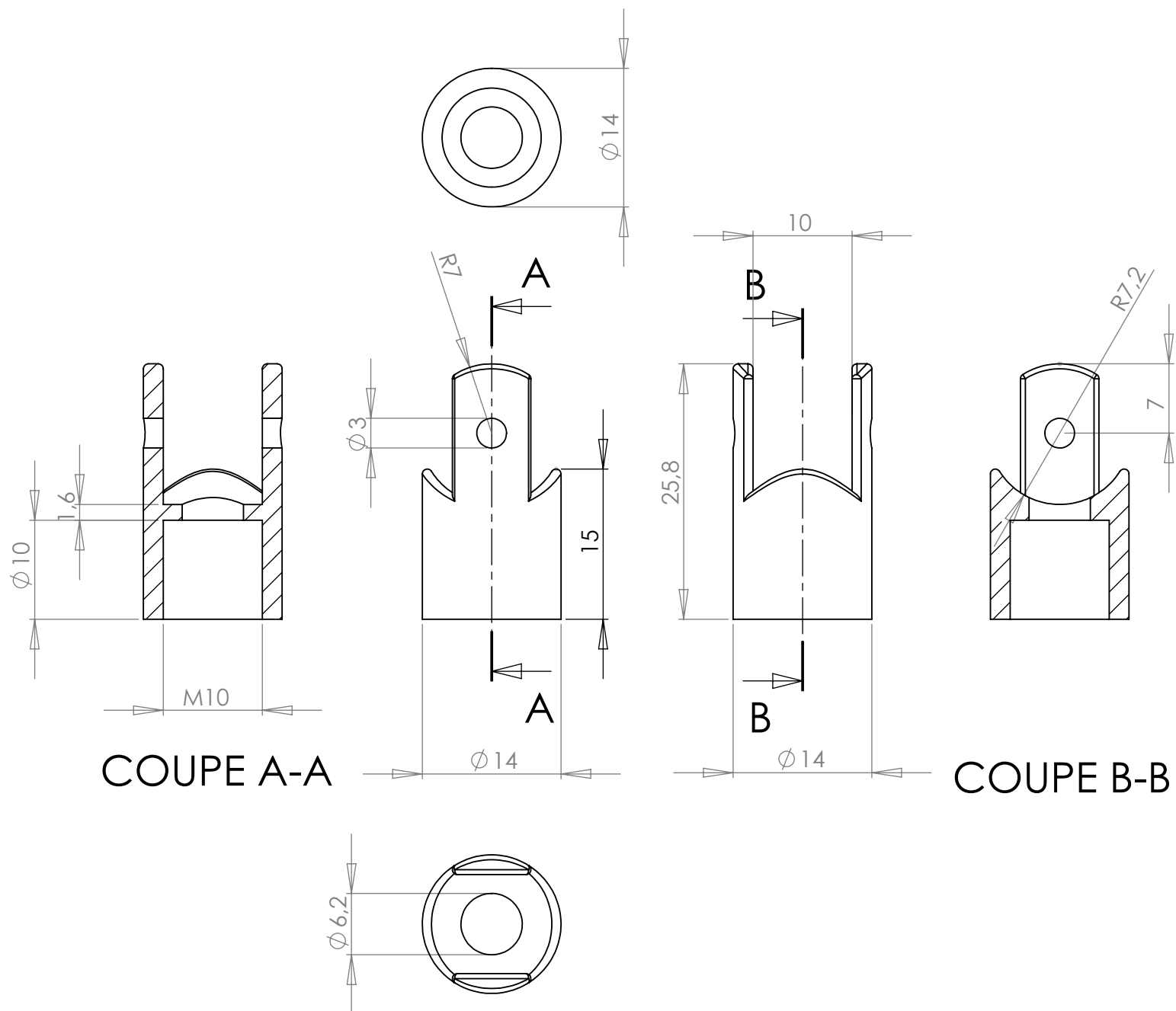

dcw.

Name : **BS2 WALL**

Materials : PAINTED STEEL

Part : **TUBE PIVOT PART 2**

Date :

Rev : 2

Details :

Name : **BS2 WALL**
Part : **TUBE PIVOT PART 1**
Date :

Rev : 2

Materials : **PAINTED STEEL**
Details :

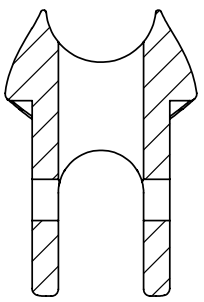
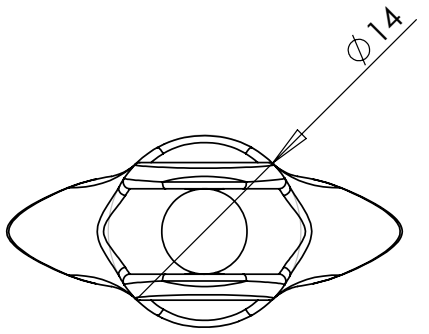

COUPE A-A

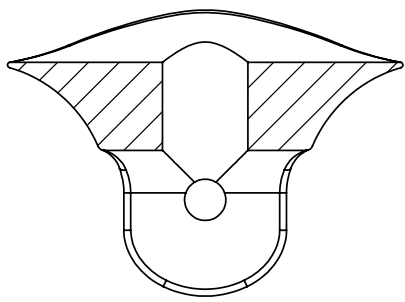
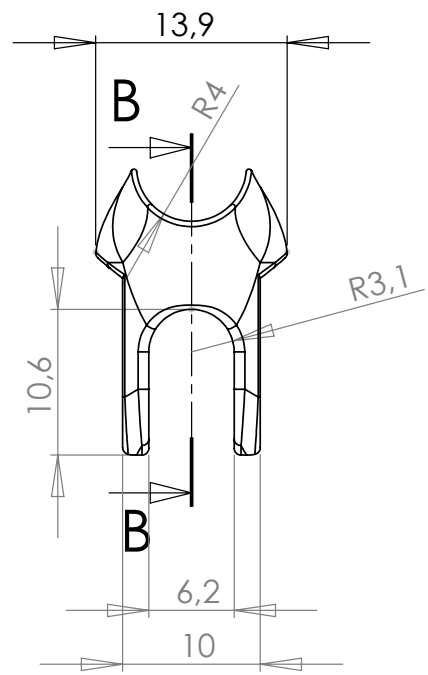
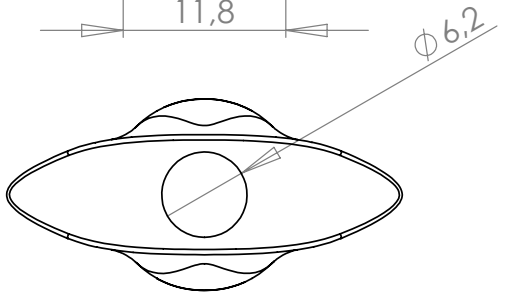
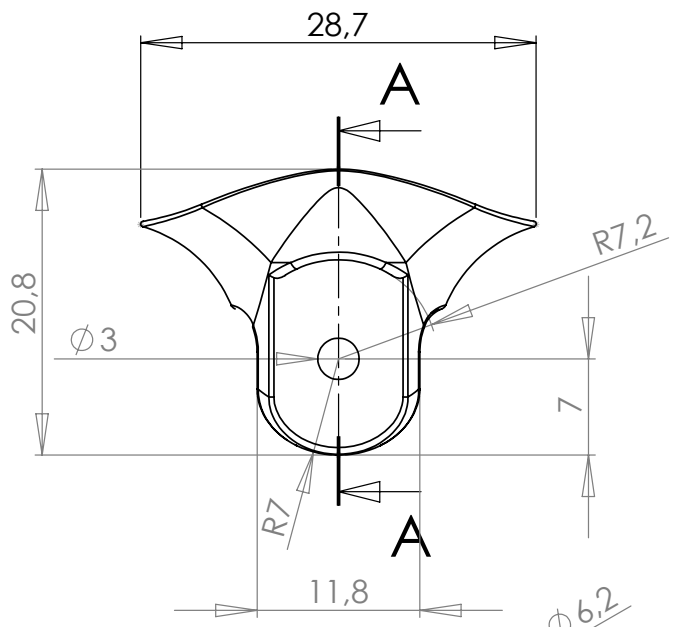

COUPE B-B

Name : **BS2 WALL**
Part : **TUBE**
Date :

Rev : **4**

Materials : PAINTED STEEL 15CDV6 or 25CD4S
Details :

dcw.

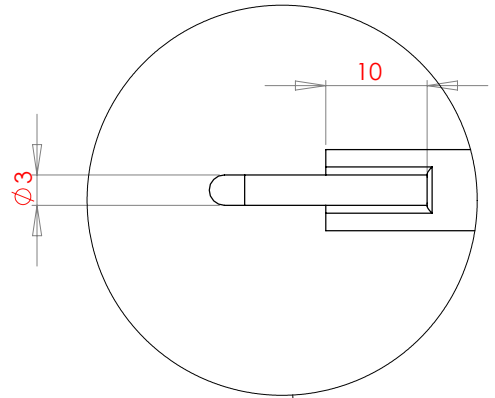

DÉTAIL C

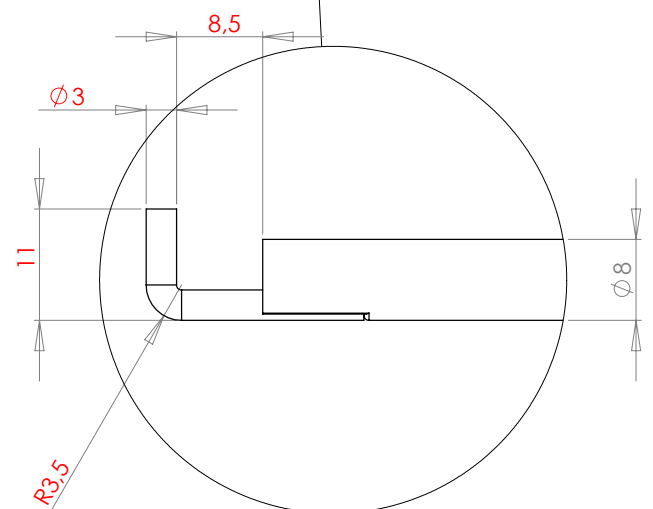
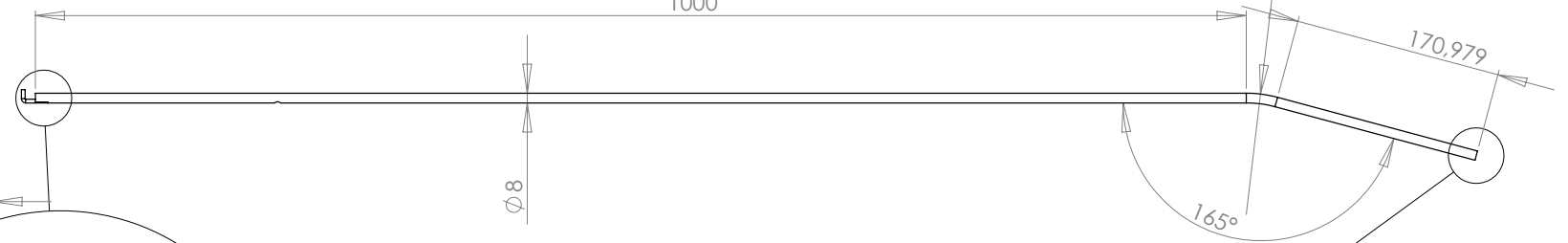
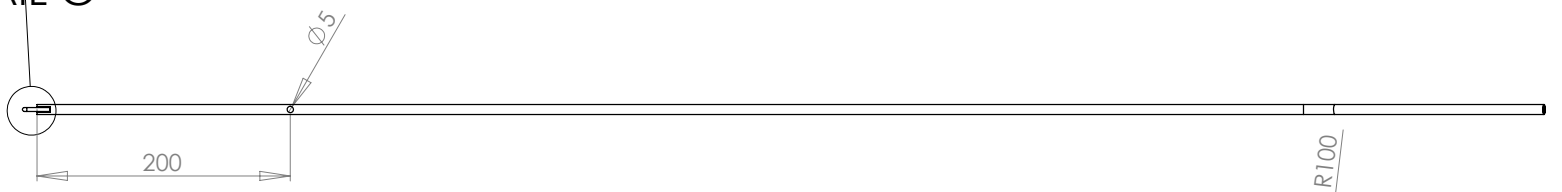

DÉTAIL A

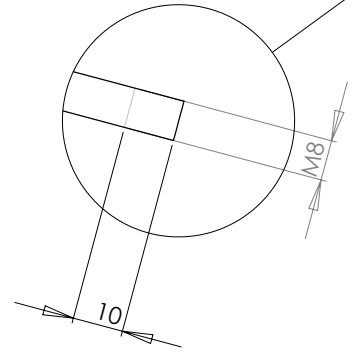

DÉTAIL B

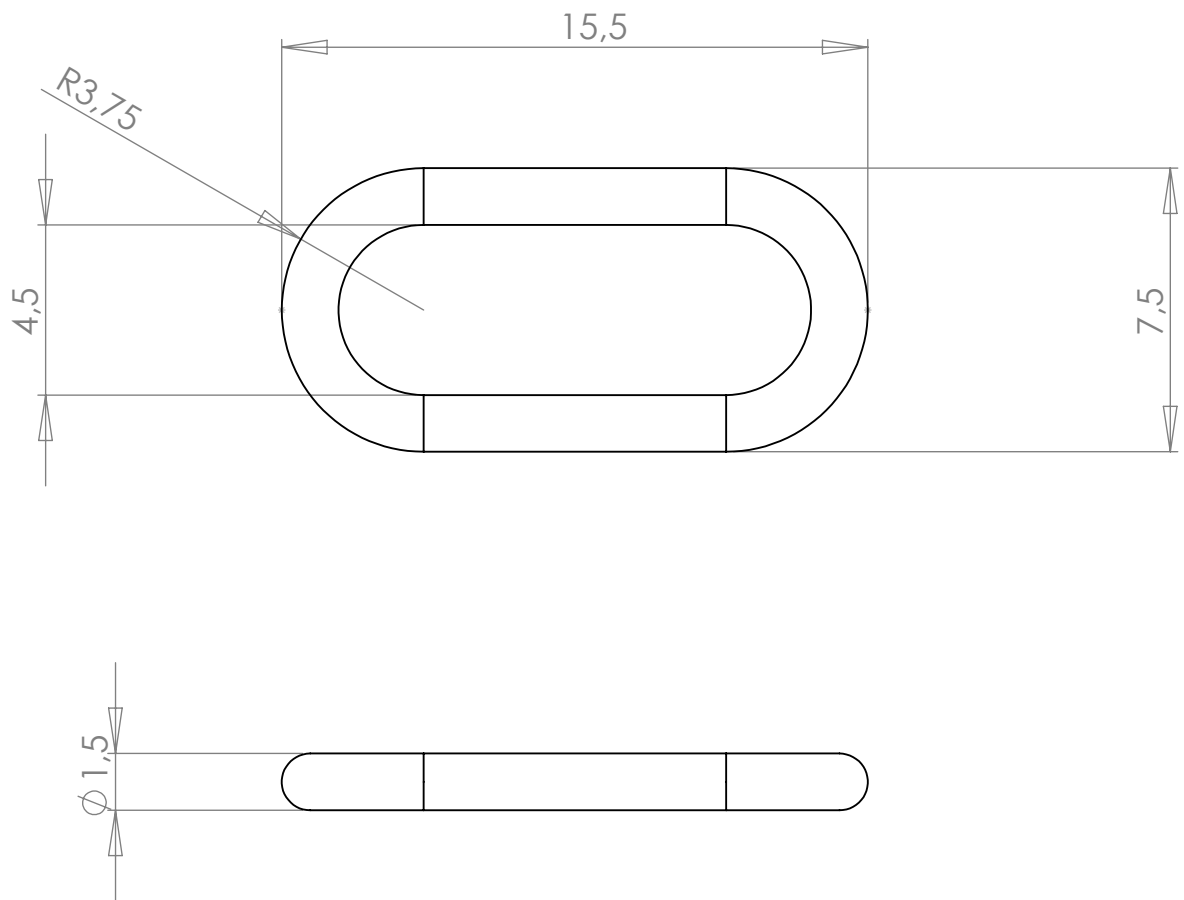

dcw.

Name : **BS2 WALL**

Materials : PAINTED STEEL

Part : **CHAIN**

Date :

Rev : 1

Details :

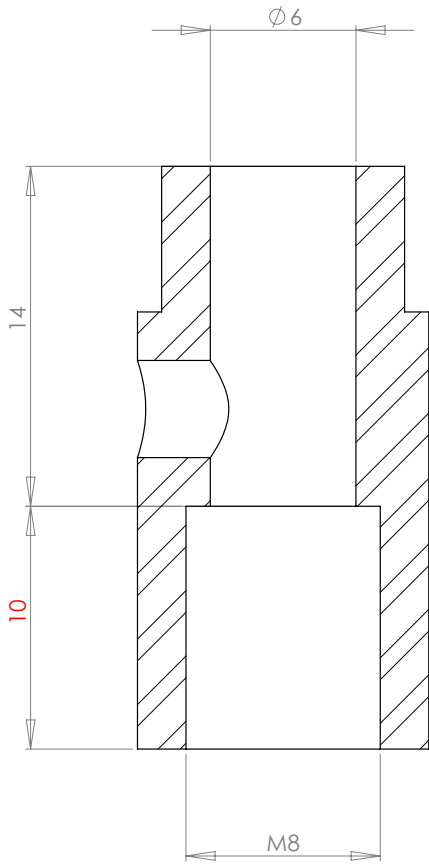

COUPE A-A

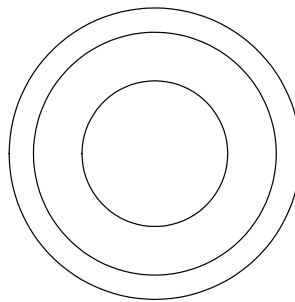
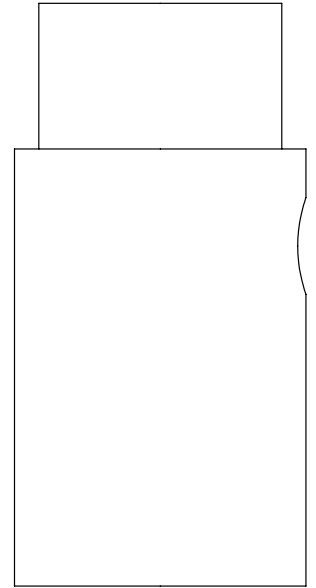
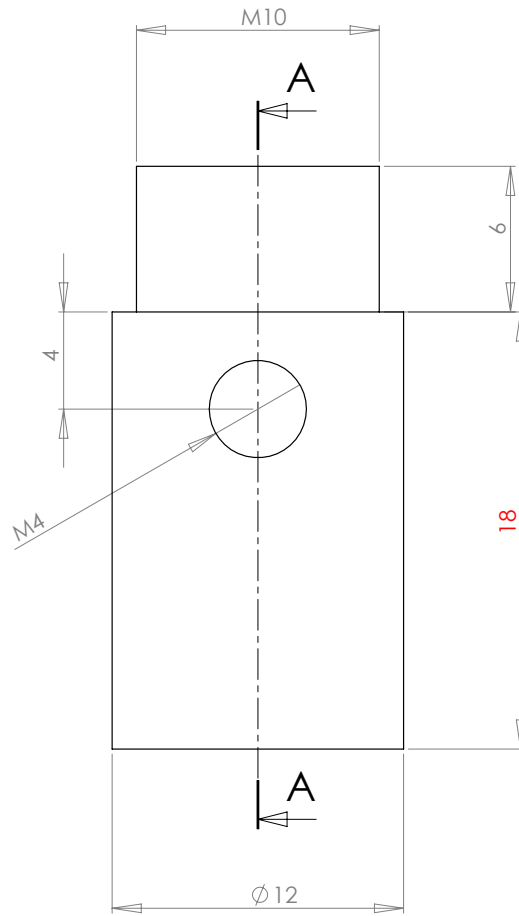

dcw.

Name : **BS RANGE**

Materials : PAINTED STEEL

Part : **CORD GRIPP**

Date :

Rev : 2

Details :



BALL JOINT WASHER



HEXAGON NUT M10x4

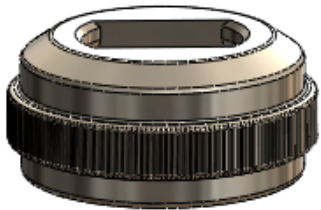

BALL JOINT PART 4

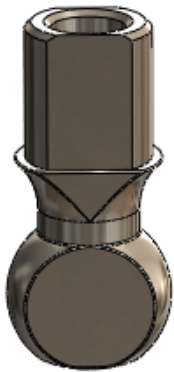

BALL JOINT PART 1

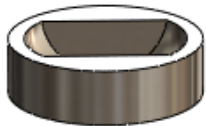

BALL JOINT PART 2

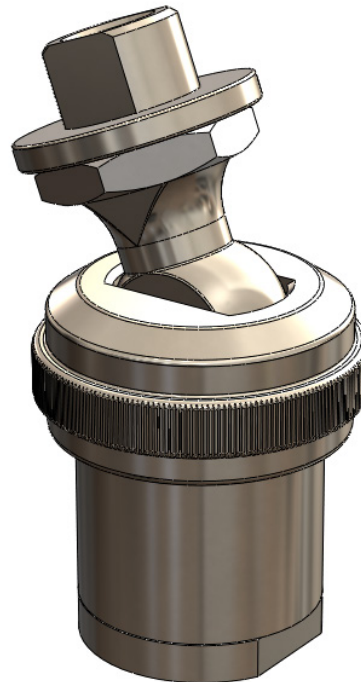

SPRING



BALL JOINT PART 3



CIRCLIP

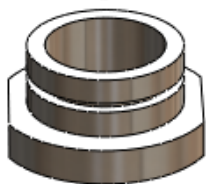

BALL JOINT PART 5

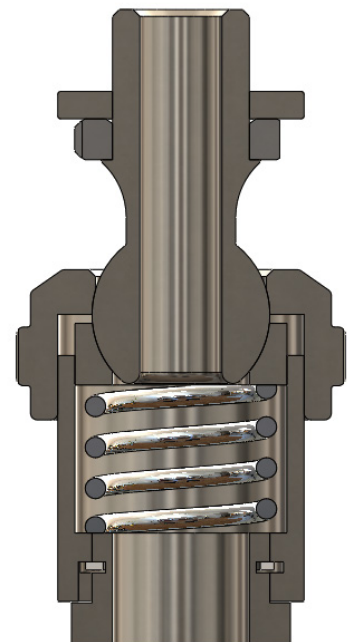
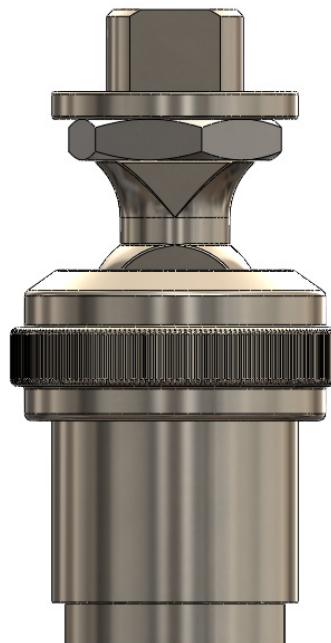

dcw.

Name : **BS RANGE**

Materials : NICKEL PLATED BRASS / PAINTED BRASS

Part : **BALL JOINT DETAILS**

Date :

Rev : **2**

Details :

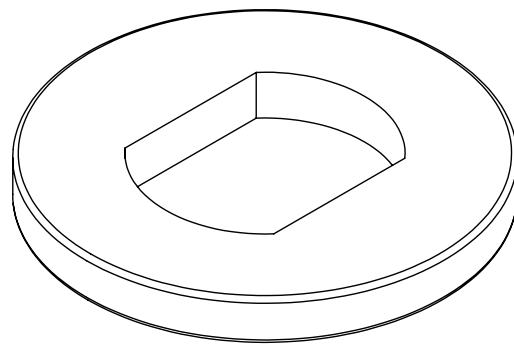
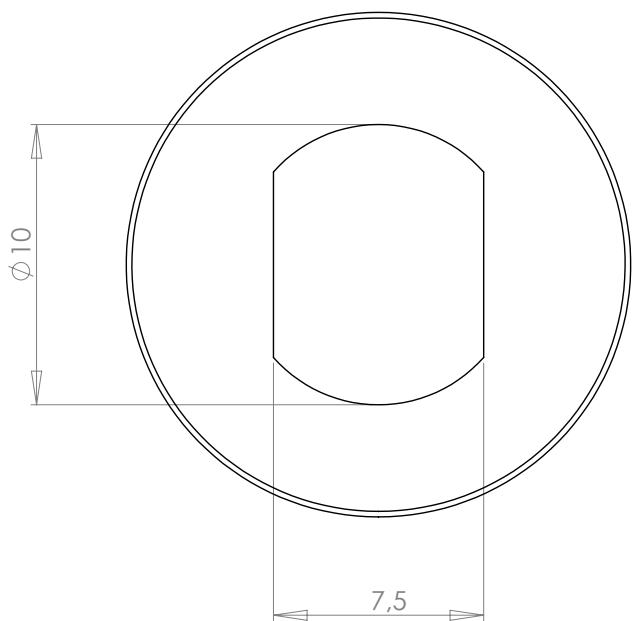
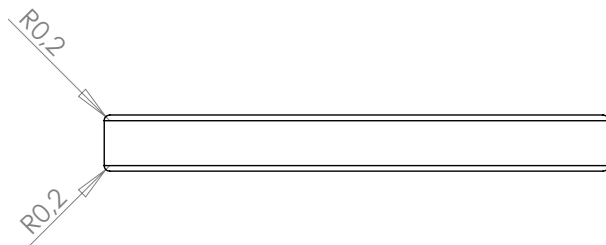
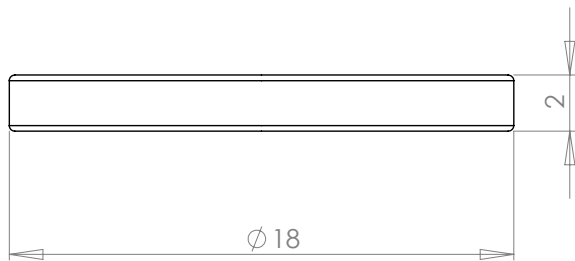
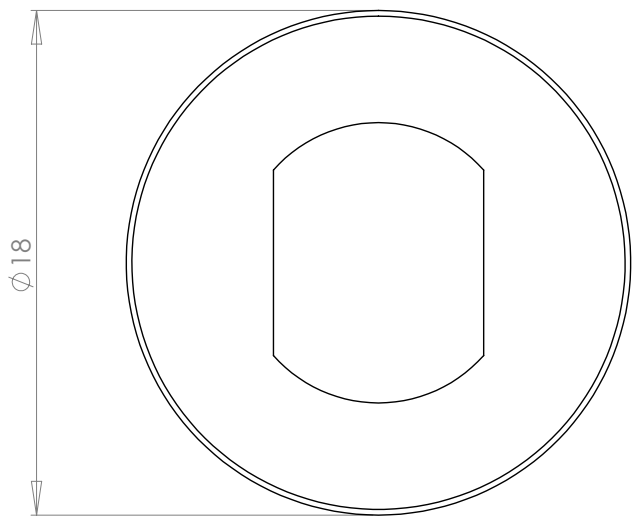

dcw.

Name : **BS RANGE**

Materials : NICKEL PLATED BRASS

Part : **BALL JOINT WASHER**

Date :

Rev : **2**

Details :

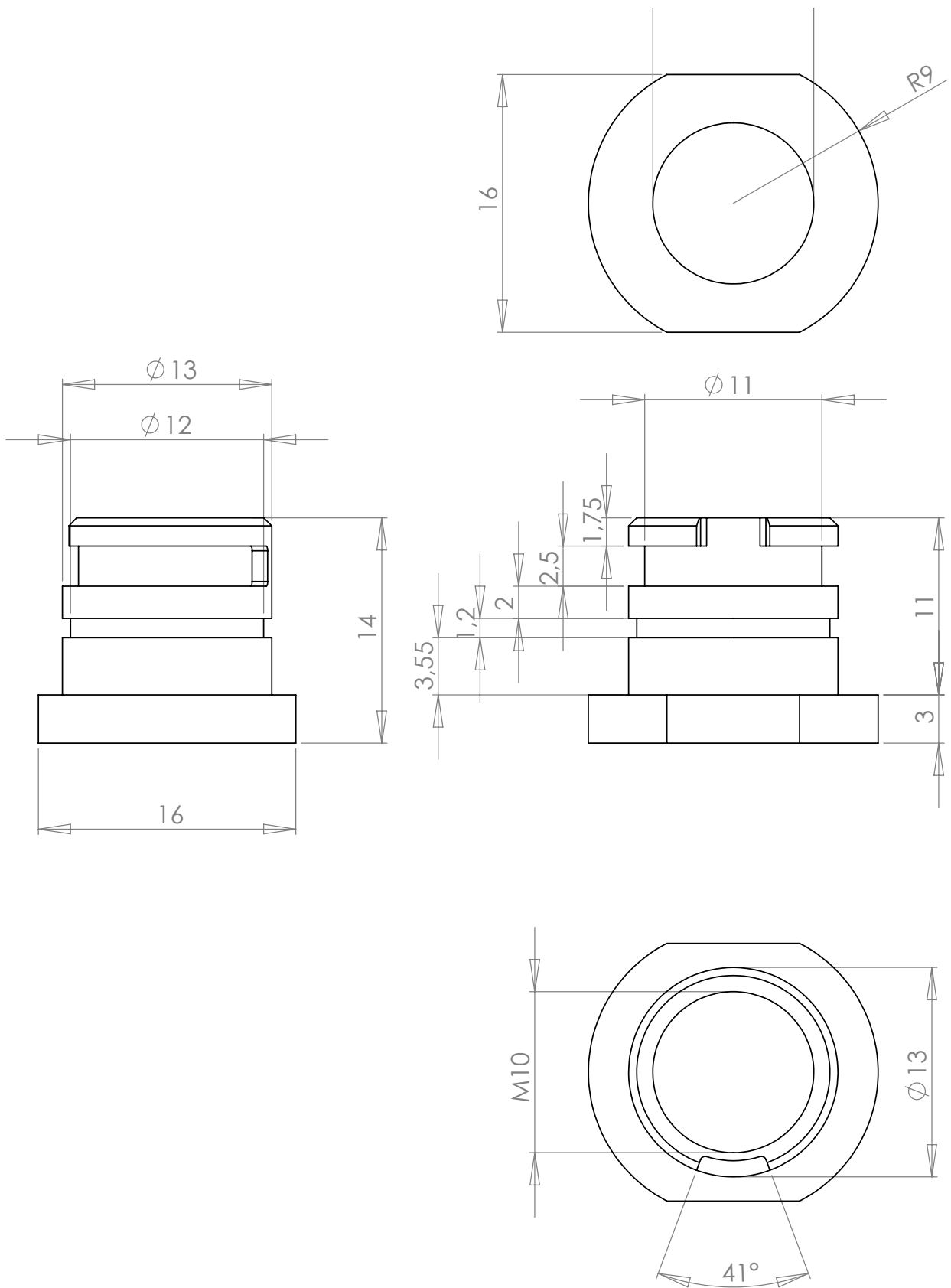

dcw.

Name : **BS RANGE**

Materials : NICKEL PLATED BRASS

Part : **BALL JOINT PART 5**

Date :

Rev : **2**

Details :

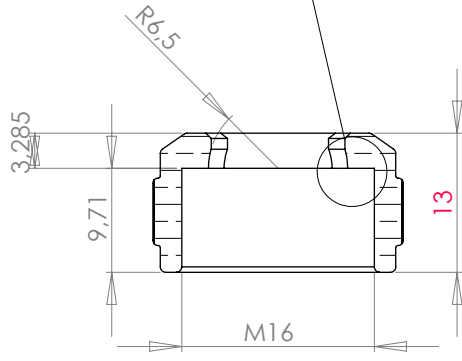
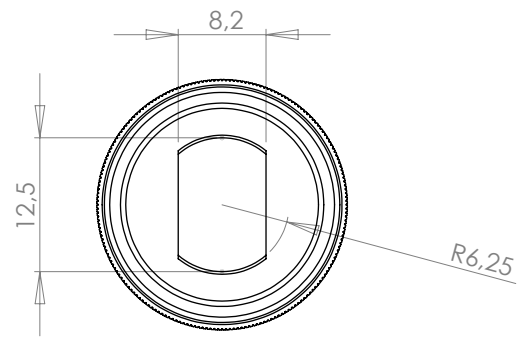
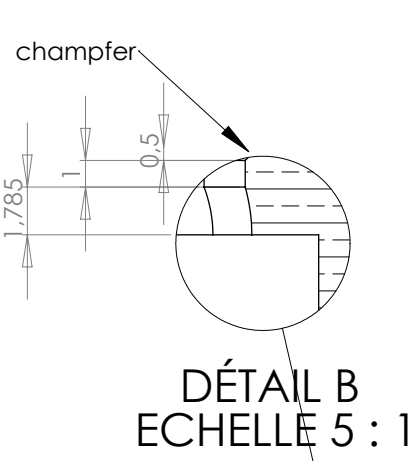

COUPE A-A

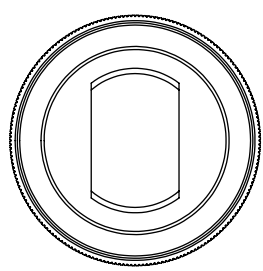
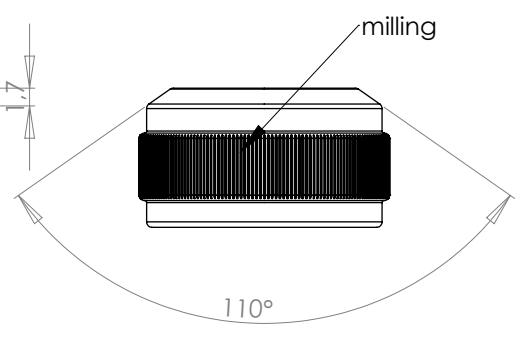
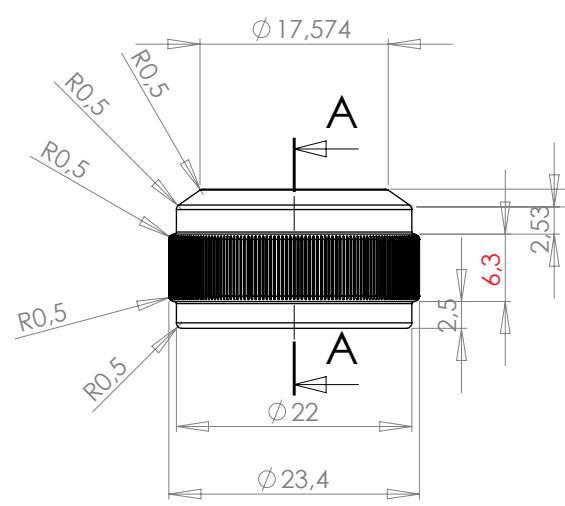

Name : **BS RANGE**

Materials : NICKEL PLATED BRASS

Part : **BALL JOINT PART 4**

Date :

Rev : **4**

Details :

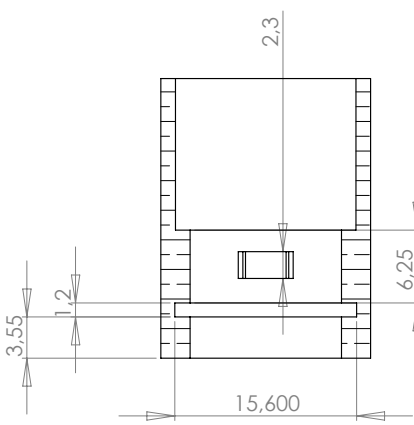
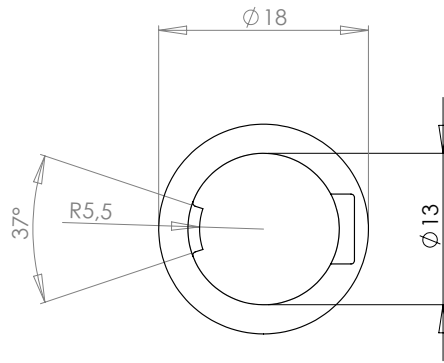

COUPE B-B

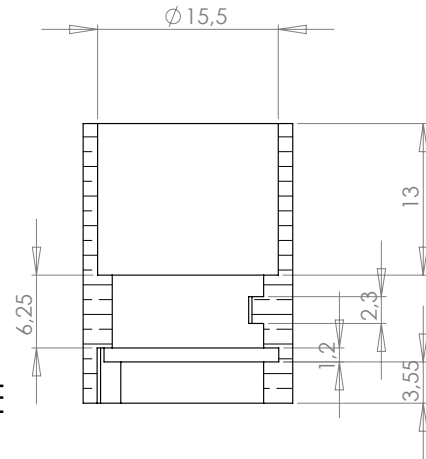
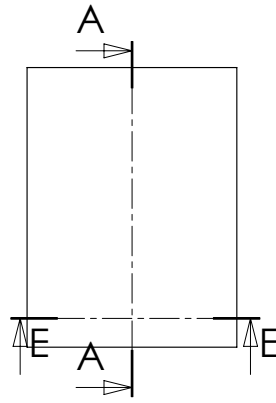
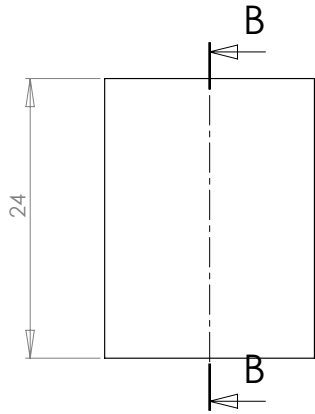

COUPE A-A

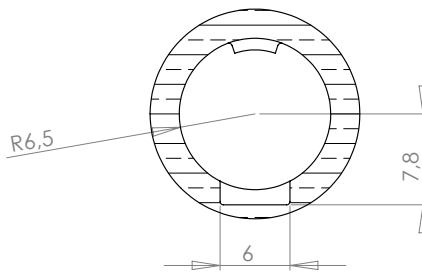

COUPE E-E

dcw.

Name : **BS RANGE**

Matériaux : NICKEL PLATED BRASS

Part : **BALL JOINT PART 3**

Date :

Rev : **3**

Details :

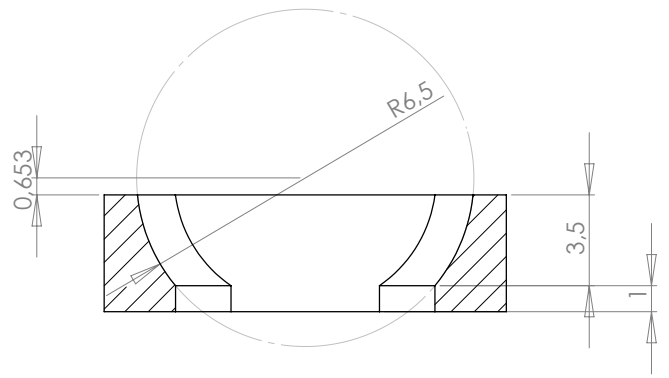
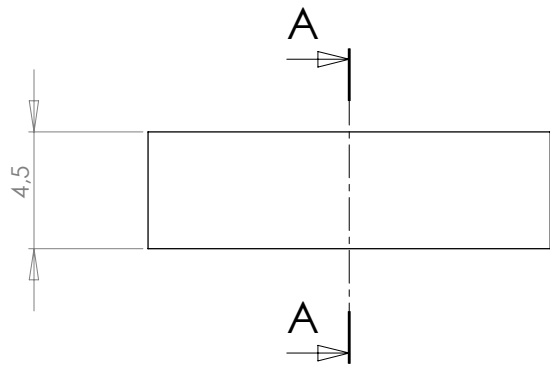
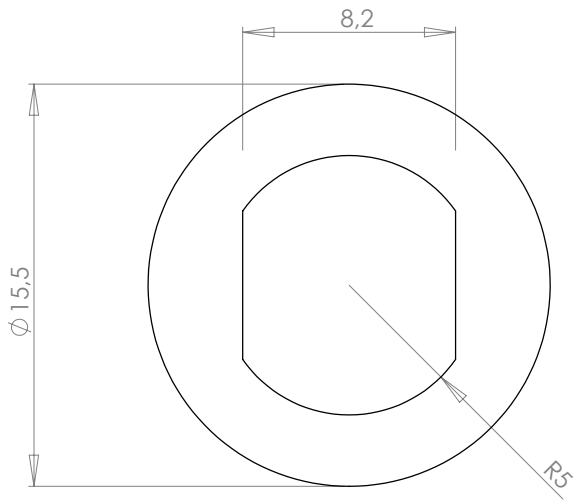

COUPE A-A

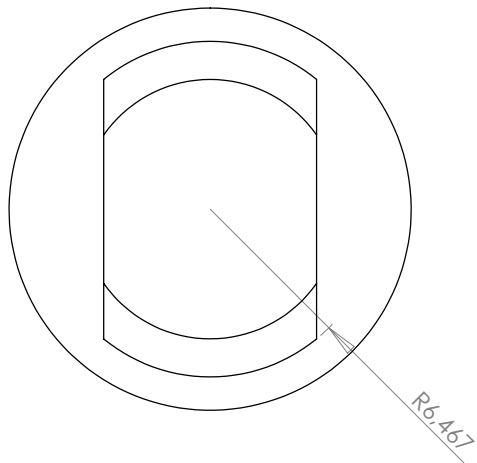

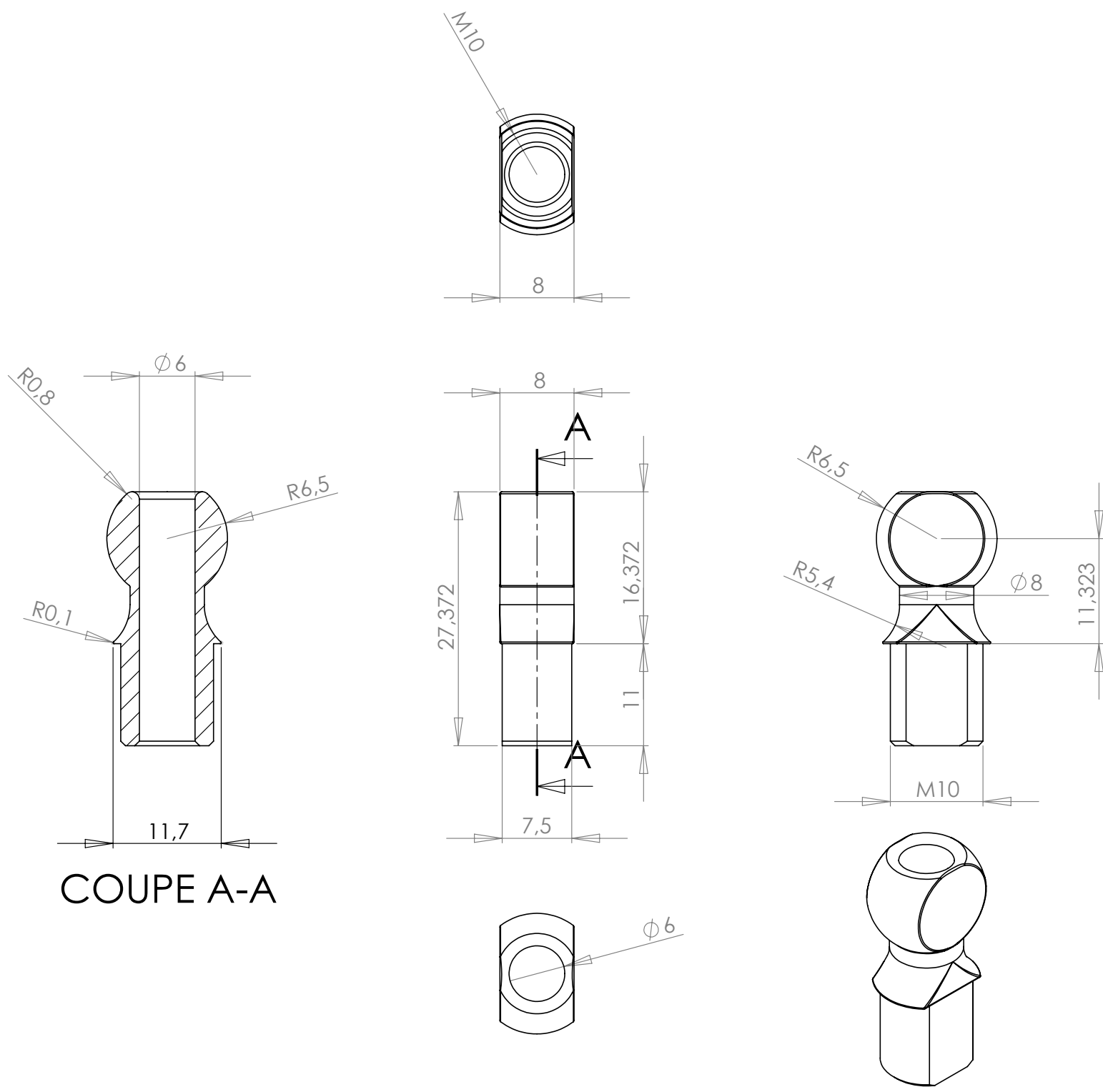

dcw.

Name : **BS RANGE**

Materials : NICKEL PLATED BRASS

Part : **BALL JOINT PART 1**

Date :

Rev : **2**

Details :

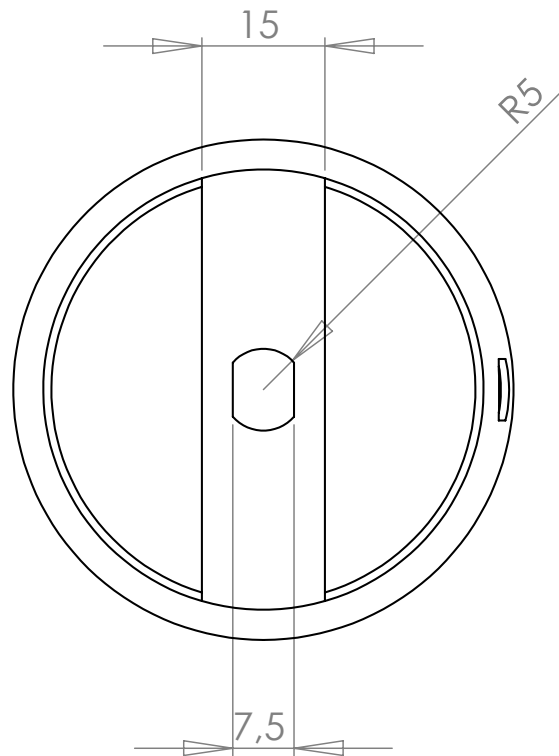
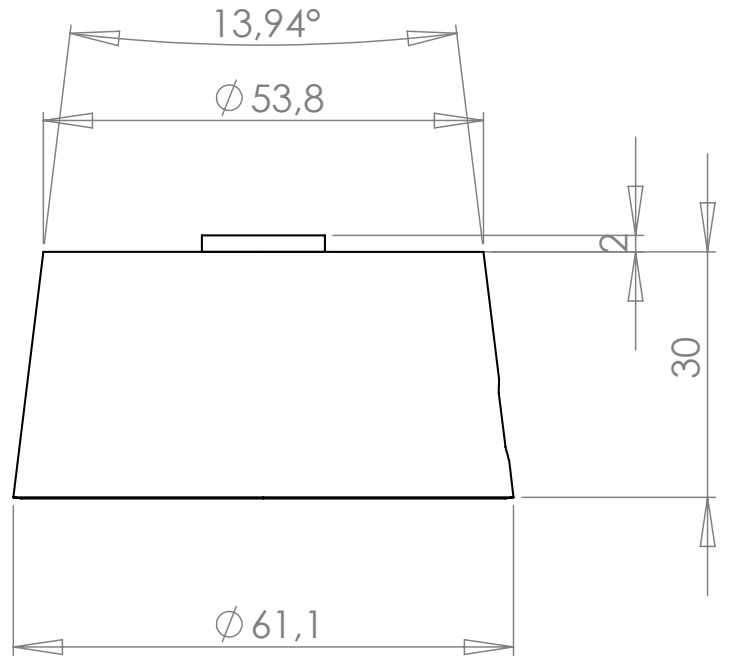
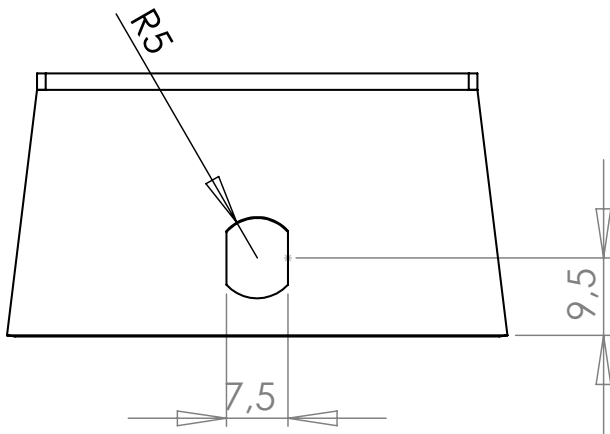

dcw.

Name : **BS1 FLOOR & BS2 WALL**

Materials : PAINTED STEEL

Part : **JUNCTION PIECE**

Date :

Rev : 2

Details :

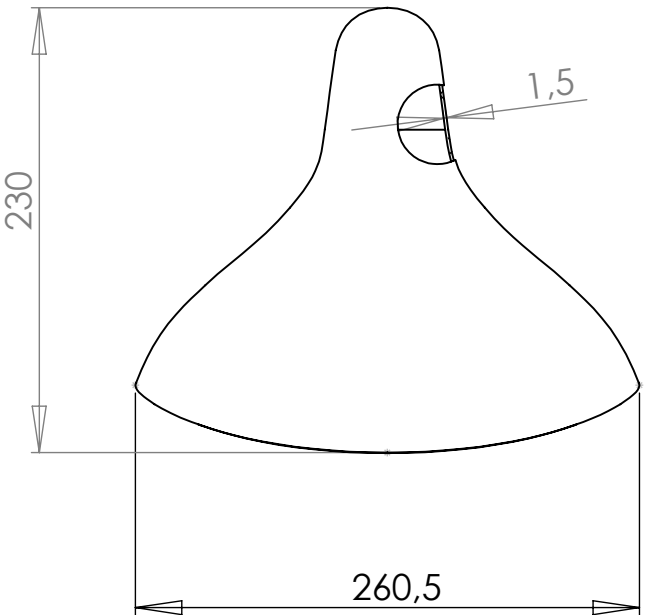
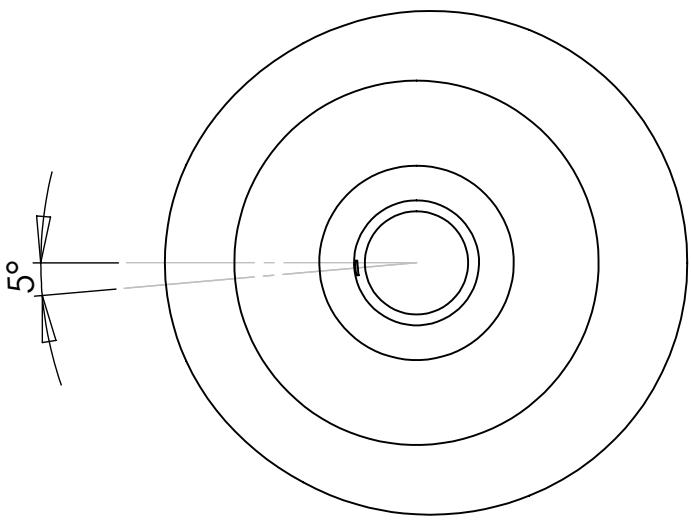
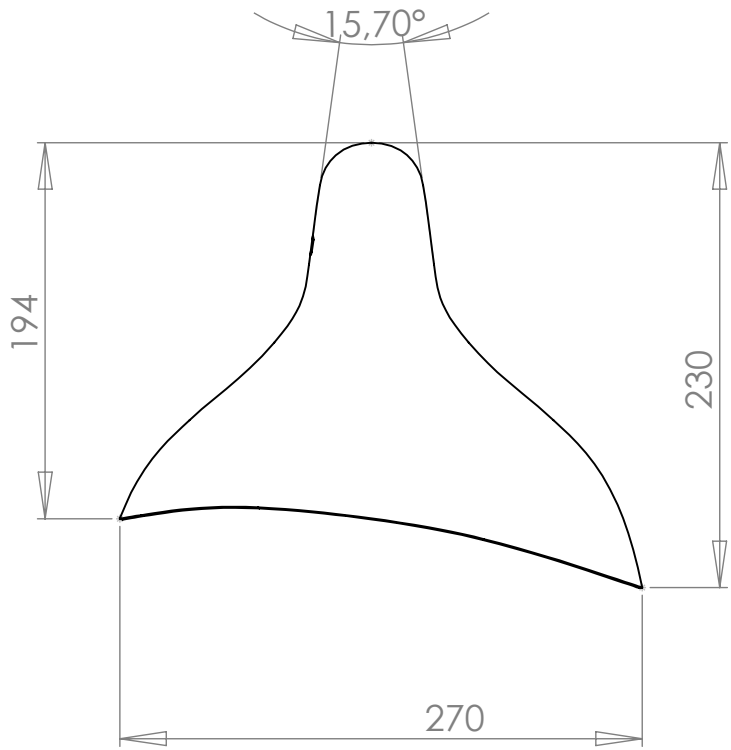
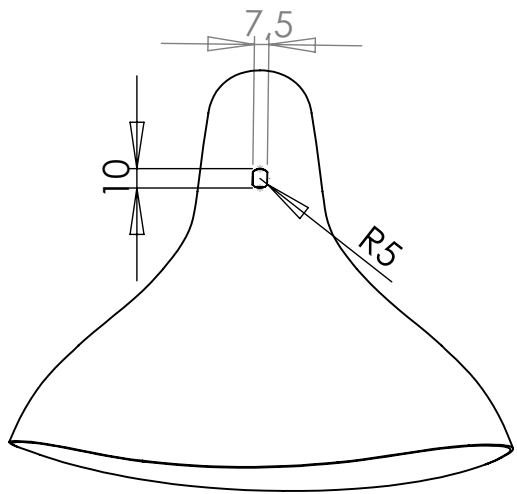

dcw.

Name : BS1 FLOOR & BS2 WALL

Materials : PAINTED ALUMINIUM

Part : SHADE

Date :

Rev : 3

Details :

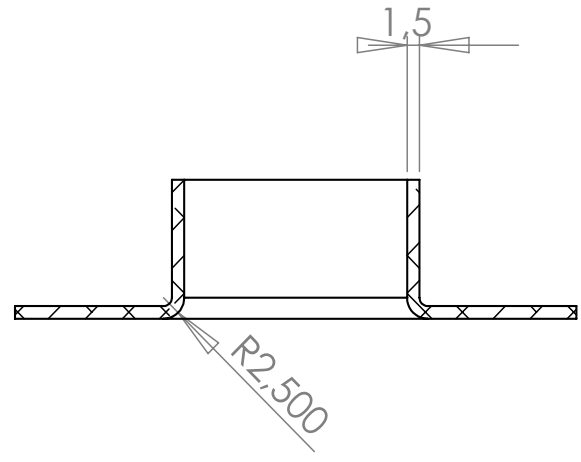
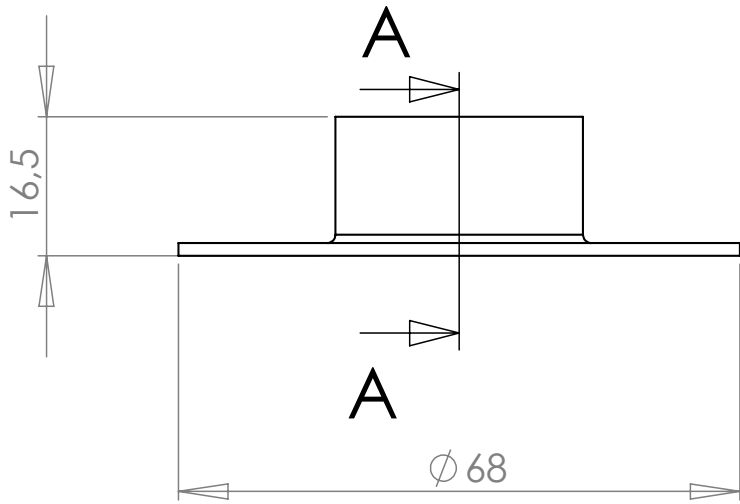

COUPE A-A

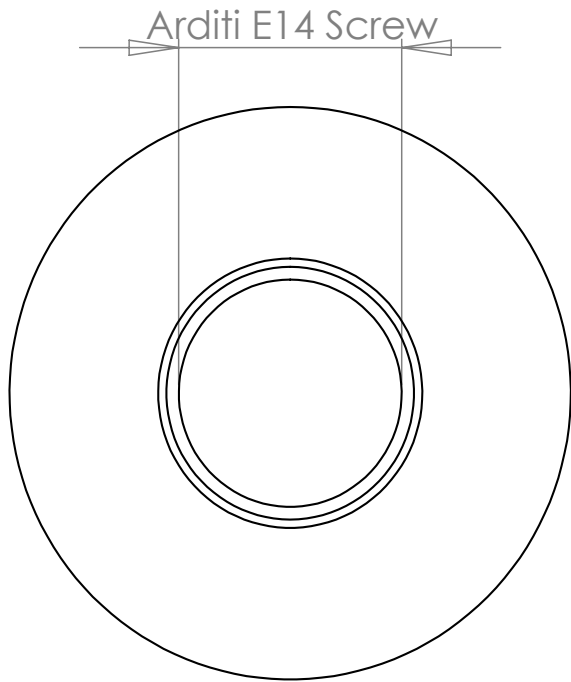

dcw.

Name : BS1 FLOOR & BS2 WALL

Matériaux : PAINTED STEEL

Part : COVER CUP

Date :

Rev : **2**

Details :