



| Qty | Piece | Finishing | | | |
|-----|------------------|---|---|------------------|-------------|
| 1 | BASE | MAT PAINTING - PANTONE 5635U | 1 | COVER CUP | MAT WHITE |
| 1 | TUBE BASE | MAT PAINTING - PANTONE 5635U | 1 | THREAD 10x100 | |
| 1 | PIVOT WASHER | BLACK | 1 | BULBHOLDER | |
| 1 | PIVOT LOCK PIECE | MAT PAINTING - PANTONE 5635U | 2 | M10 x 4 NUT | |
| 1 | PIVOT GUIDE | MAT PAINTING - PANTONE 5635U | 1 | M4 PLASTIC SCREW | |
| 1 | WEIGHT | MAT PAINTING - PANTONE 5635U | 2 | PLASTIC TUBE | TRANSPARENT |
| 1 | TUBE LOCK PIECE | MAT PAINTING - PANTONE 5635U | | | |
| 1 | BAR | MAT PAINTING - PANTONE 5635U | | | |
| 1 | CORD GRIPP 2 | NICKELED N8 | | | |
| 1 | TUBE | MAT PAINTING - PANTONE 5635U | | | |
| 1 | CORD GRIPP | MAT PAINTING - PANTONE 5635U | | | |
| 1 | BALL JOINT | NICKELED N8 | | | |
| 1 | SHADE | SATIN BLACK BK11 OUTSIDE / MAT WHITE INSIDE | | | |
| 1 | JUNCTION PIECE | MAT WHITE | | | |

dcw.

Name : BS3 – GR–BL

Materials :

Part : Finishings

Date : Rev : 2 Details : E14 - ESL 11W



| Qty | Piece | Finishing | | | |
|-----|------------------|--------------------------------------|---|------------------|-------------|
| 1 | BASE | MAT BLACK | 1 | COVER CUP | MAT WHITE |
| 1 | TUBE BASE | MAT BLACK | 1 | THREAD 10x100 | |
| 1 | PIVOT WASHER | BLACK | 1 | BULBHOLDER | |
| 1 | PIVOT LOCK PIECE | MAT BLACK | 2 | M10 x 4 NUT | |
| 1 | PIVOT GUIDE | MAT BLACK | 1 | M4 PLASTIC SCREW | TRANSPARENT |
| 1 | WEIGHT | MAT BLACK | 1 | PLASTIC TUBE | |
| 1 | TUBE LOCK PIECE | MAT BLACK | | | |
| 1 | BAR | MAT BLACK | | | |
| 1 | CORD GRIPP 2 | NICKELED N8 | | | |
| 1 | TUBE | MAT BLACK | | | |
| 1 | CORD GRIPP | MAT BLACK | | | |
| 1 | BALL JOINT | NICKELED N8 | | | |
| 1 | SHADE | MAT BLACK OUTSIDE / MAT WHITE INSIDE | | | |
| 1 | JUNCTION PIECE | MAT WHITE | | | |

dcw.

Name : **BS3 – BL**

Matériaux :

Part : **Finishings**

Date :

Rev : 2

Details : E14 - ESL 11W

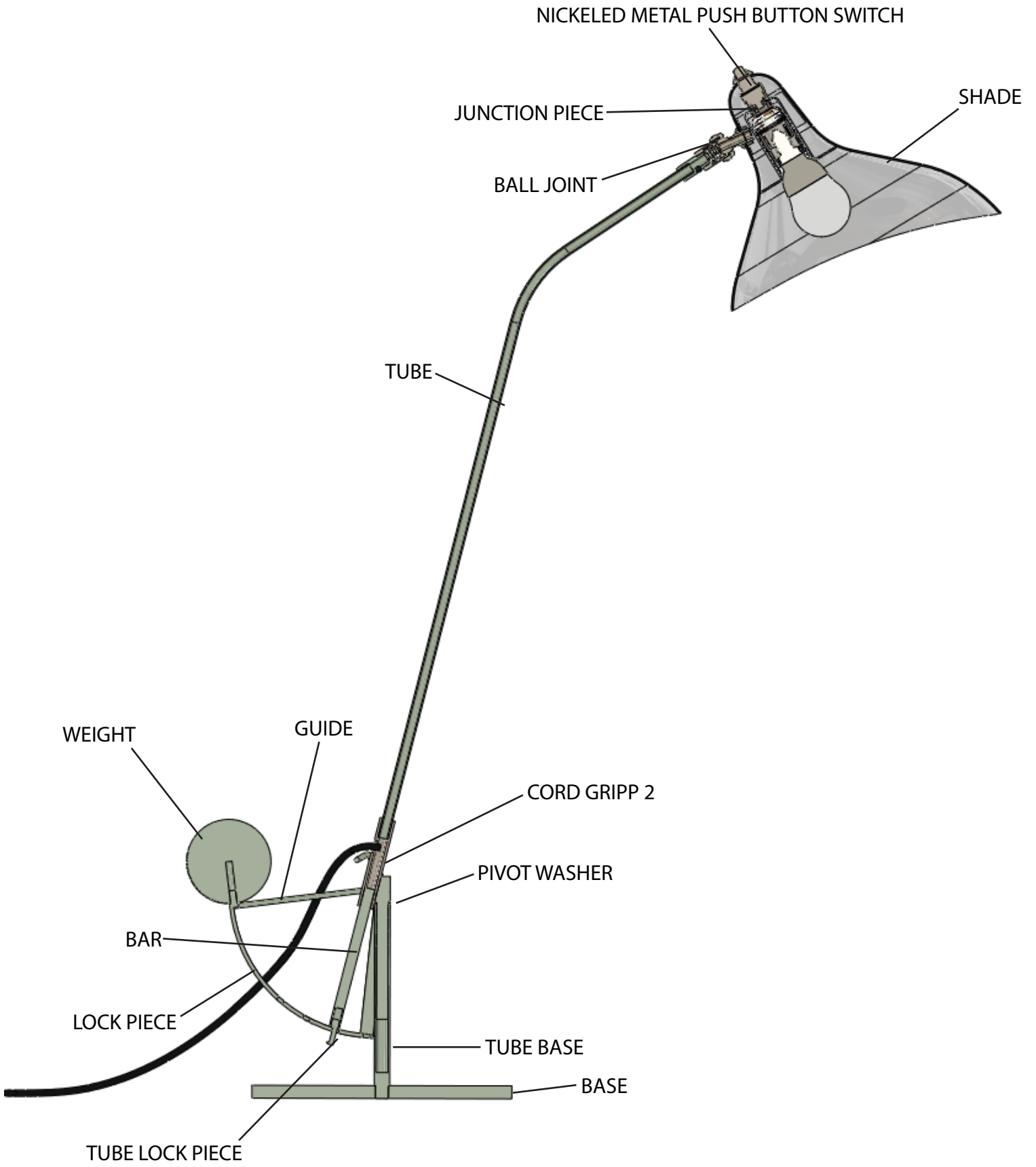

dcw.

Name : **BS3 TABLE**

Materials :

Part : **ELEMENTS**

Date :

Rev : 2

Details :

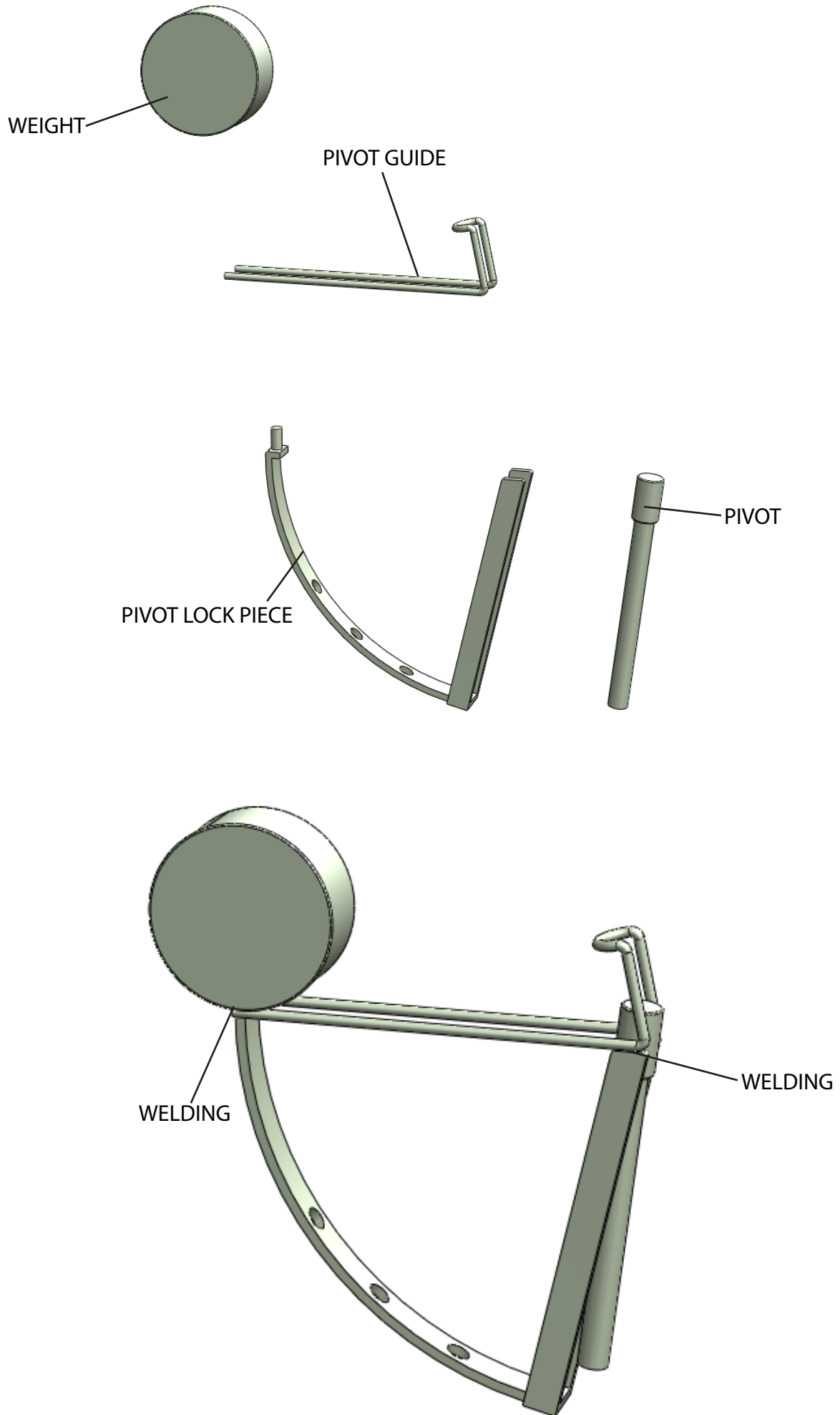

dcw.

Name : **BS3 TABLE**

Part : **WEIGHT SYSTEM DETAILS**

Date :

Rev : 2

Materials :

Details :

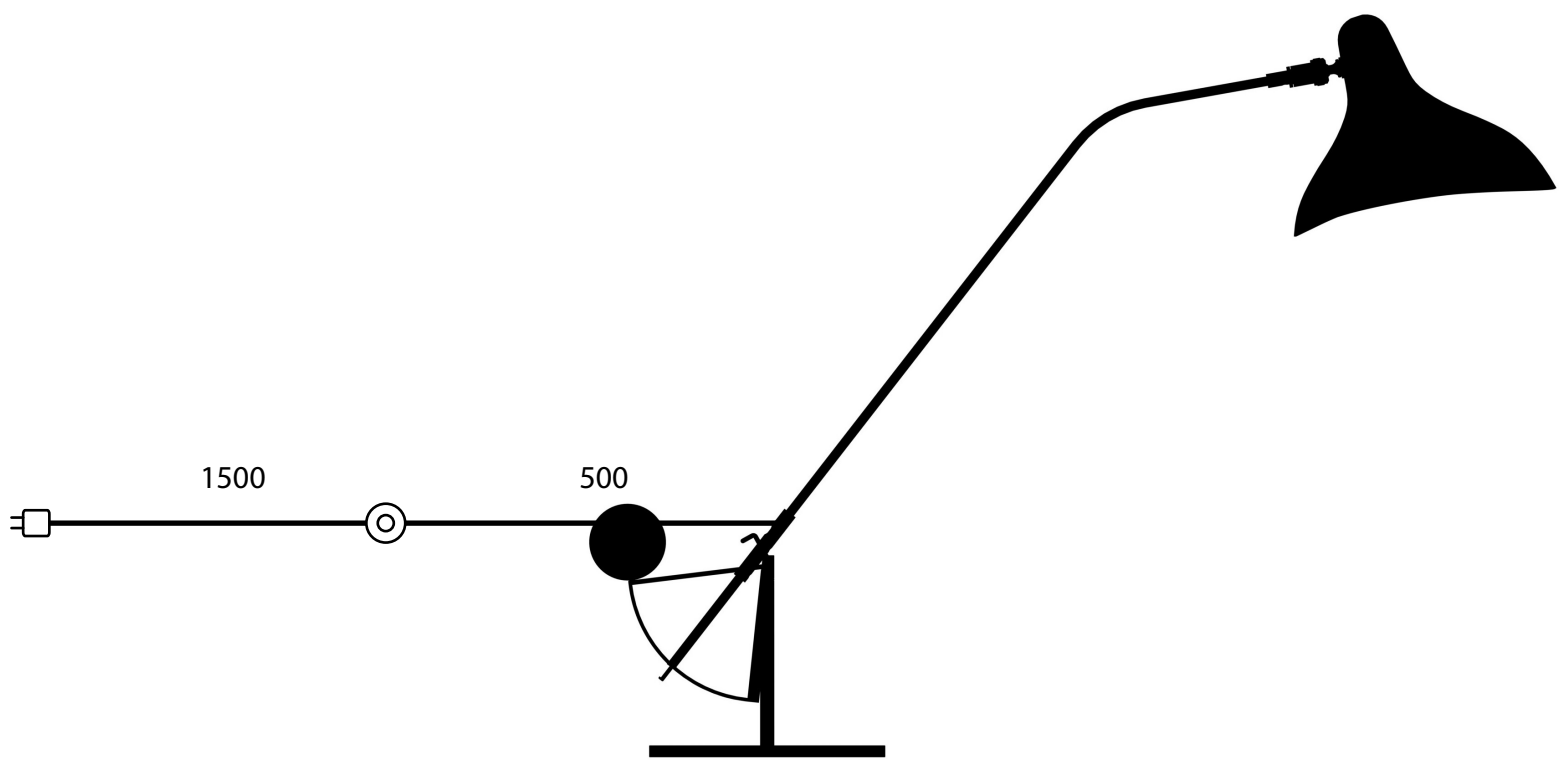

dcw.

Name : **BS3 TABLE**

Part : **ELEC LENGHT**

Date :

Rev : 2

Matérials :

Details :

Be careful : This piece must be done by machining

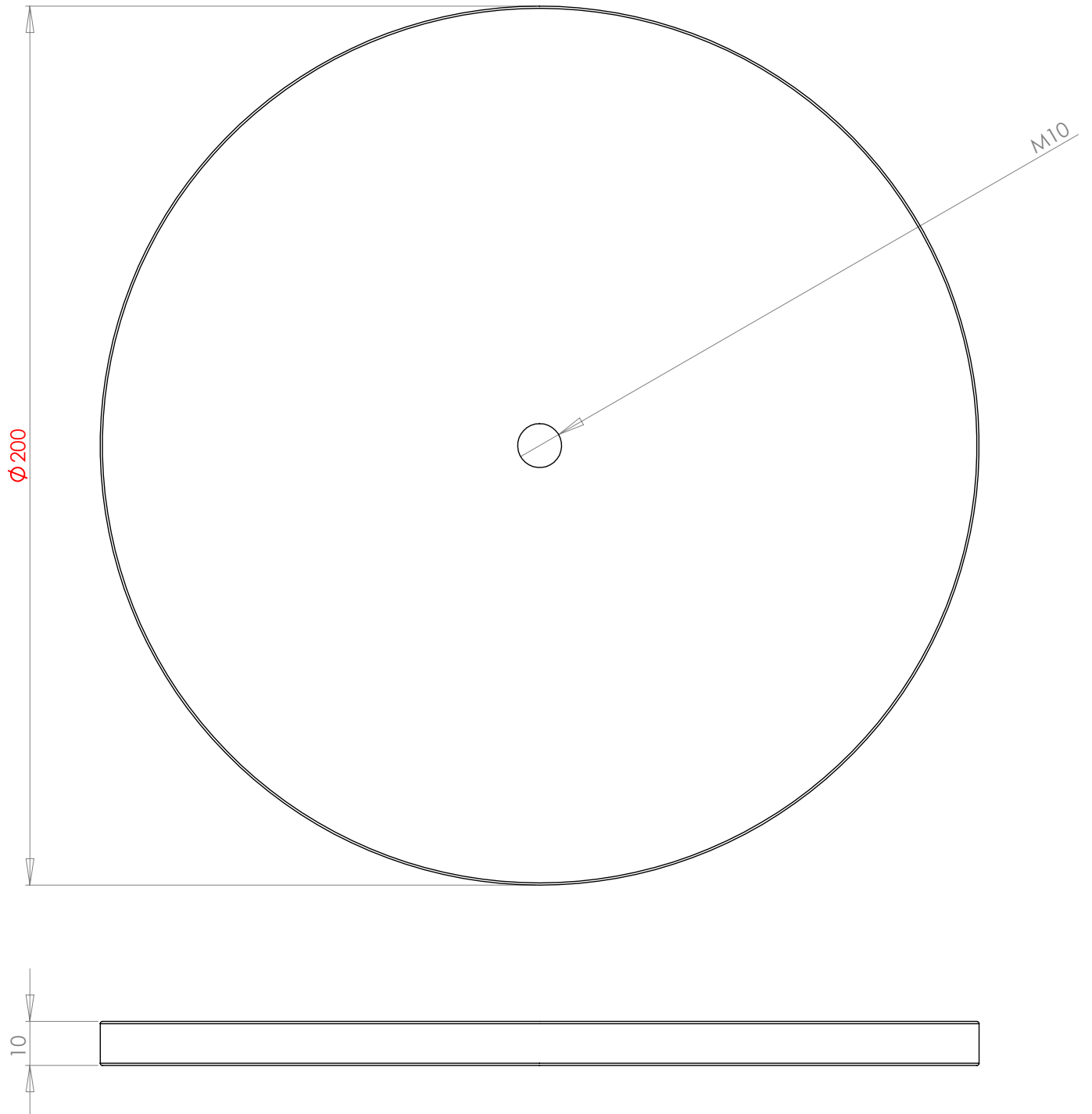

dcw.

Name : **BS3 TABLE**

Materials : PAINTED STEEL

Part : **BASE**

Date :

Rev : 2

Details :

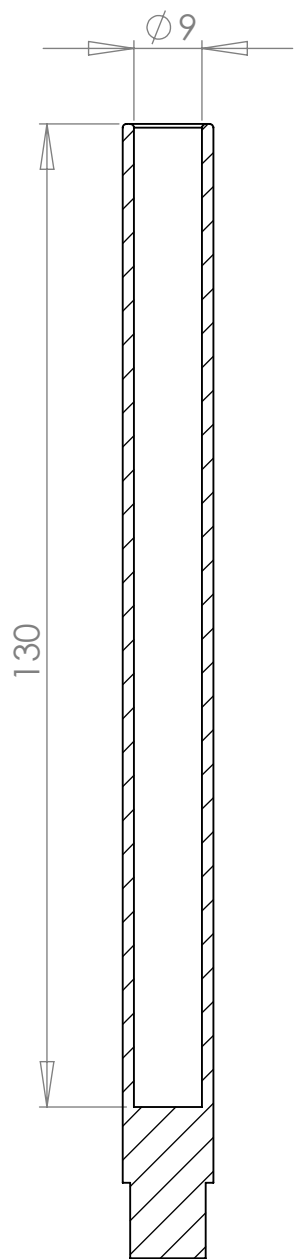

COUPE A-A

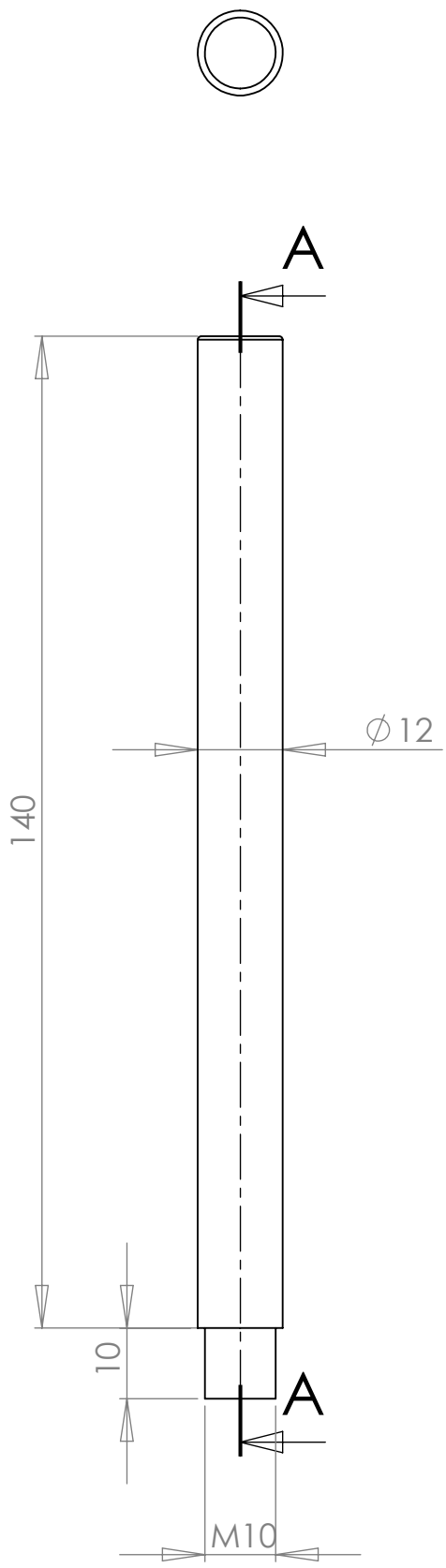

dcw.

Name : **BS3 TABLE**

Materials : PAINTED STEEL

Part : **TUBE BASE**

Date :

Rev : 1

Details :

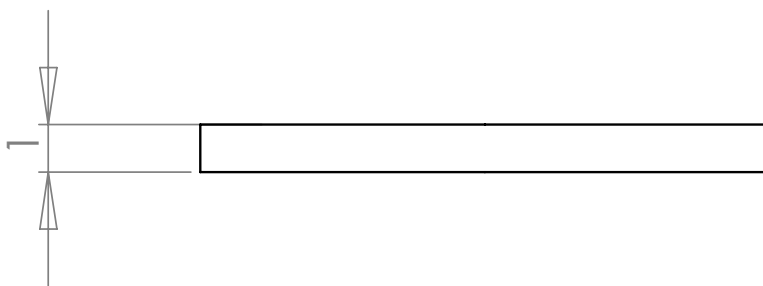
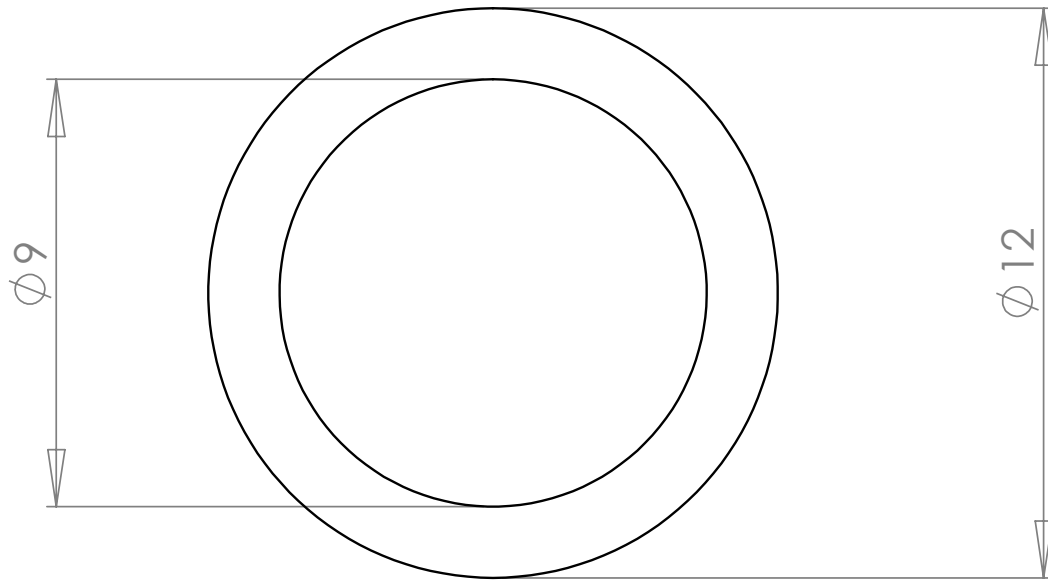

dcw.

Name : **BS1 FLOOR & BS3 TABLE**

Matériaux : PLASTIC

Part : **PIVOT WASHER**

Date :

Rev : 1

Details :

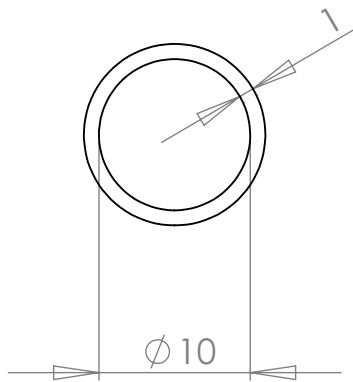
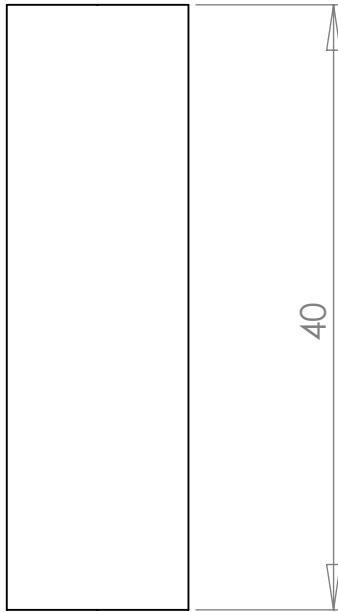

THIS PIECE WILL BE PACKED SEPARATELY

dcw.

Name : **BS1 FLOOR & BS3 TABLE**

Materials : TRANSPARENT PLASTIC

Part : **PLASTIC TUBE**

Date :

Rev : **1**

Details :

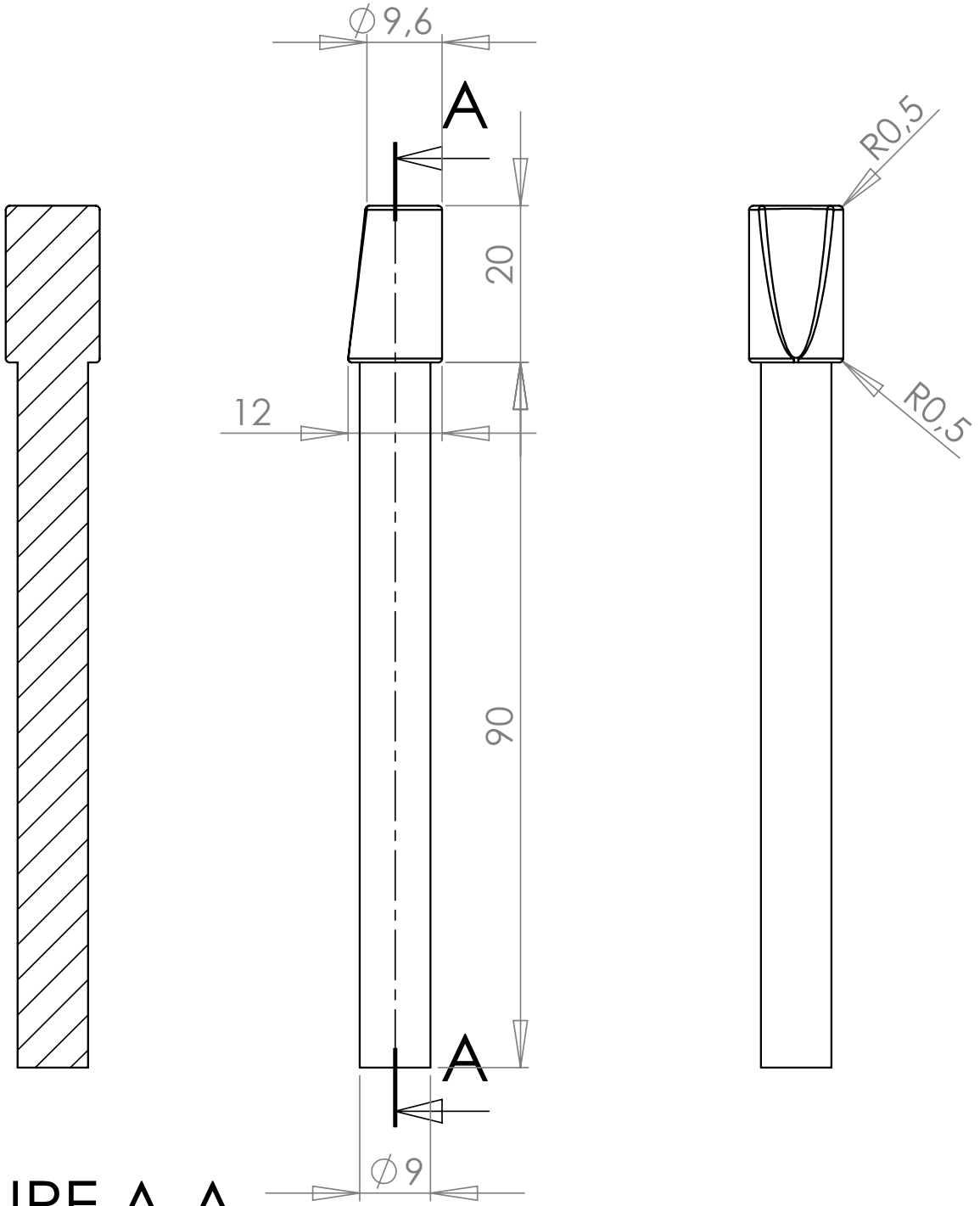

COUPE A-A

dcw.

| | | |
|---|---------|---------------------------|
| Name : BS1 FLOOR & BS3 TABLE | | Materials : PAINTED STEEL |
| Part : PIVOT | | |
| Date : | Rev : 2 | Details : |

B.SCHOTTLANDER | dcw.

Name : **BS3 TABLE**
Part : **PIVOT LOCK PIECE**
Date :

Rev : **3**

Materials : **PAINTED STEEL**
Details :

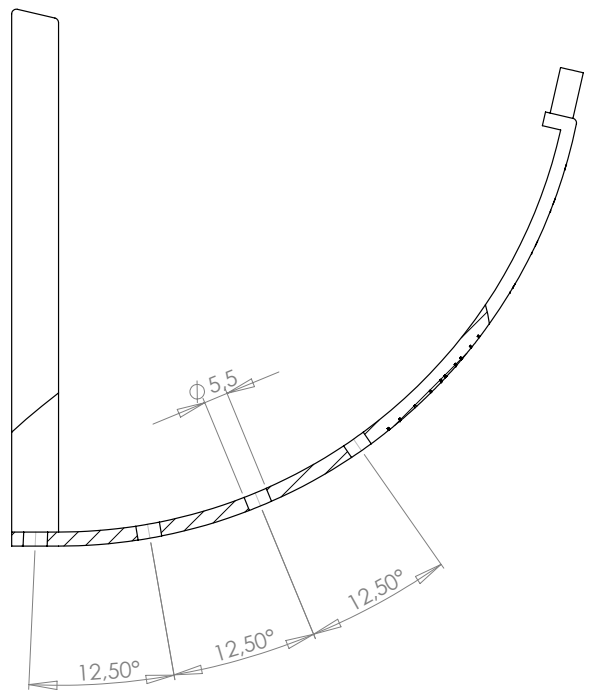
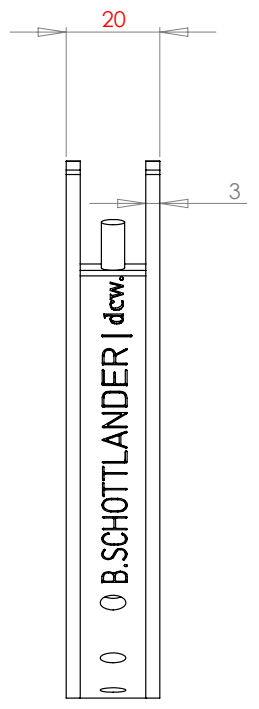
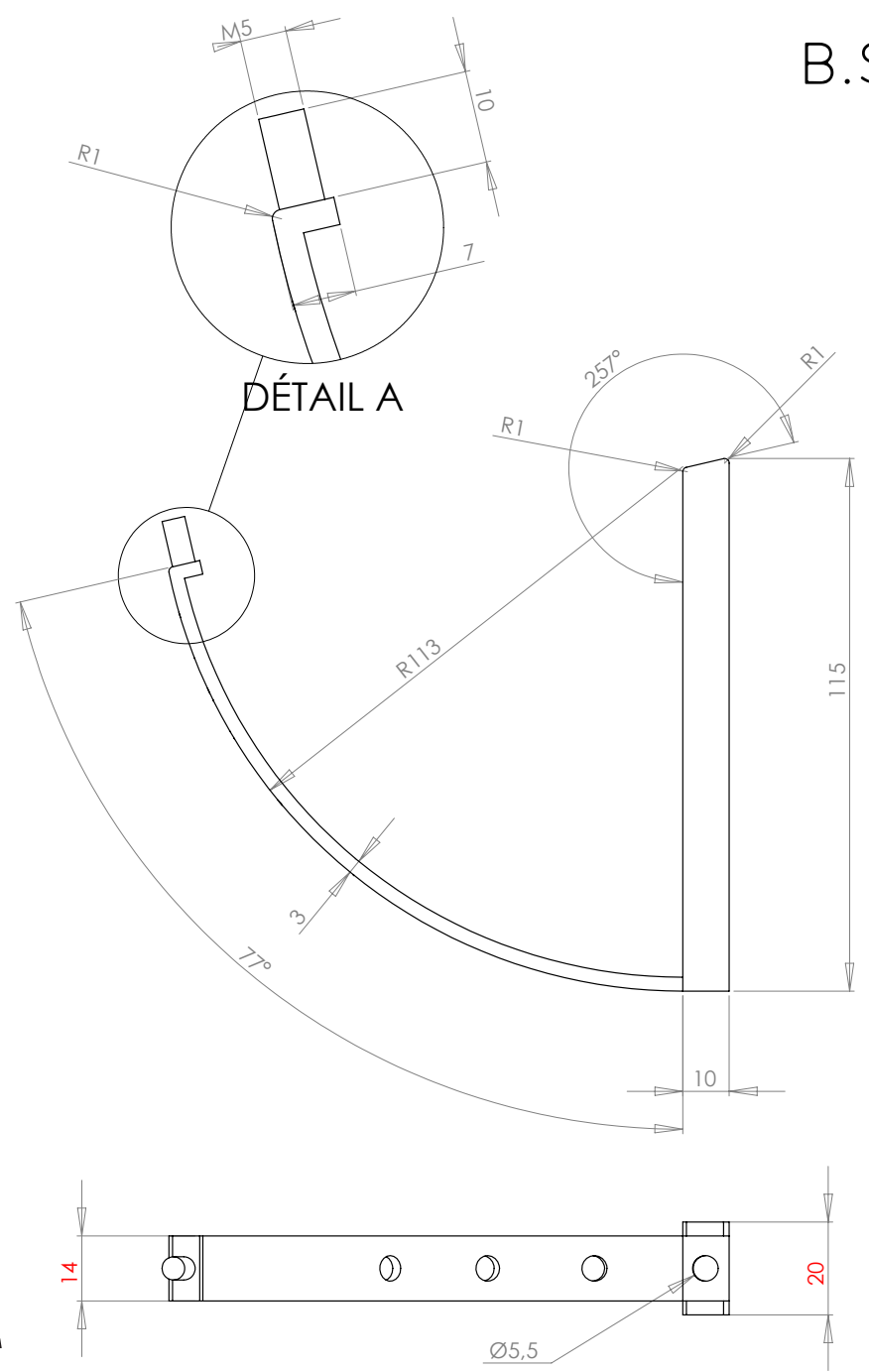

dcw.

Date :

Rev : 2

Details :

Part : PIVOT GUIDE

Name : BS3 TABLE

Materials : PAINTED STEEL

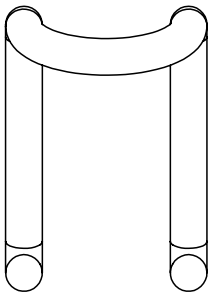
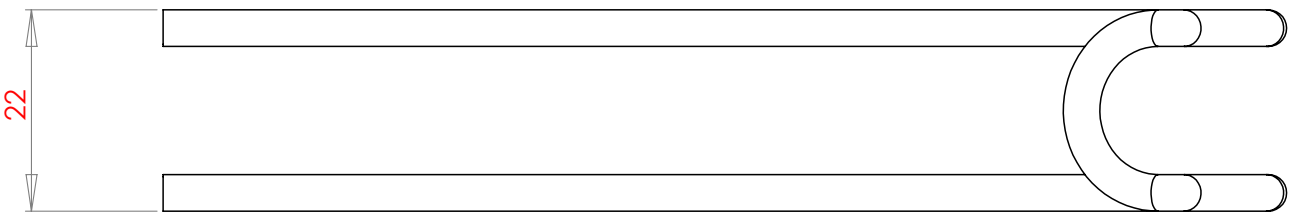
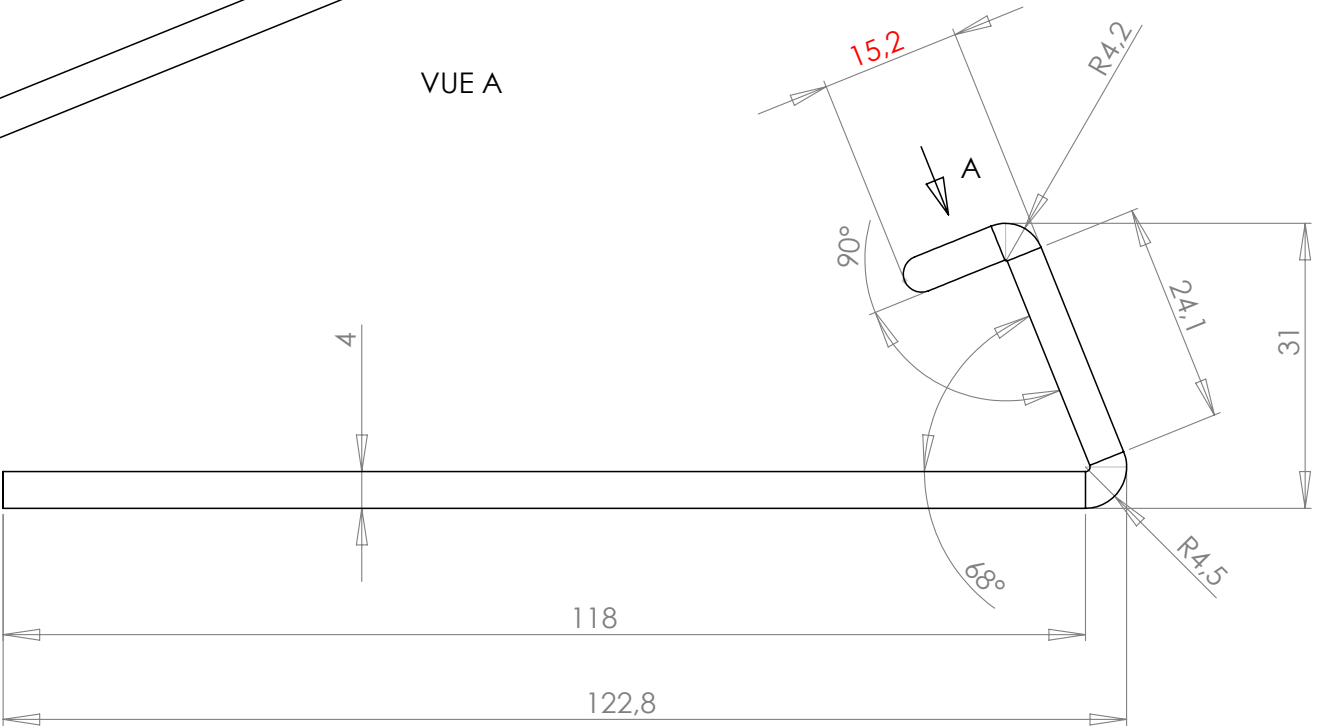
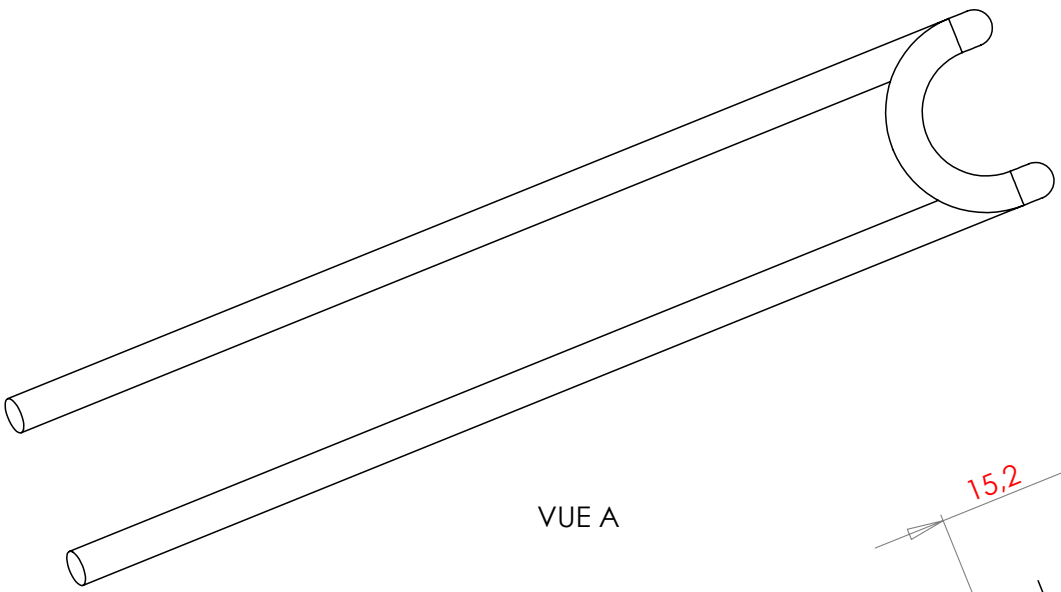

dcw.

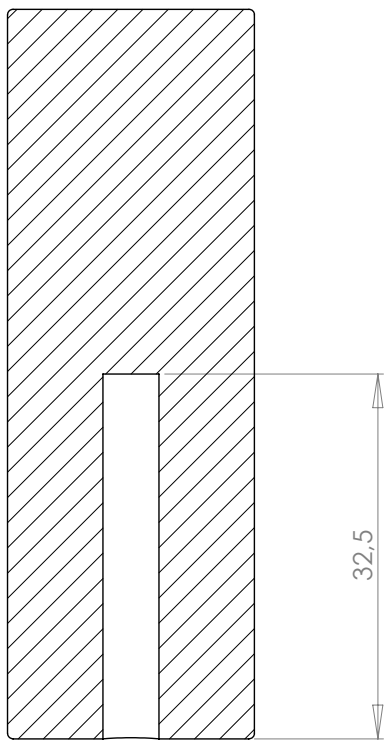
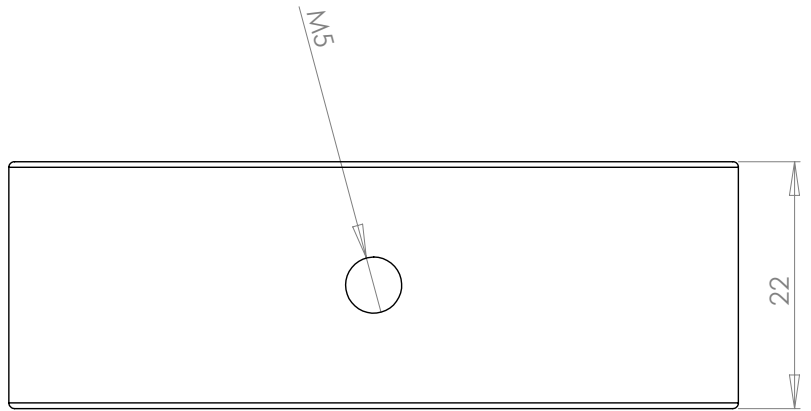

COUPE A-A

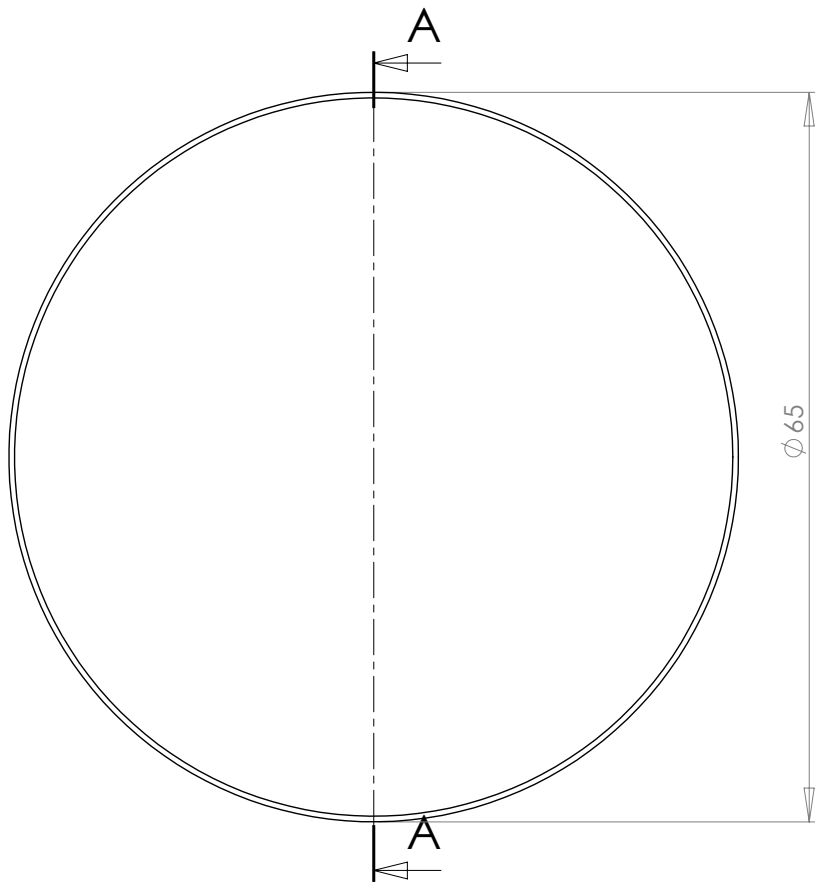

dcw.

Name : **BS3 TABLE**

Matériaux : PAINTED STEEL

Part : **WEIGHT**

Date :

Rev : **3**

Details :

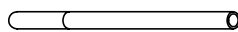
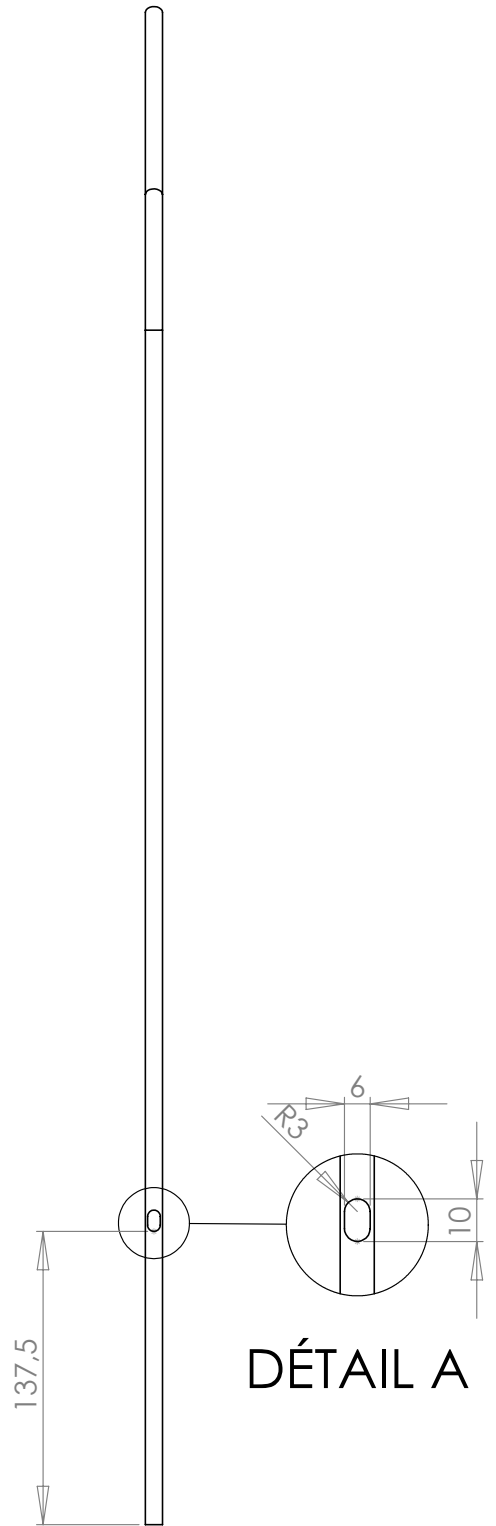
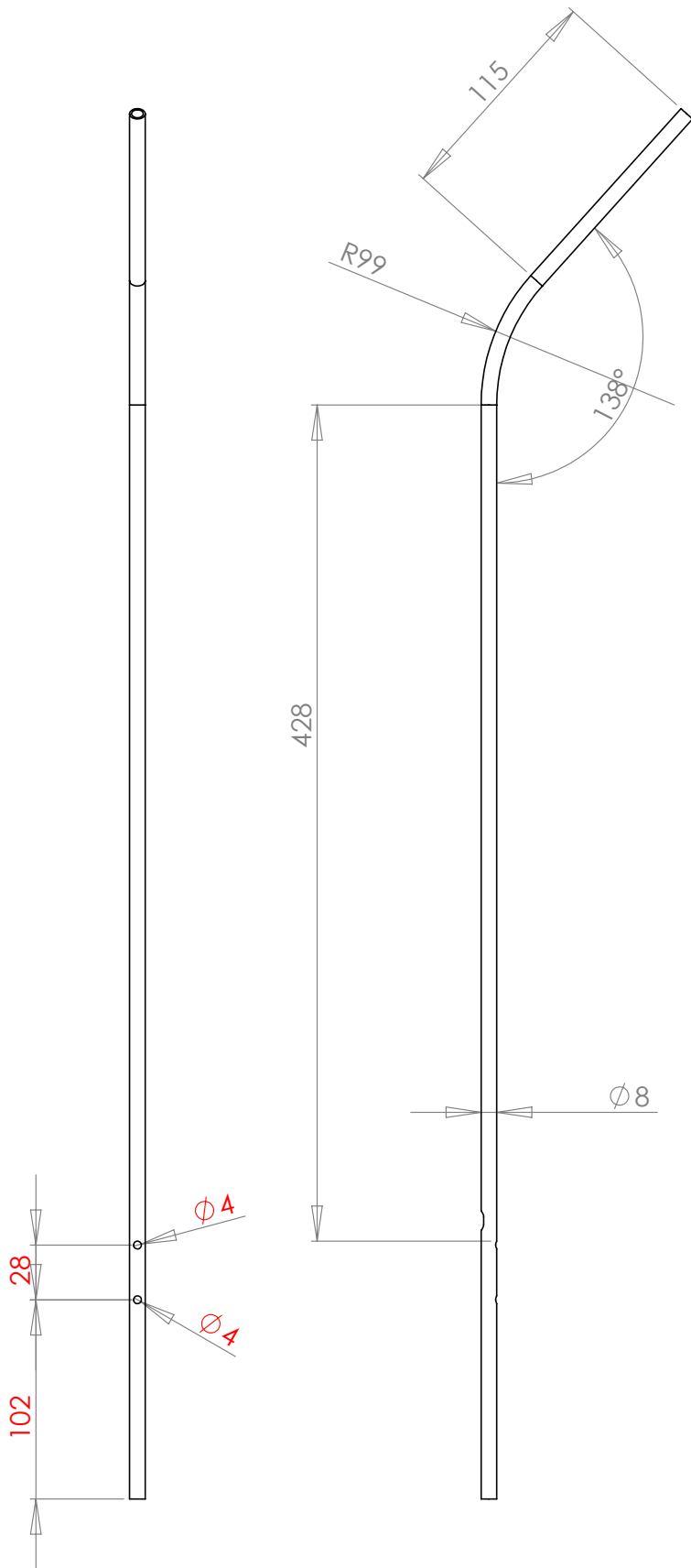

dcw.

Name : **BS3 TABLE**

Matériaux : PAINTED STEEL

Part : **TUBE**

Date :

Rev : **4**

Details :

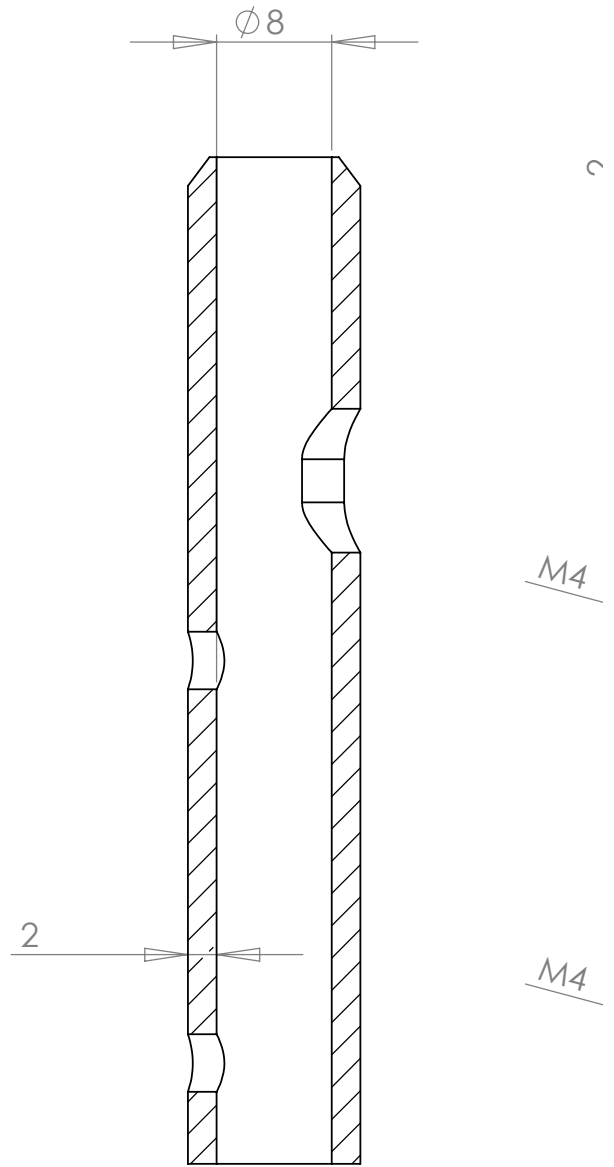
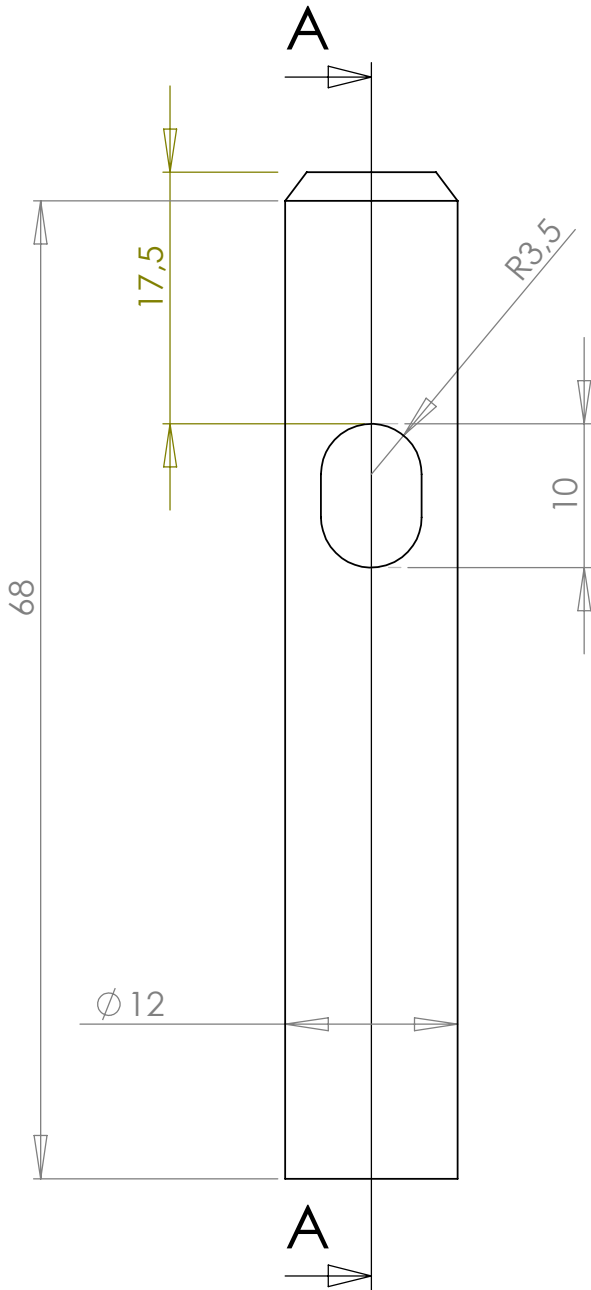
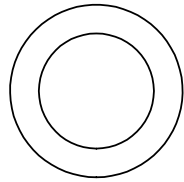

COUPE A-A

dcw.

Name : BS1 FLOOR & BS3 TABLE

Matériaux : NICKELÉD STEEL

Part : SLEEVE

Date :

Rev : **3**

Details :

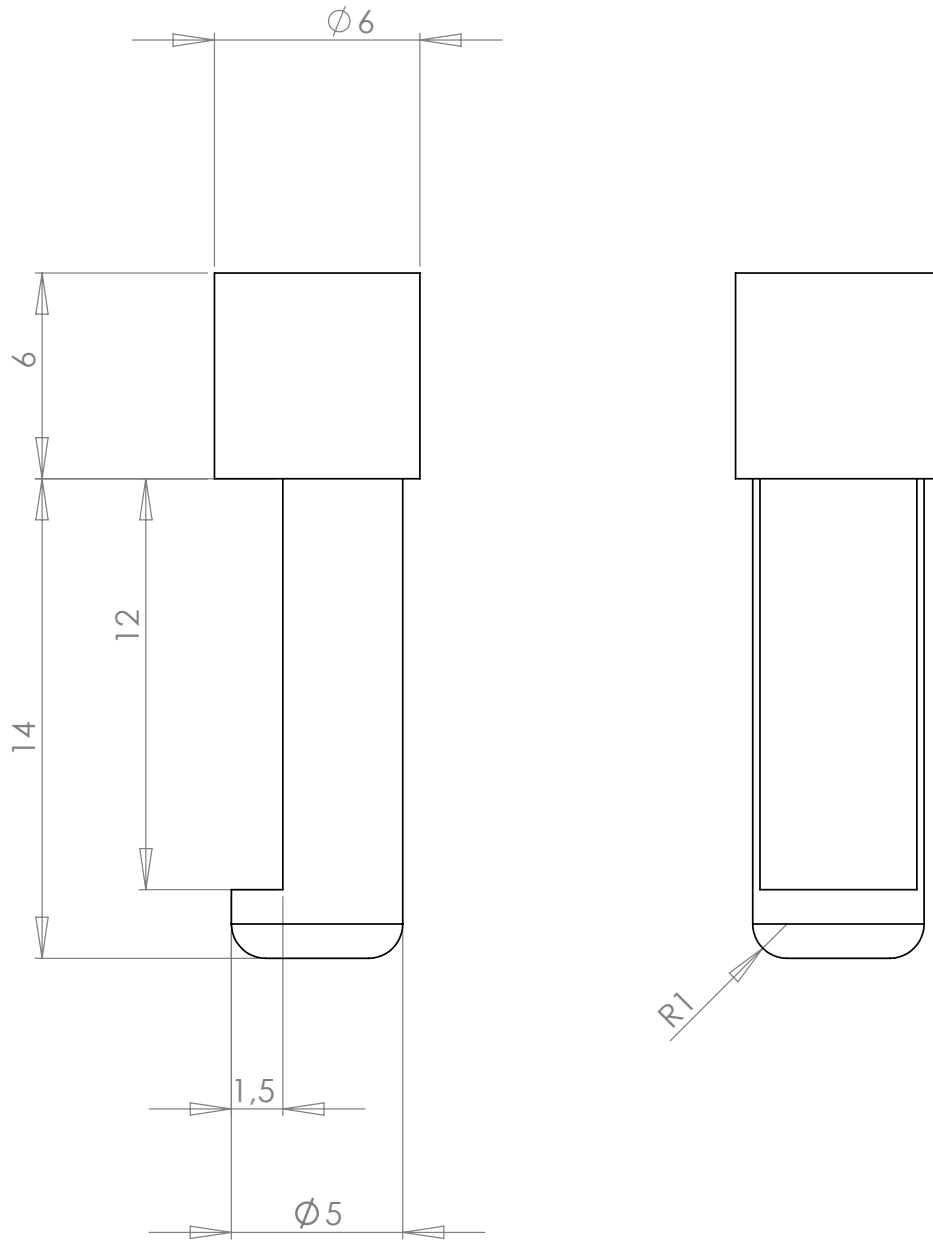

dcw.

Name : **BS1 FLOOR & BS3 TABLE**

Materials : PAINTED STEEL

Part : **TUBE LOCK PIECE**

Date :

Rev : 2

Details :

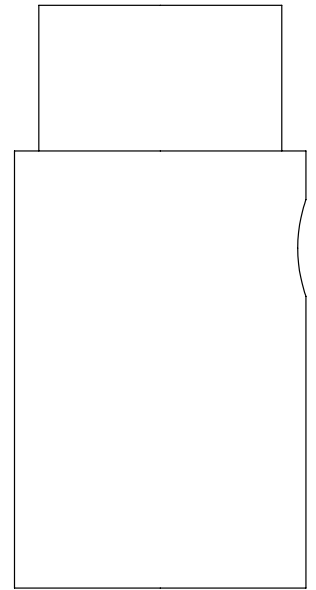
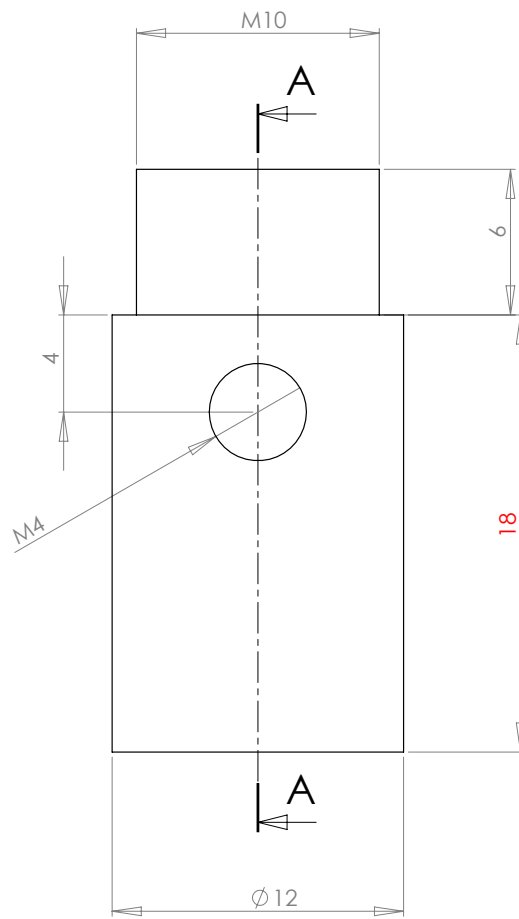
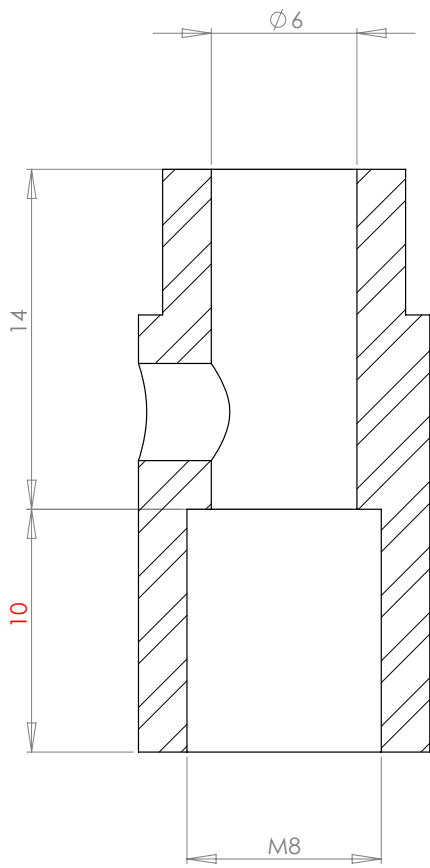

COUPE A-A

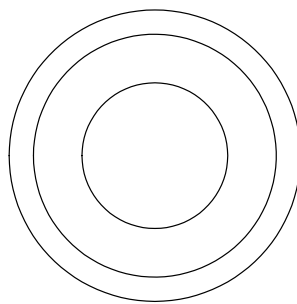

dcw.

Name : **BS RANGE**

Materials : PAINTED STEEL

Part : **CORD GRIPP**

Date :

Rev : 2

Details :

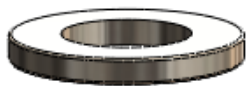

BALL JOINT WASHER



HEXAGON NUT M10x4

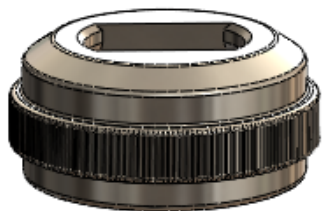

BALL JOINT PART 4

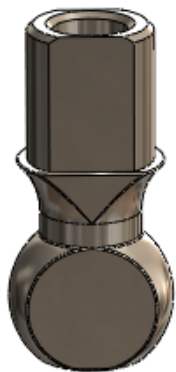
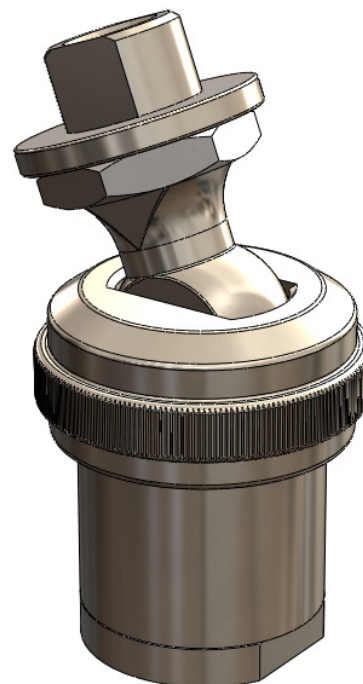

BALL JOINT PART 1

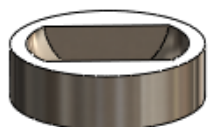

BALL JOINT PART 2



SPRING



BALL JOINT PART 3



CIRCLIP

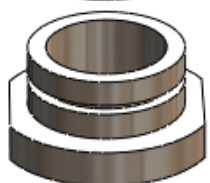

BALL JOINT PART 5

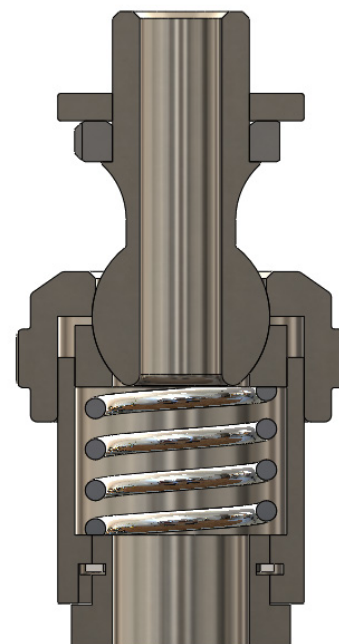
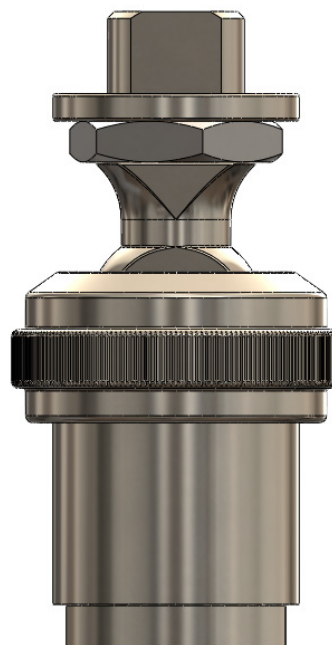

dcw.

Name : **BS RANGE**

Materials : NICKEL PLATED BRASS / PAINTED BRASS

Part : **BALL JOINT DETAILS**

Date :

Rev : **2**

Details :

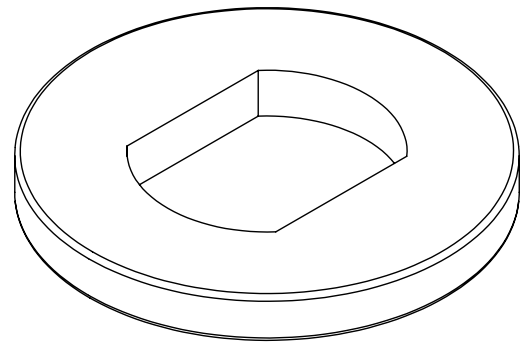
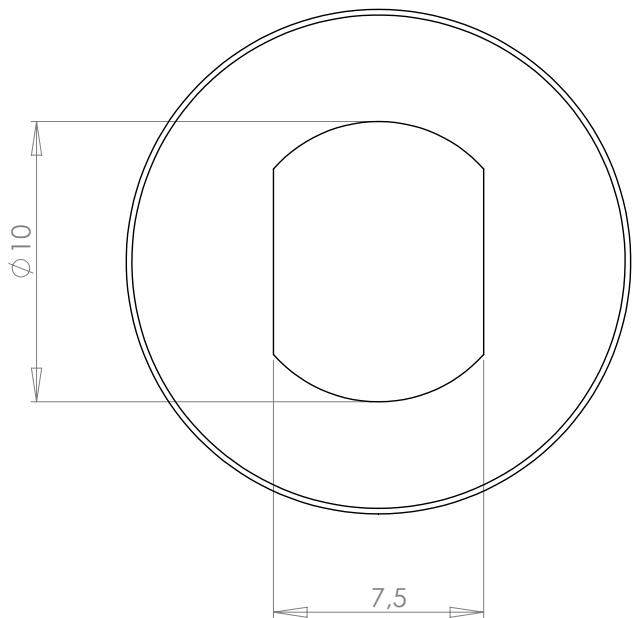
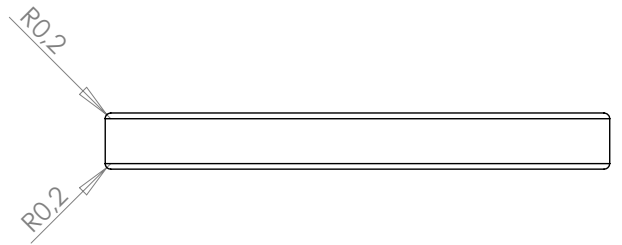
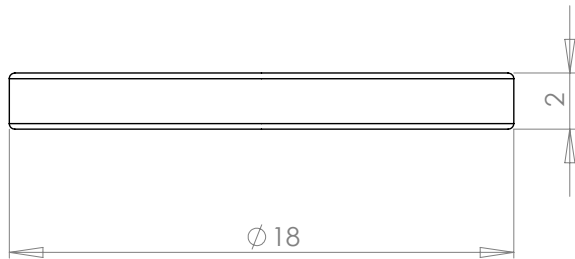
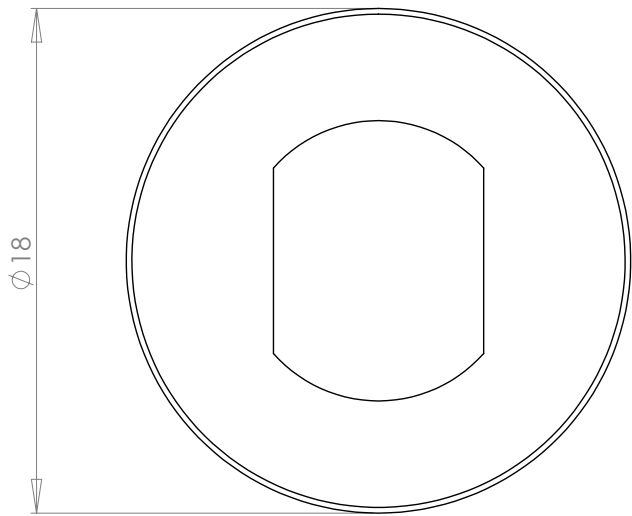

dcw.

Name : **BS RANGE**

Materials : NICKEL PLATED BRASS

Part : **BALL JOINT WASHER**

Date :

Rev : **2**

Details :

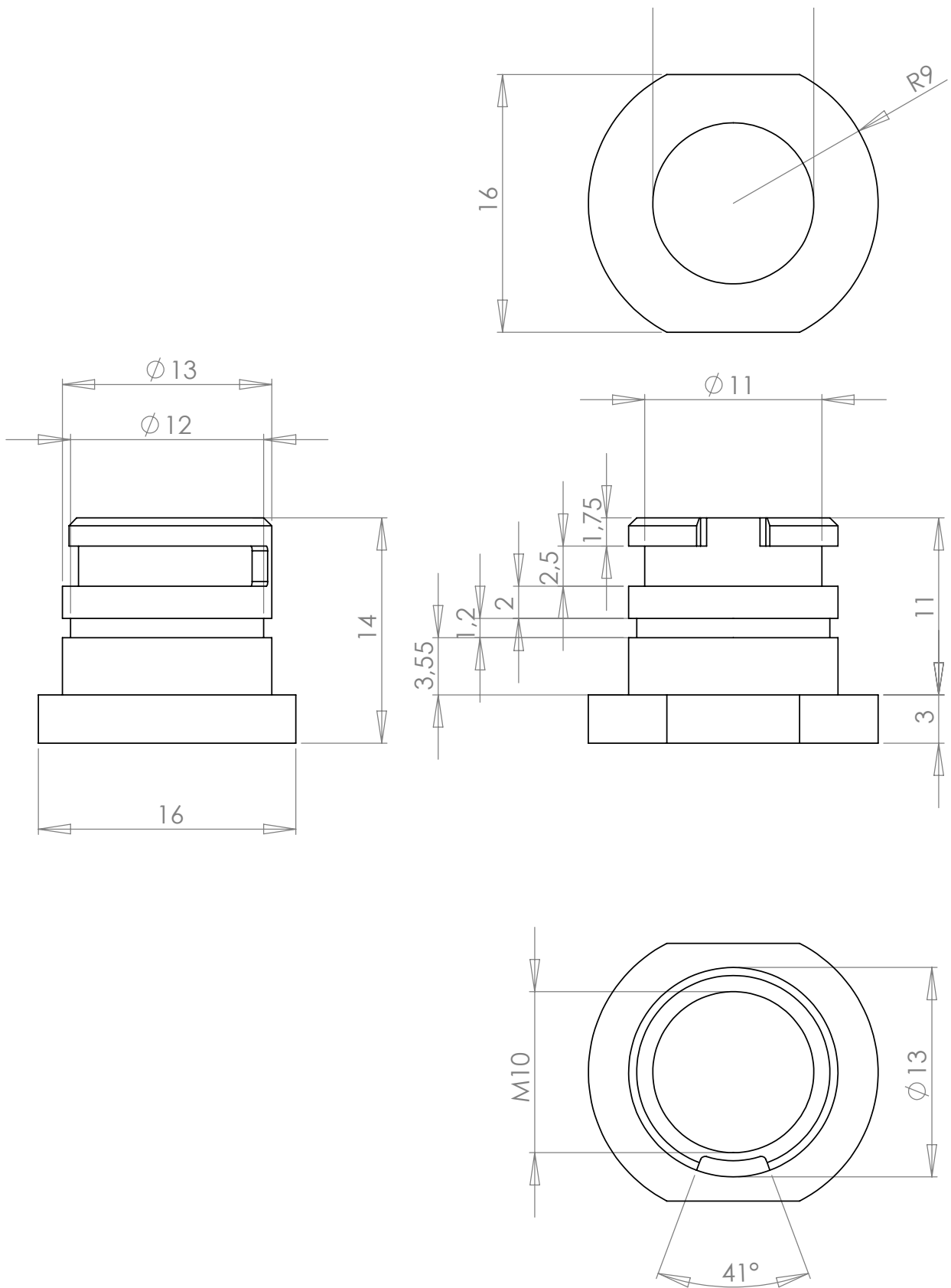

dcw.

Name : **BS RANGE**

Materials : NICKEL PLATED BRASS

Part : **BALL JOINT PART 5**

Date :

Rev : **2**

Details :

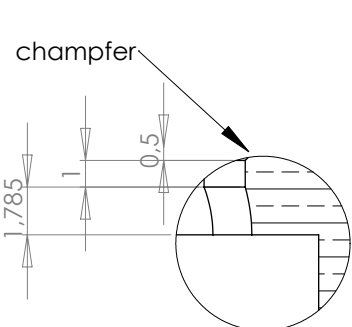

DÉTAIL B
ECHELLE 5 : 1

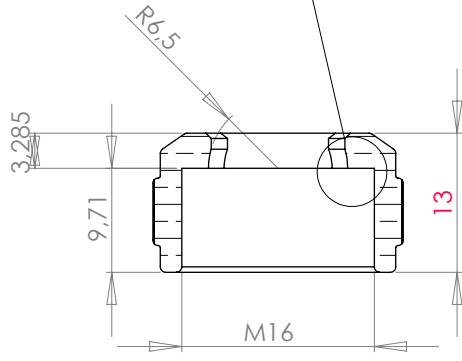

COUPE A-A

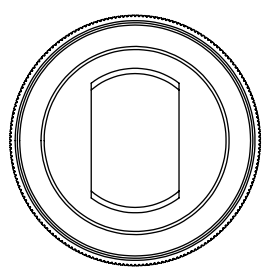
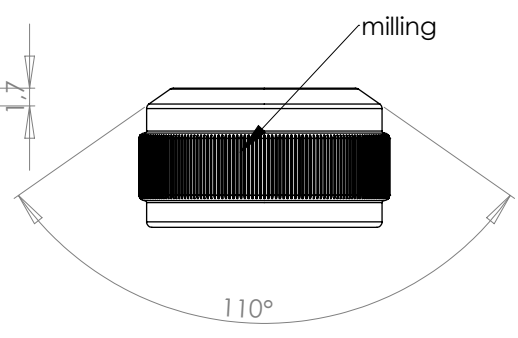
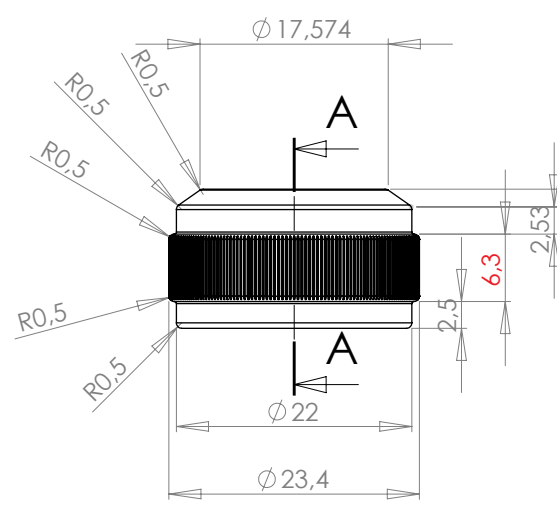
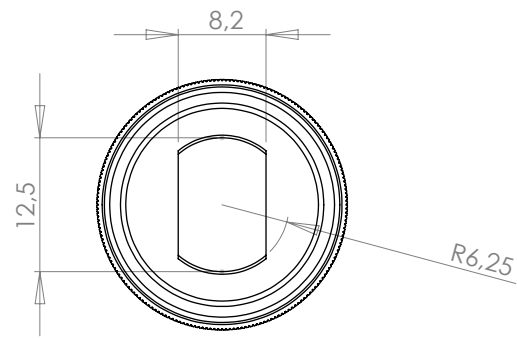

dcw.

Name : **BS RANGE**

Materials : NICKEL PLATED BRASS

Part : **BALL JOINT PART 4**

Date :

Rev : **4**

Details :

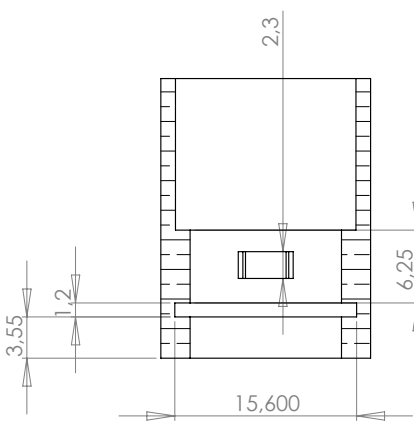
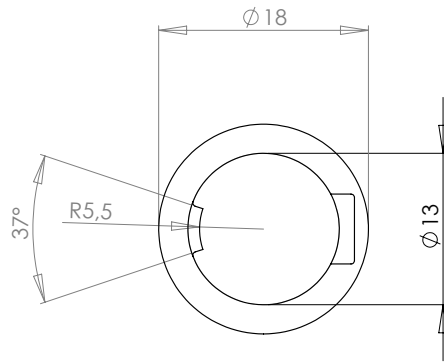

COUPE B-B

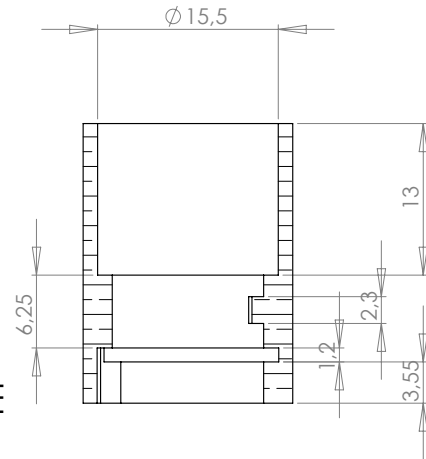
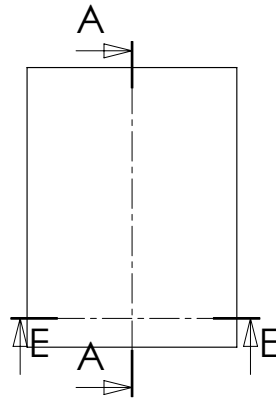
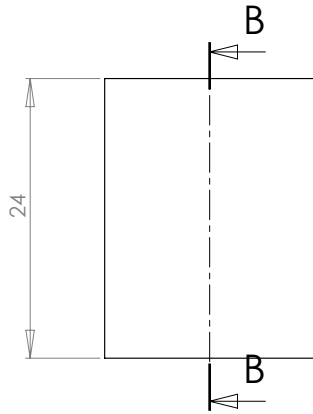

COUPE A-A

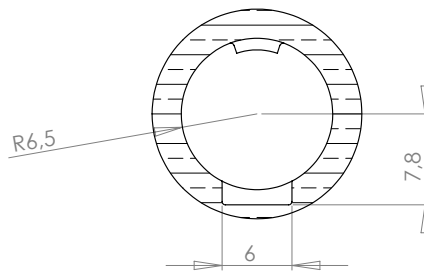

COUPE E-E

dcw.

Name : **BS RANGE**

Matériaux : NICKEL PLATED BRASS

Part : **BALL JOINT PART 3**

Date :

Rev : **3**

Details :

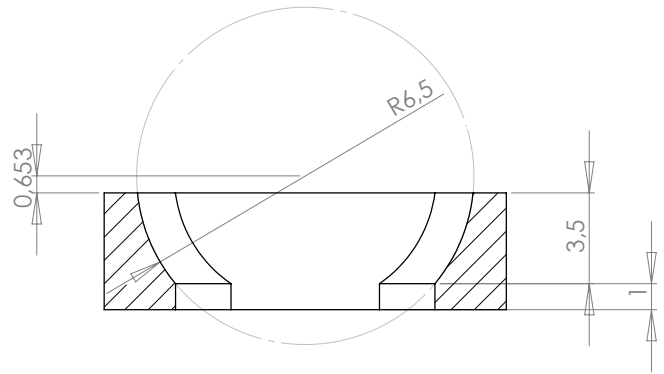
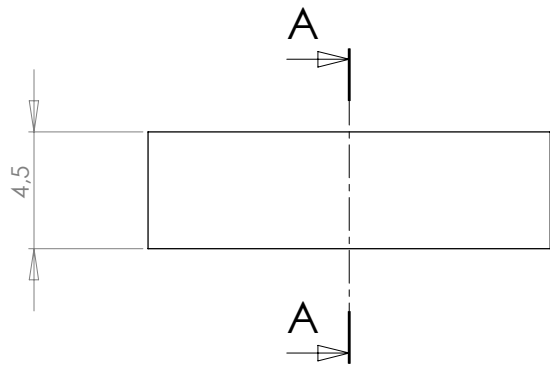
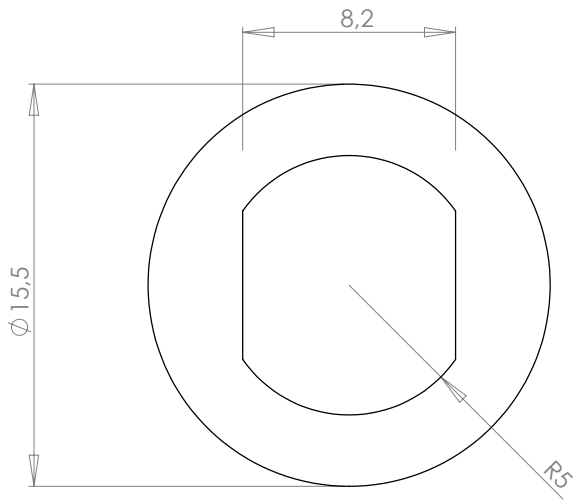

COUPE A-A

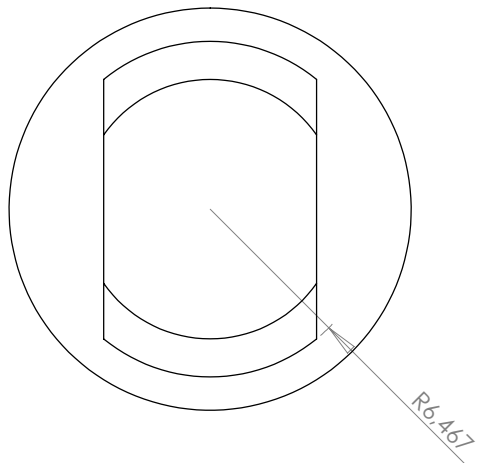

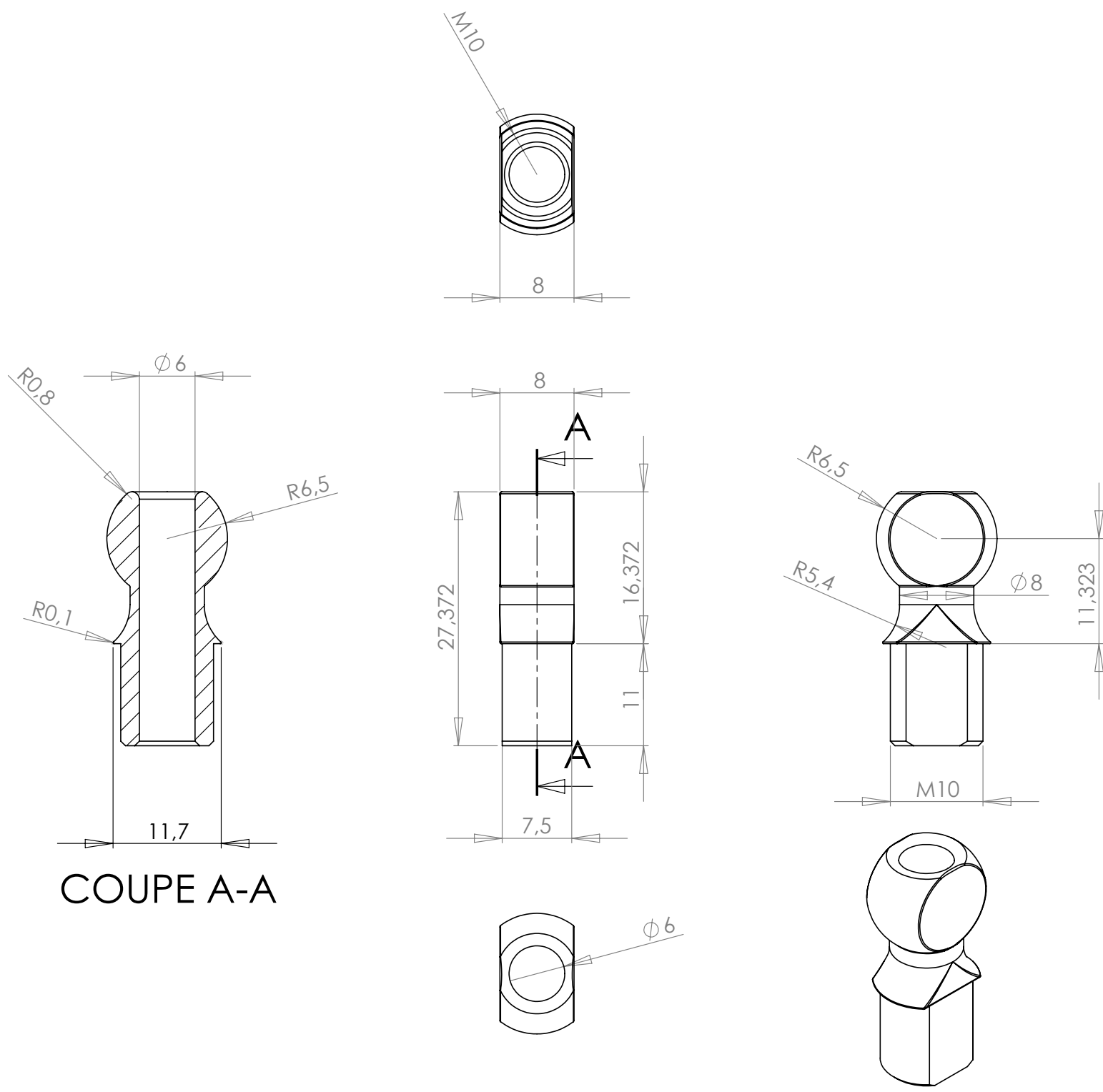

COUPE A-A

dcw.

| | | |
|---------------------------------|----------------|---------------------------------|
| Name : BS RANGE | | Materials : NICKEL PLATED BRASS |
| Part : BALL JOINT PART 1 | | |
| Date : | Rev : 2 | Details : |

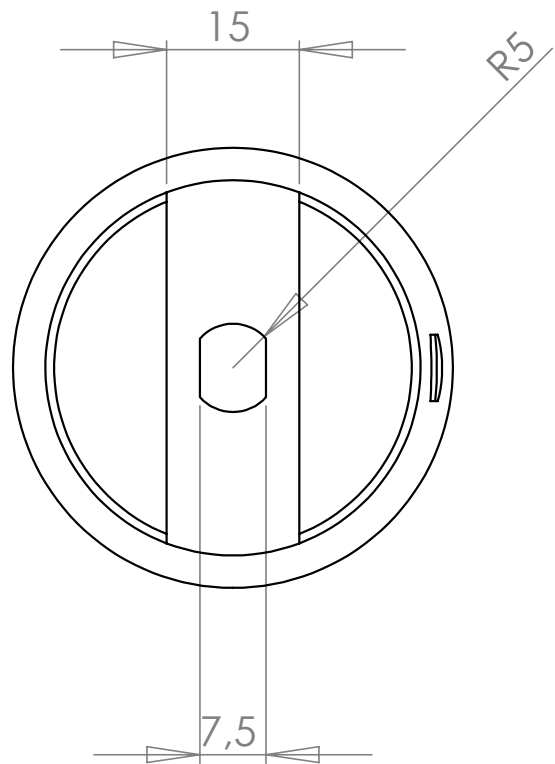
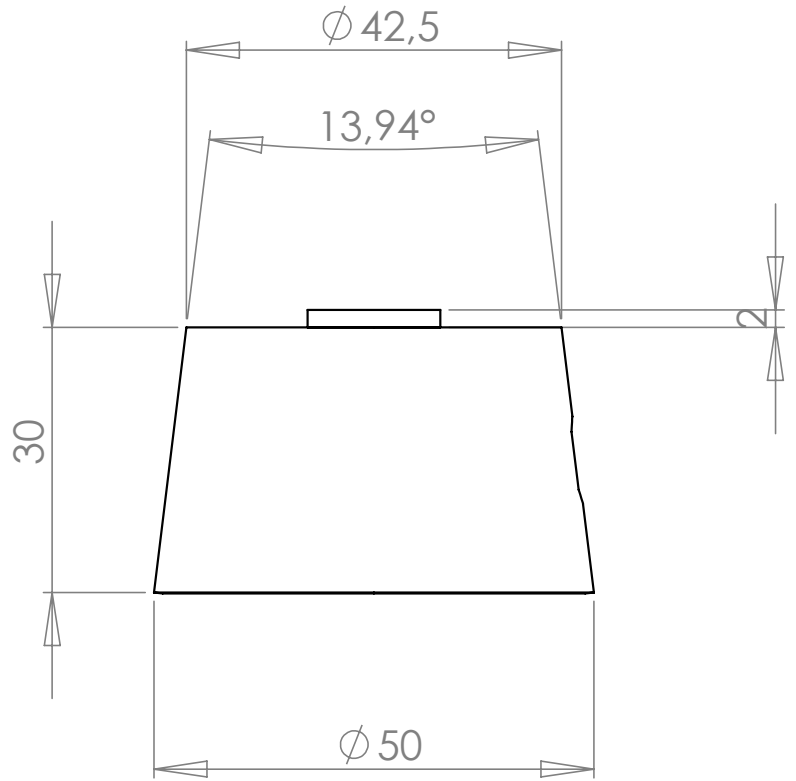
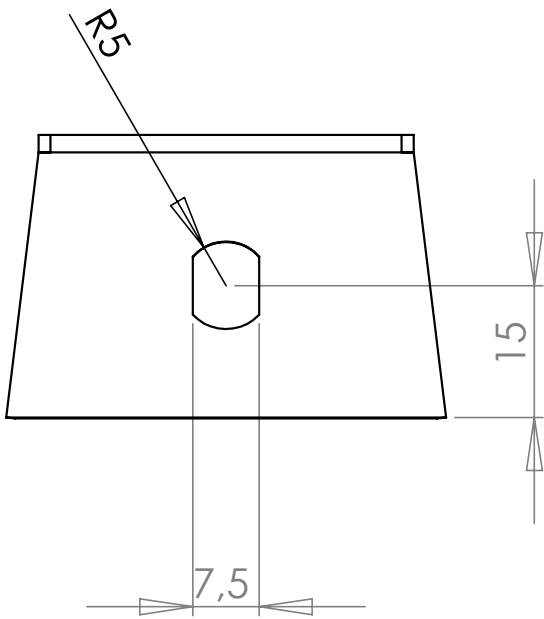

dcw.

Name : **BS3 TABLE**

Materials : PAINTED STEEL

Part : **JUNCTION PIECE**

Date :

Rev : 2

Details :

Name : **BS3 TABLE**
Part : **SHADE**
Date :

Rev : **3**

Materials : **PAINTED ALUMINIUM**
Details :

dcw.

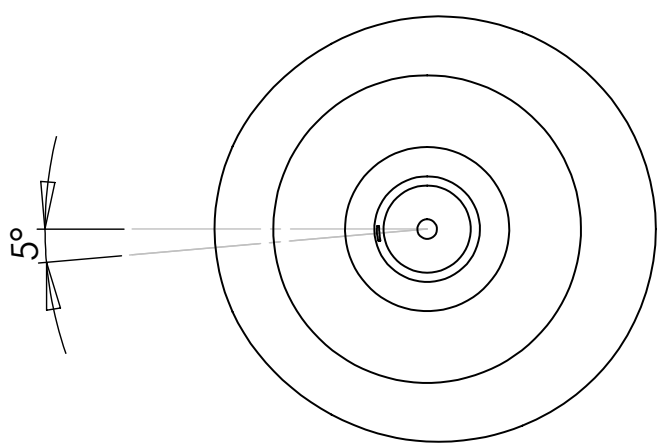
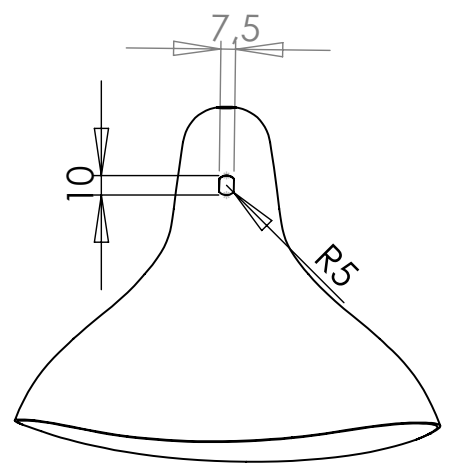
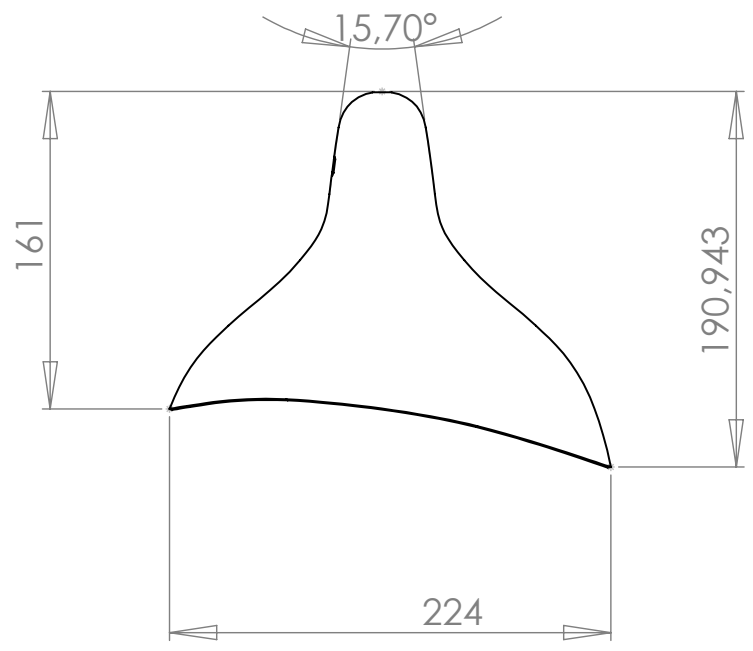
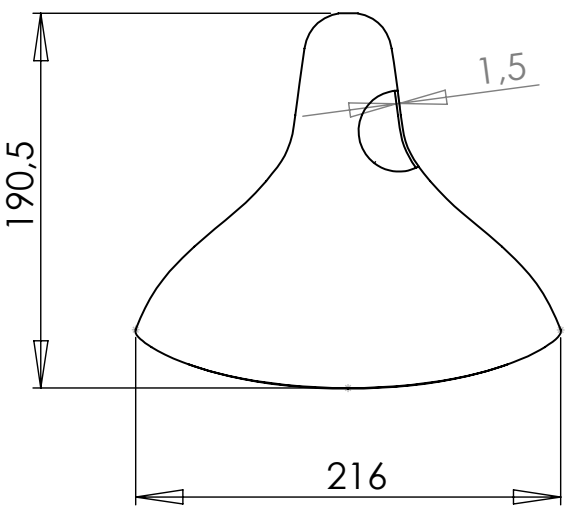

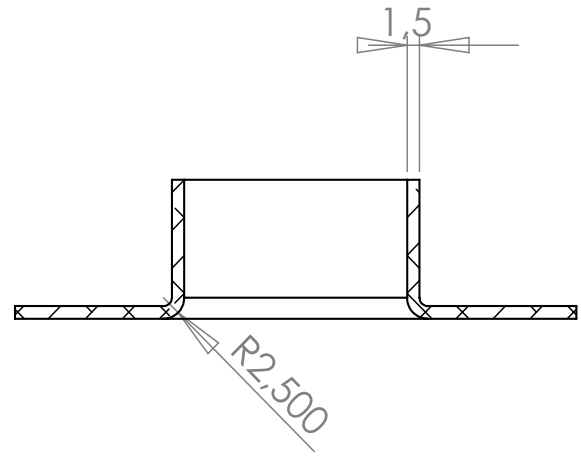
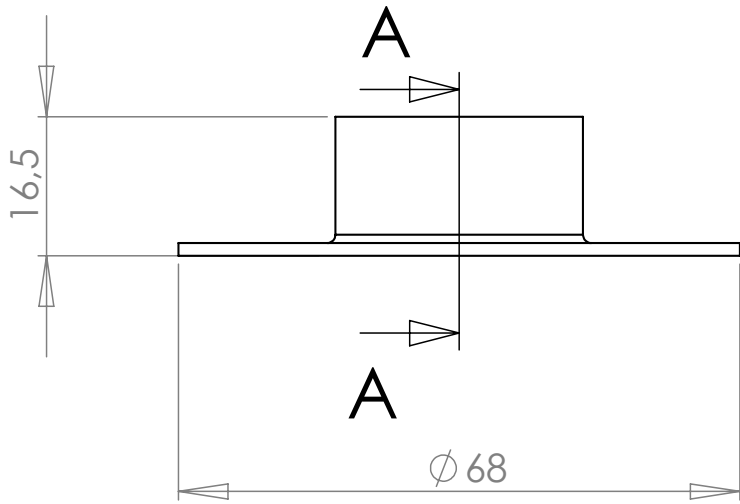

COUPE A-A

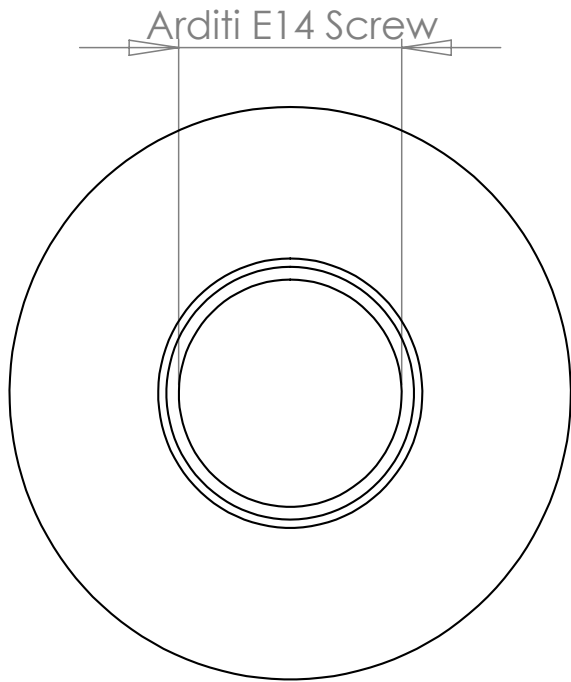

dcw.

Name : **BS1 FLOOR & BS2 WALL**

Matériaux : PAINTED STEEL

Part : **COVER CUP**

Date :

Rev : **2**

Details :