



Qty	Piece	Finishing
1	WALL CUP	MAT GREEN - PANTONE 5635U
1	BALL JOINT	MAT GREEN / NICKELED N8
1	CORD GRIPP	MAT GREEN - PANTONE 5635U
1	TUBE	MAT GREEN - PANTONE 5635U
1	SHADE	SATIN BLACK BK11 OUTSIDE / MAT WHITE INSIDE
1	JUNCTION PIECE	MAT WHITE
1	COVER CUP	MAT WHITE
1	THREAD 10x100	
1	BULBHOLDER	
2	M10 x 4 NUT	
2	M4 PLASTIC SCREW	

dcw.

Name : **BS4 L GR-BL**

Matériaux :

Part : **Finishings**

Date :

Rev : 1

Details : E14 - ESL 11W

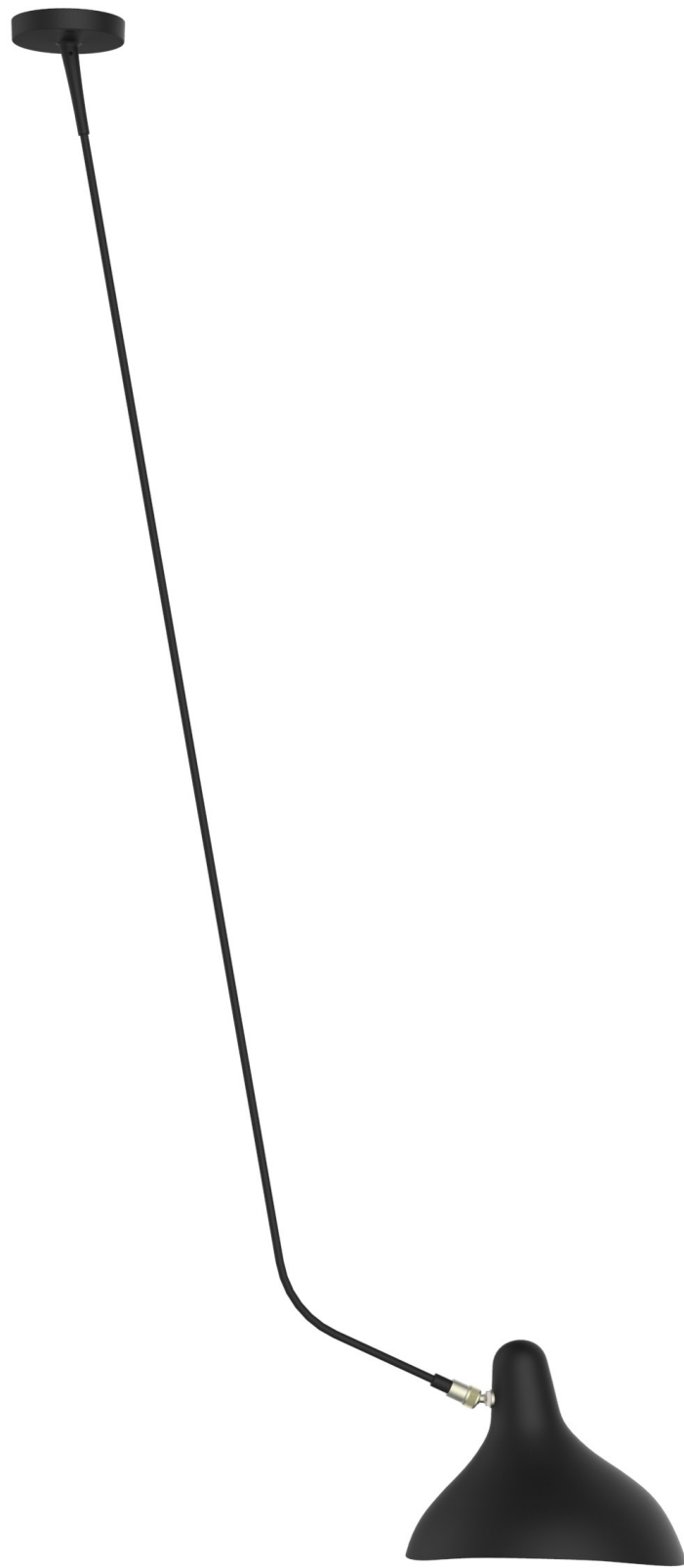

Qty	Piece	Finishing
1	WALL CUP	MAT BLACK
2	BALL JOINT	MAT BLACK / NICKELED N8
1	CORD GRIPP	MAT BLACK
1	TUBE	MAT BLACK
1	SHADE	MAT BLACK OUTSIDE / MAT WHITE INSIDE
1	JUNCTION PIECE	MAT WHITE
1	COVER CUP	MAT WHITE
1	THREAD 10x100	
1	BULBHOLDER	
2	M10 x 4 NUT	
2	M4 PLASTIC SCREW	

dcw.

Name : **BS4 L BL**

Matériaux :

Part : **Finishings**

Date :

Rev : 1

Details : E14 - ESL 11W

Name : **BS4 L**
Part : **Wall Cup**
Date :

Rev : 2

Materials : Painted steel
Details : E14 - ESL 11W

dcw.

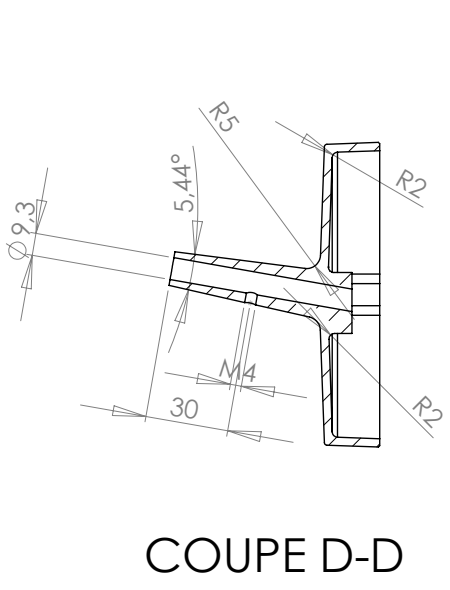

COUPE D-D

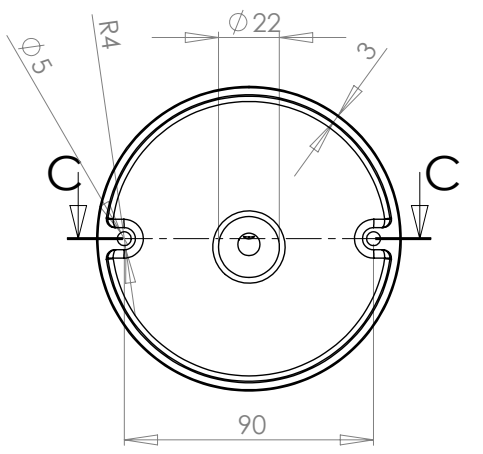
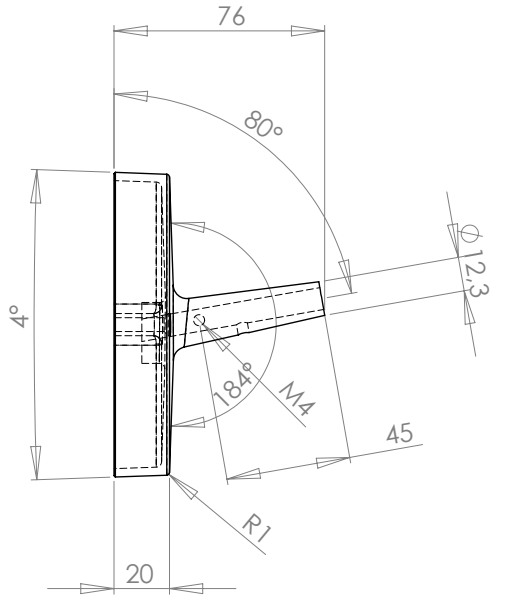
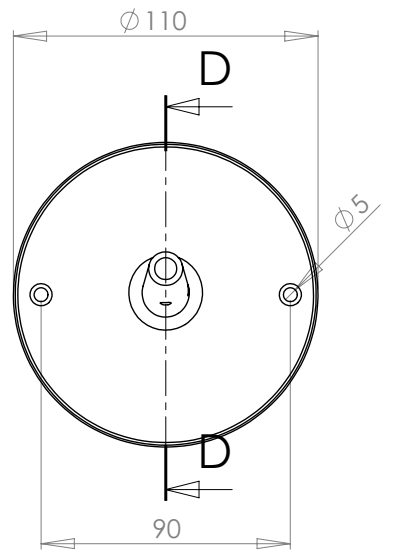

COUPE C-C

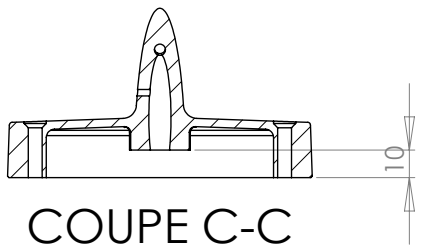

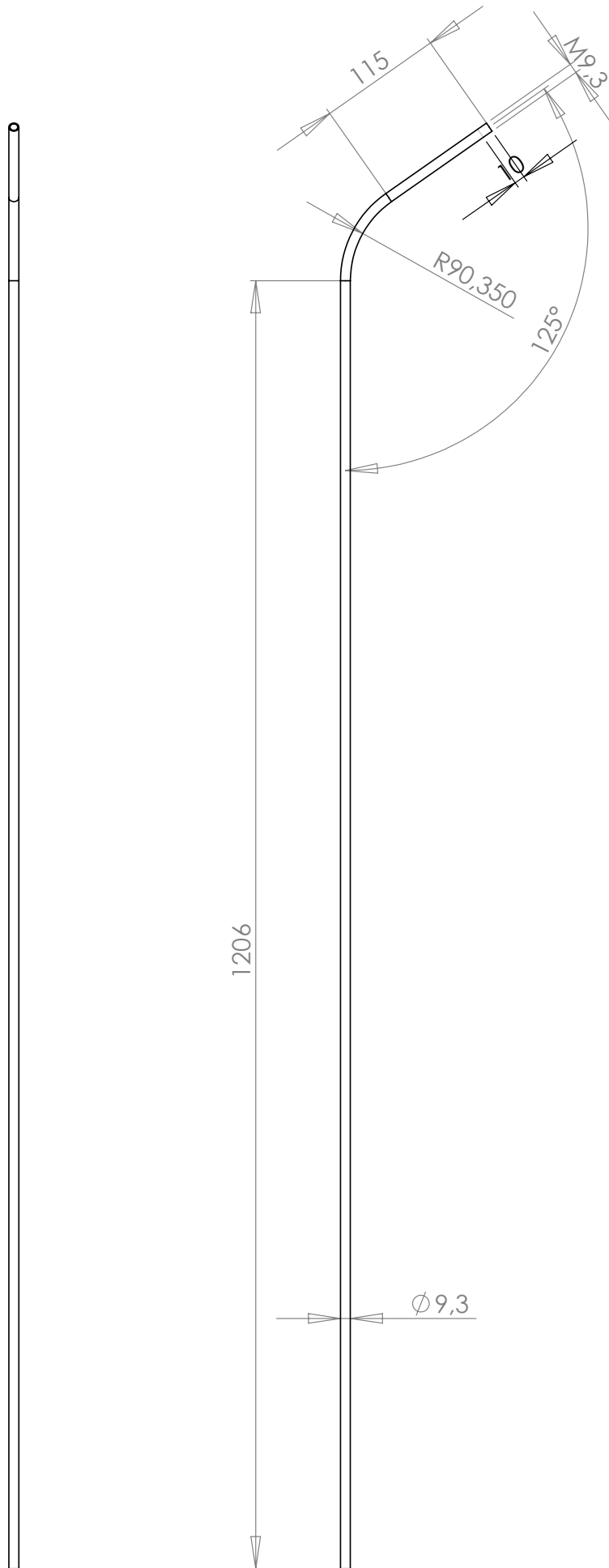

dcw.

Name : **BS4 L**

Materials : Painted steel

Part : **Tube**

Date :

Rev : 2

Details : E14 - ESL 11W

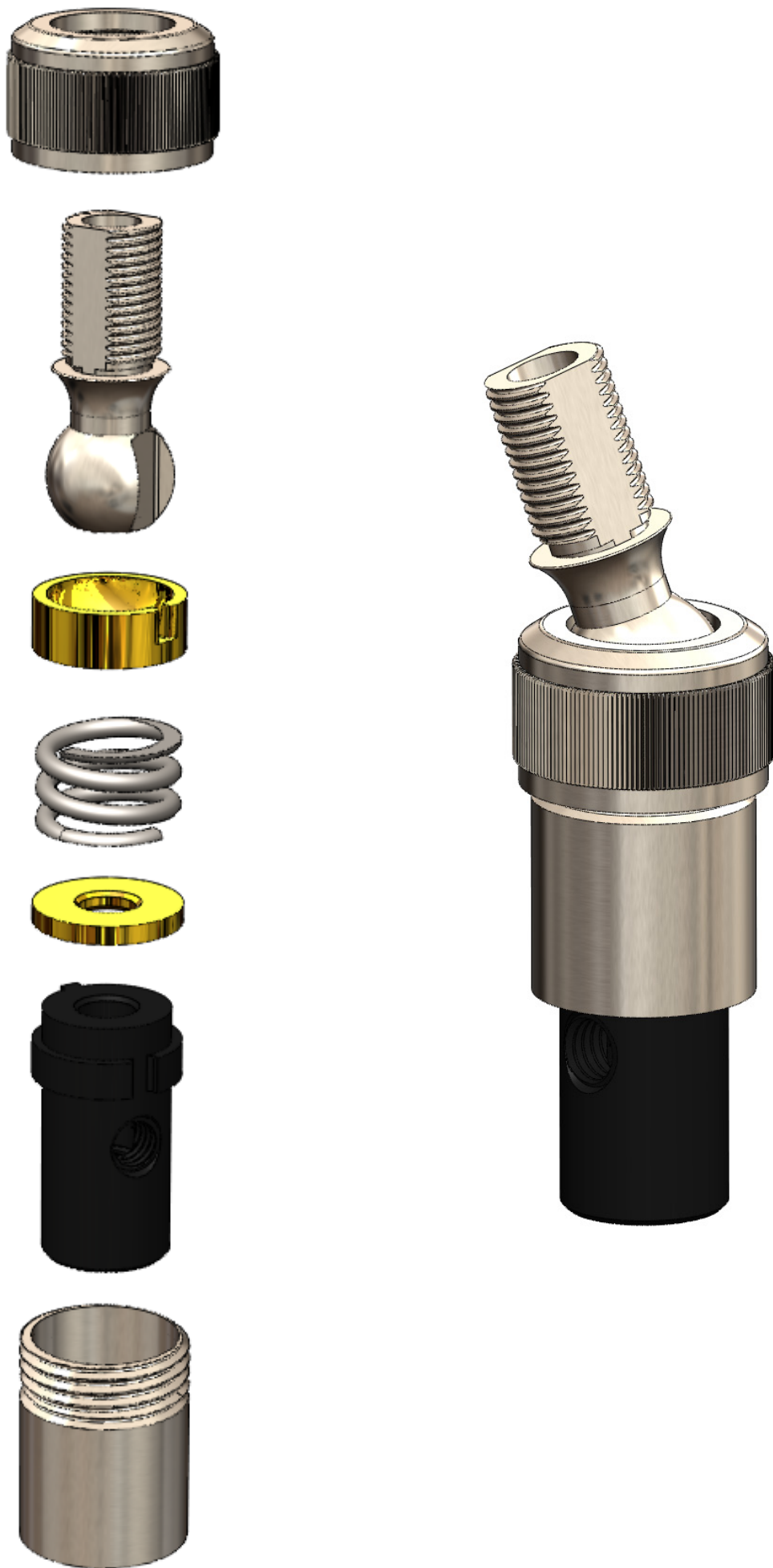

dcw.

Name : **BS RANGE**

Materials : NICKEL PLATED BRASS

Part : **BALL JOINT**

Date :

Rev : 1

Details :

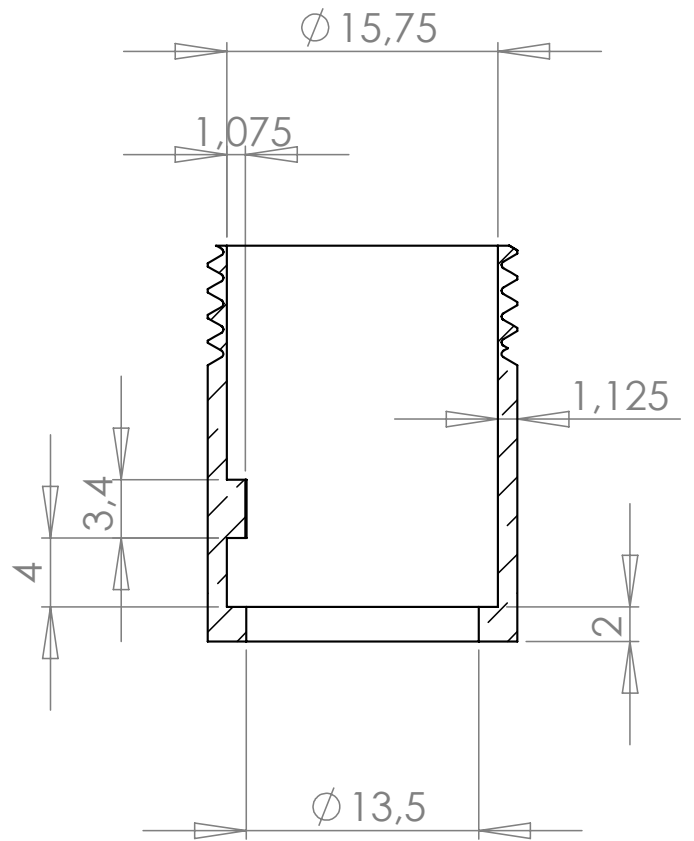
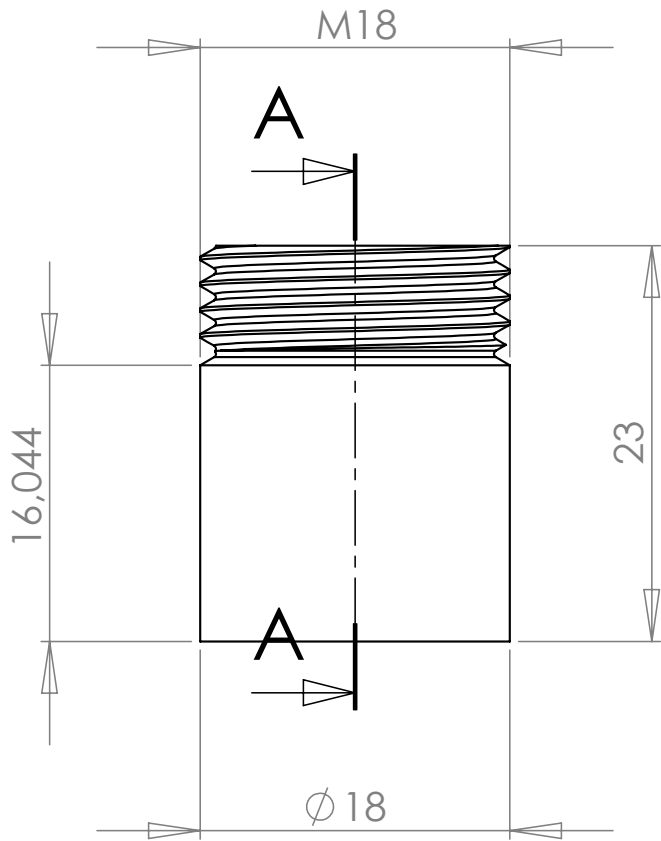

COUPE A-A

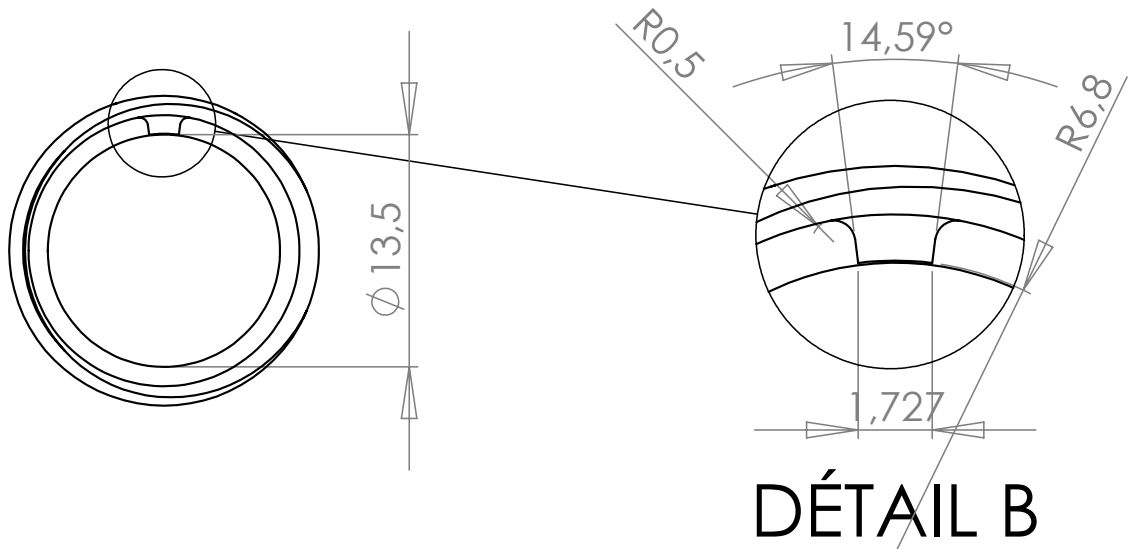

DÉTAIL B

dcw.

Name : **BS RANGE**

Materials : NICKEL PLATED BRASS

Part : **BALL JOINT – PART 1**

Date :

Rev : 1

Details :

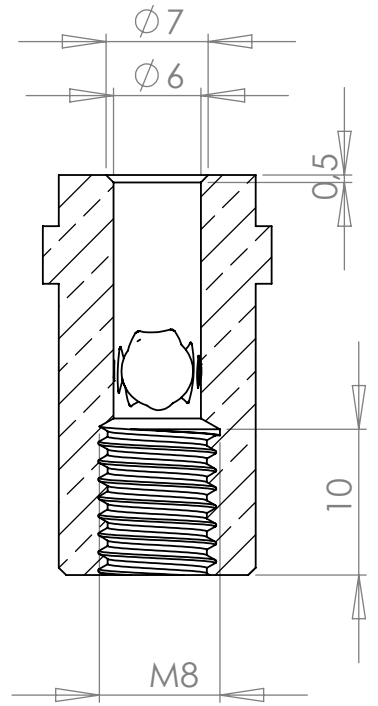
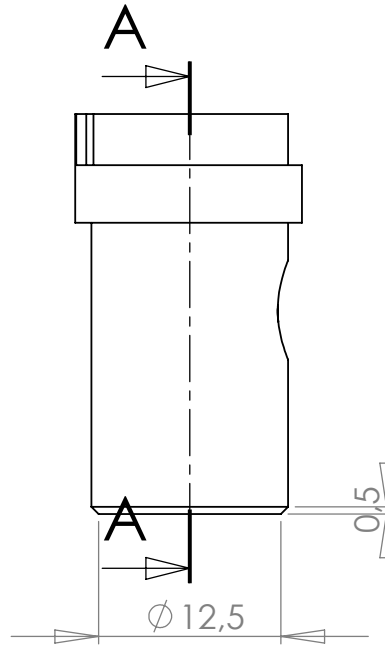
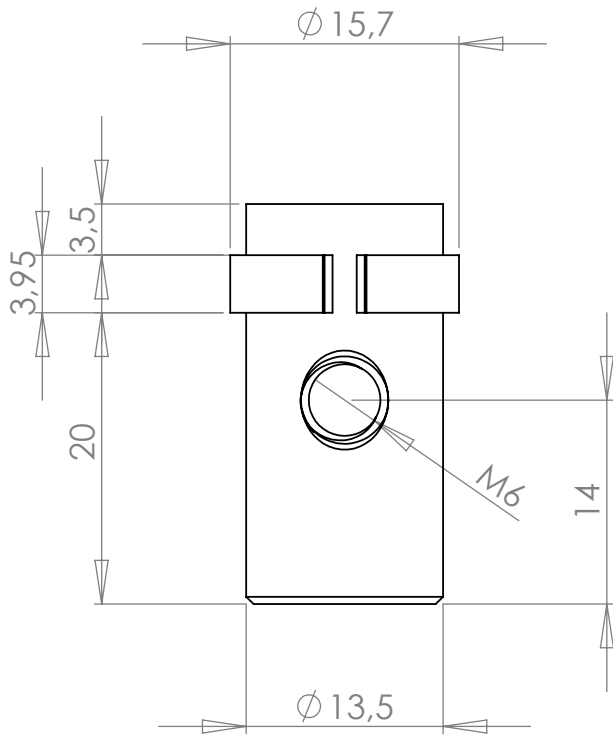

COUPE A-A

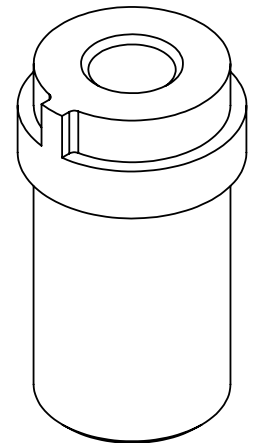
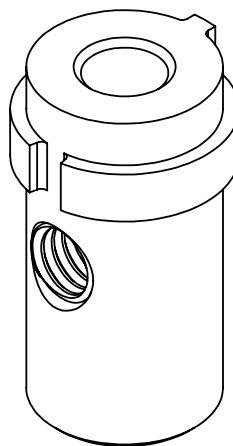
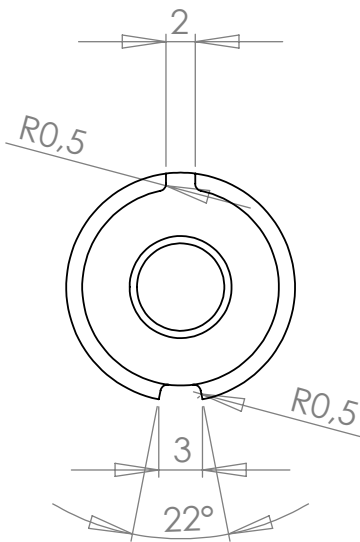

dcw.

Name : **BS RANGE**

Materials : NICKEL PLATED BRASS

Part : **BALL JOINT – PART 2**

Date :

Rev : 1

Details :

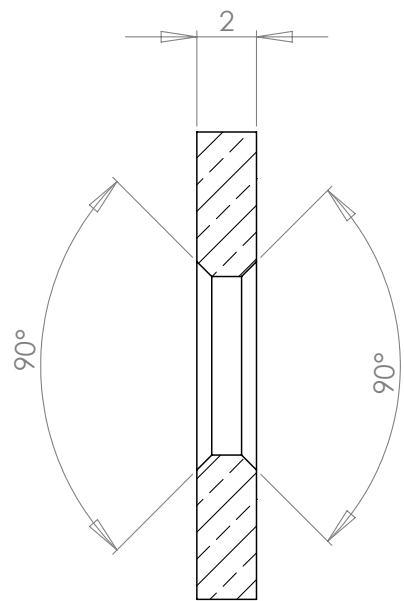
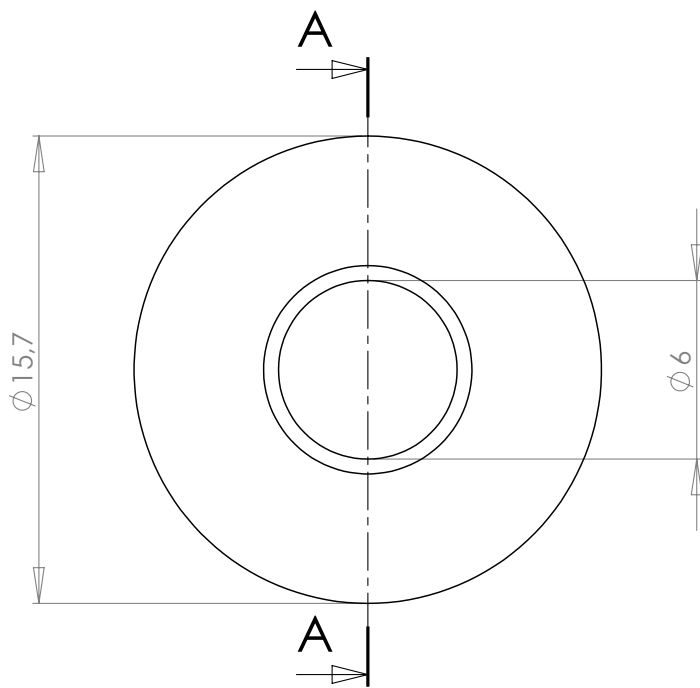

COUPE A-A

dcw.

Name : **BS RANGE**

Matériaux : NICKEL PLATED BRASS

Part : **BALL JOINT – WASHER**

Date :

Rev : **1**

Details :

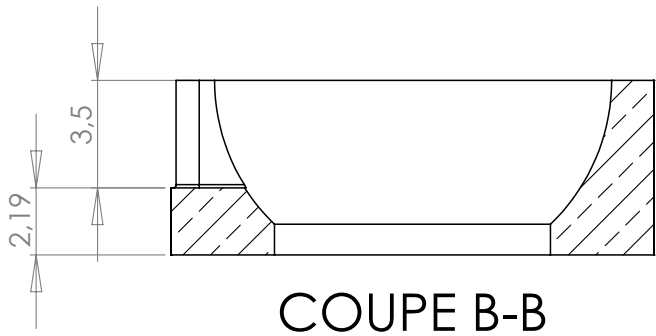

COUPE B-B

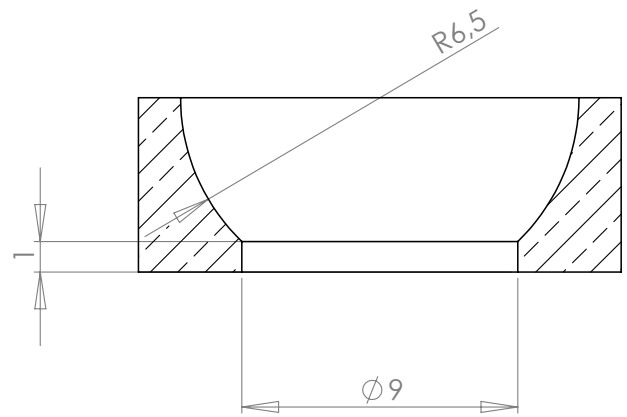
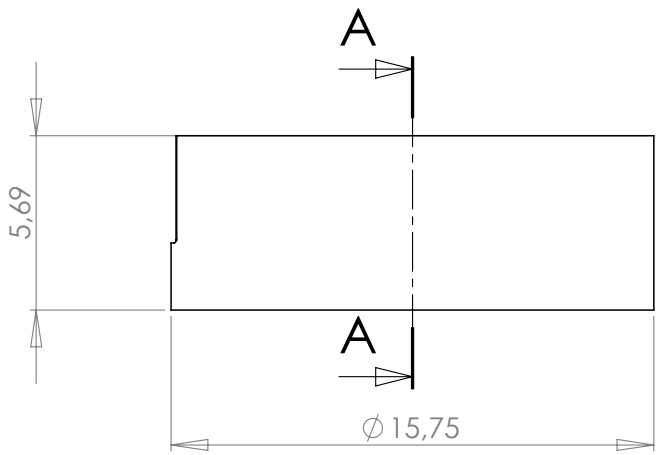

COUPE A-A

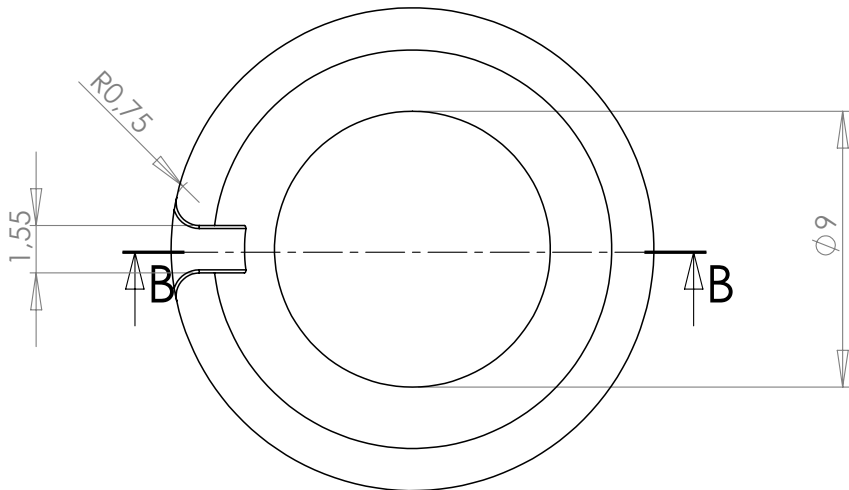

dcw.

Name : **BS RANGE**

Matériaux : NICKEL PLATED BRASS

Part : **BALL JOINT – PART 3.2**

Date :

Rev : 1

Details :

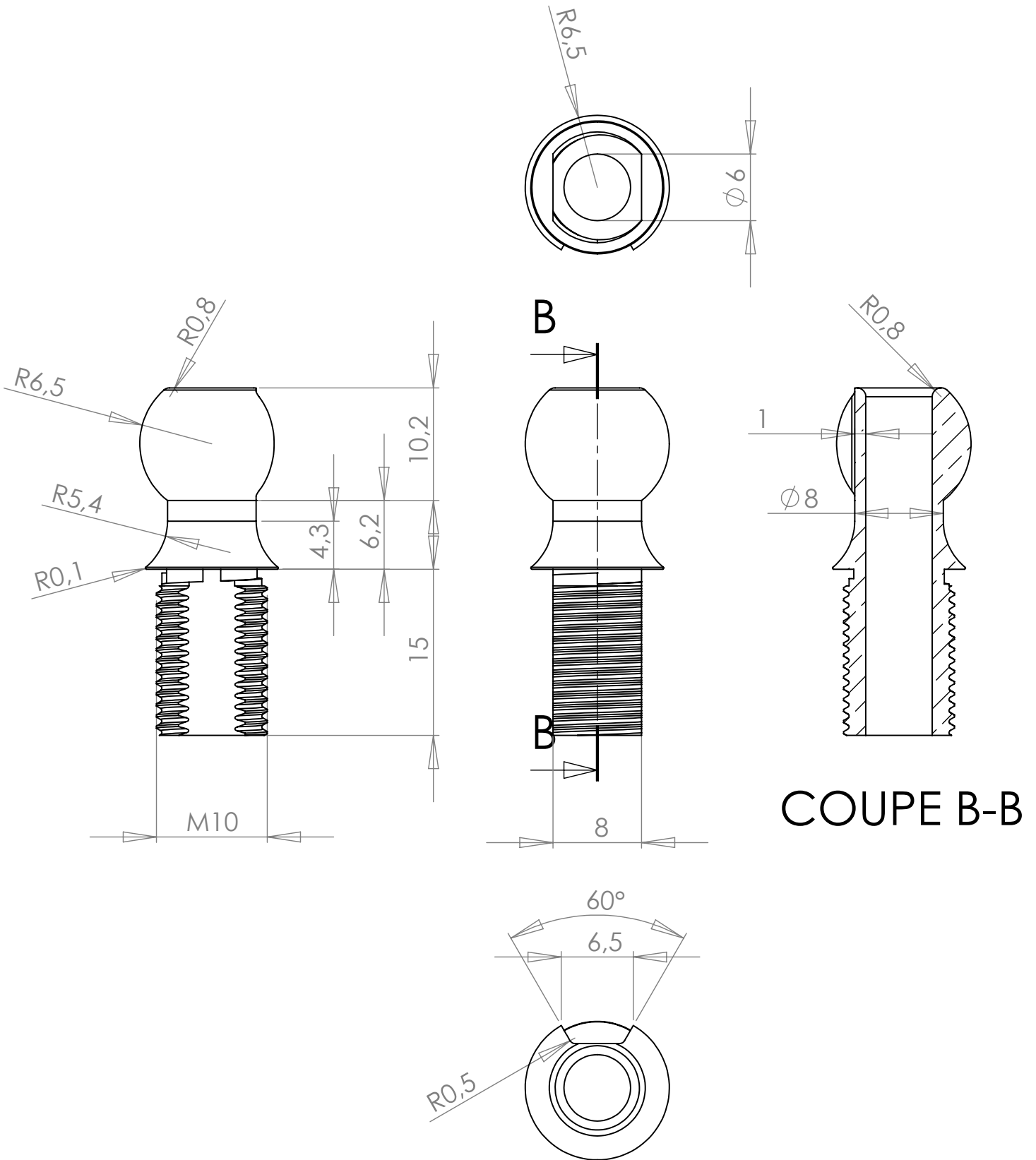

COUPE B-B

dcw.

Name : **BS RANGE**

Materials : NICKEL PLATED BRASS

Part : **BALL JOINT – PART 5.2**

Date :

Rev : 1

Details :

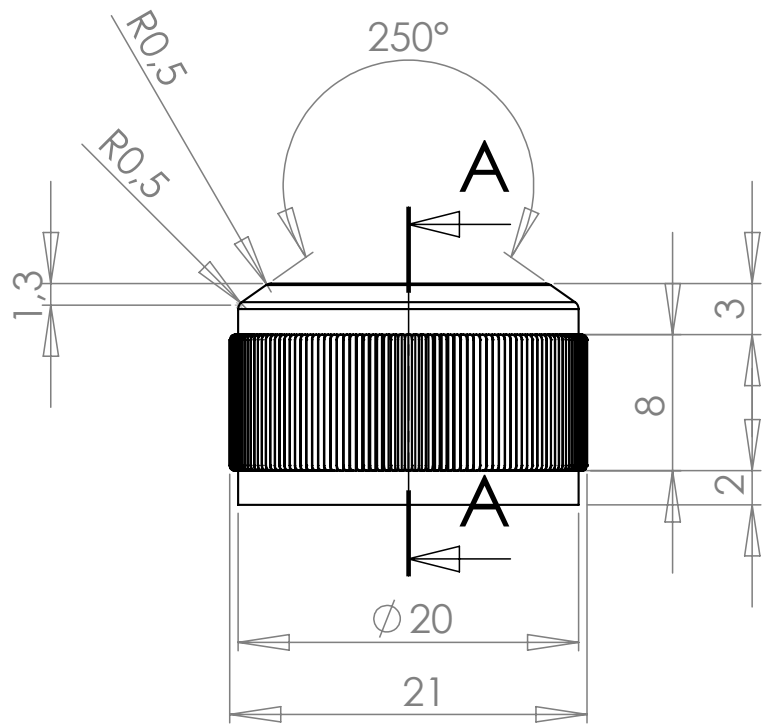
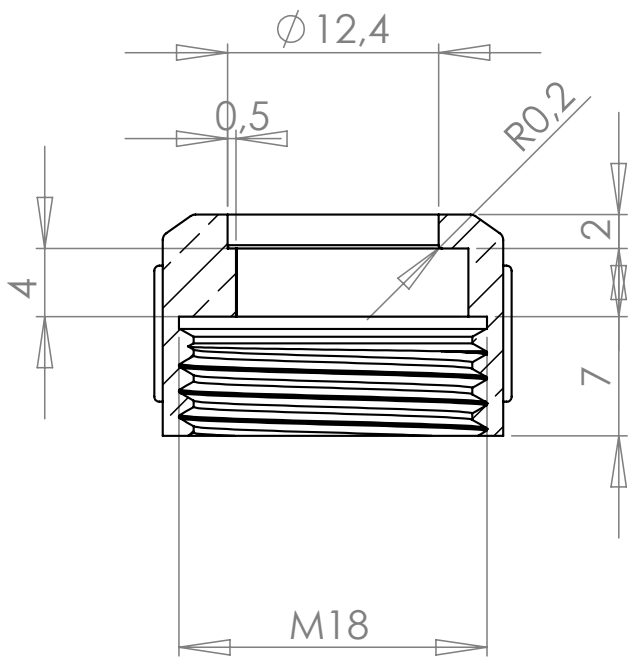
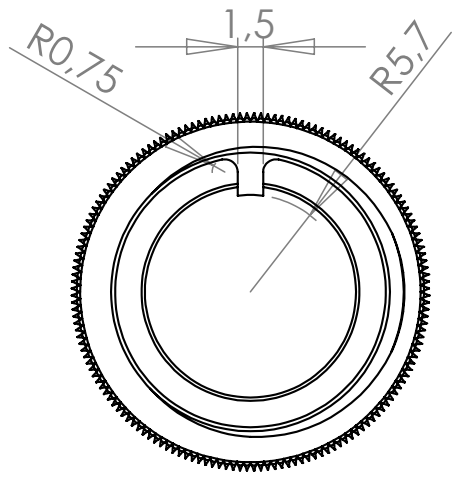

COUPE A-A

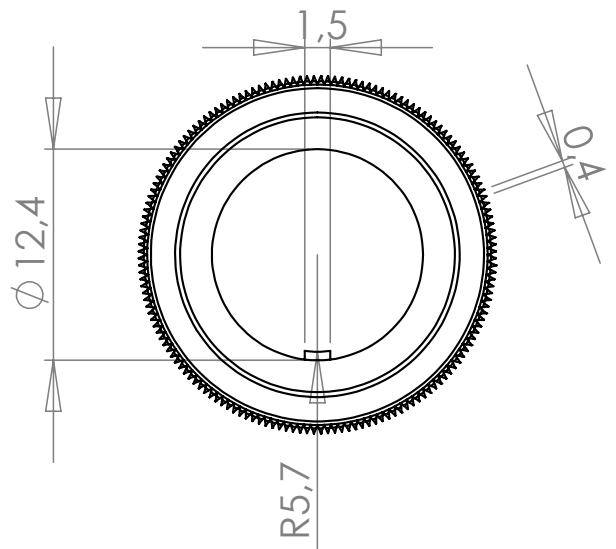

dcw.

Name : **BS RANGE**

Materials : NICKEL PLATED BRASS

Part : **BALL JOINT – PART 4.2**

Date :

Rev : 1

Details :

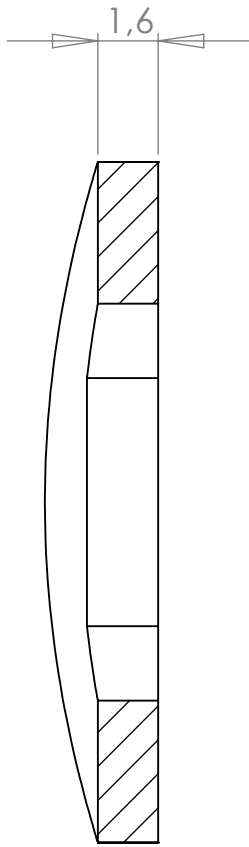
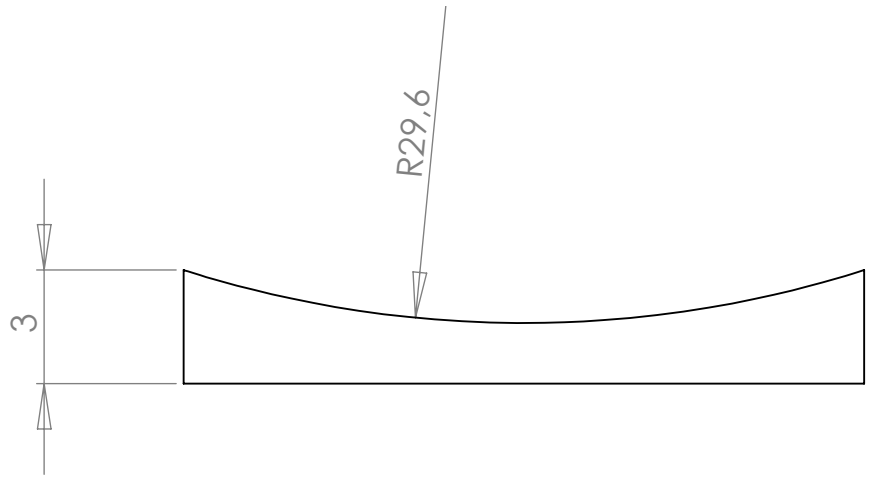

COUPE A-A

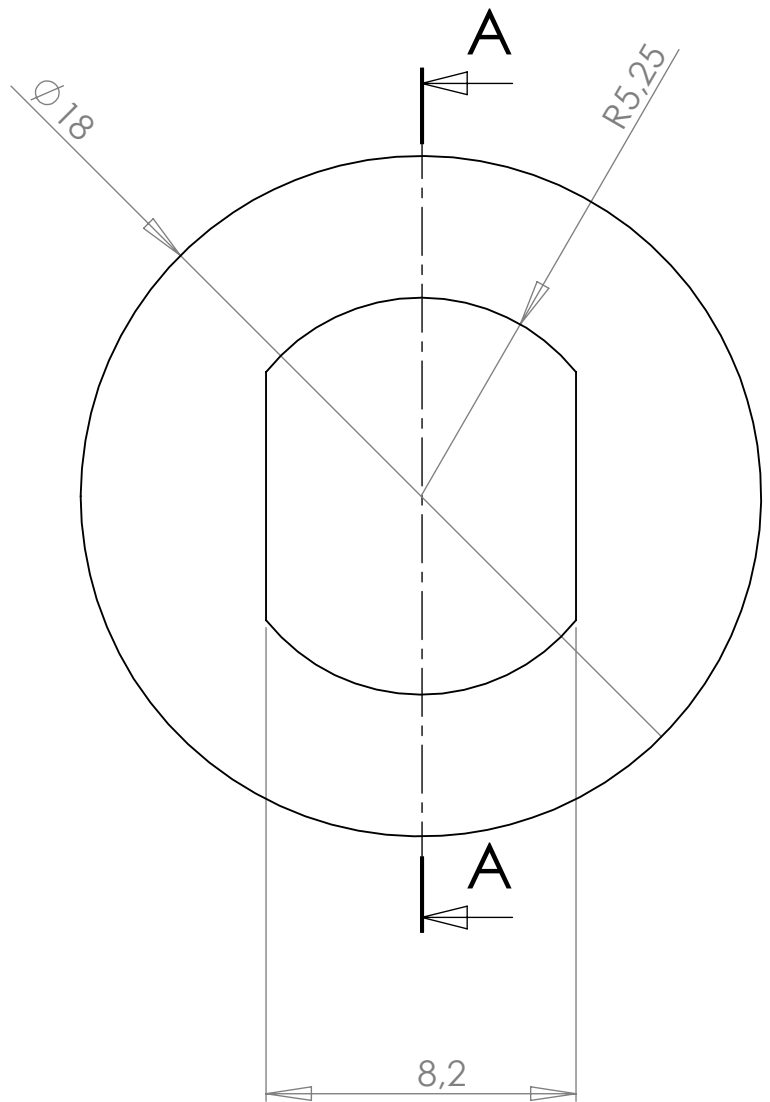

dcw.

Name : **BS RANGE**

Matériaux : PAINTED STEEL

Part : **CURVED WASHER**

Date :

Rev : 2

Details :

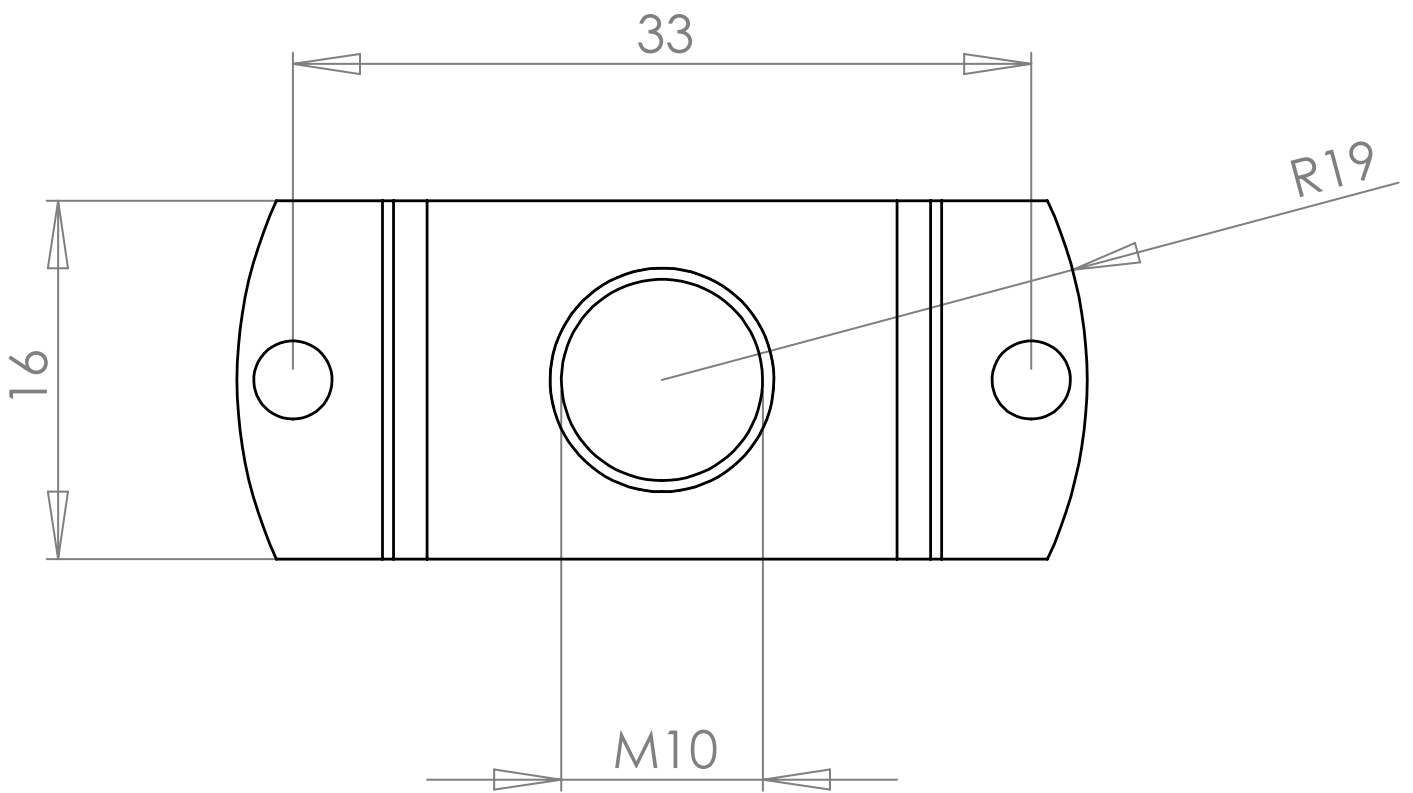
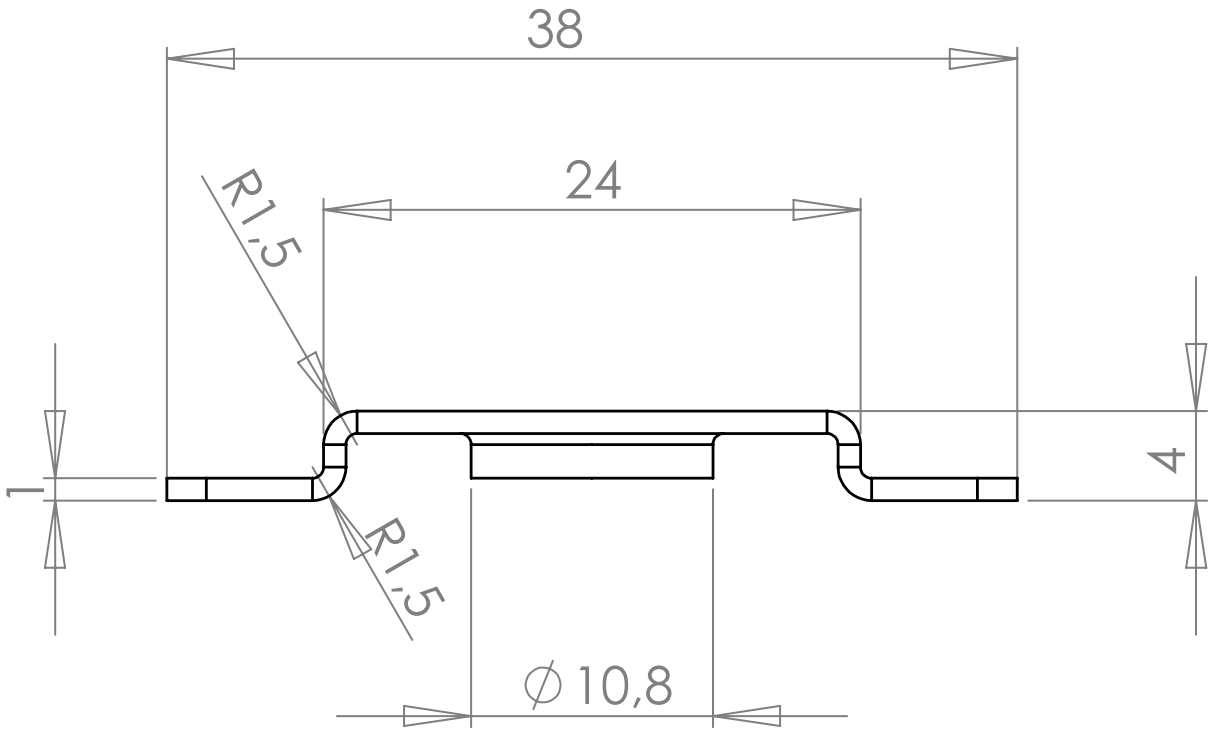

dcw.

Name : **BS RANGE**

Materials : PAINTED STEEL

Part : **JUNCTION PIECE 2**

Date :

Rev : 2

Details :

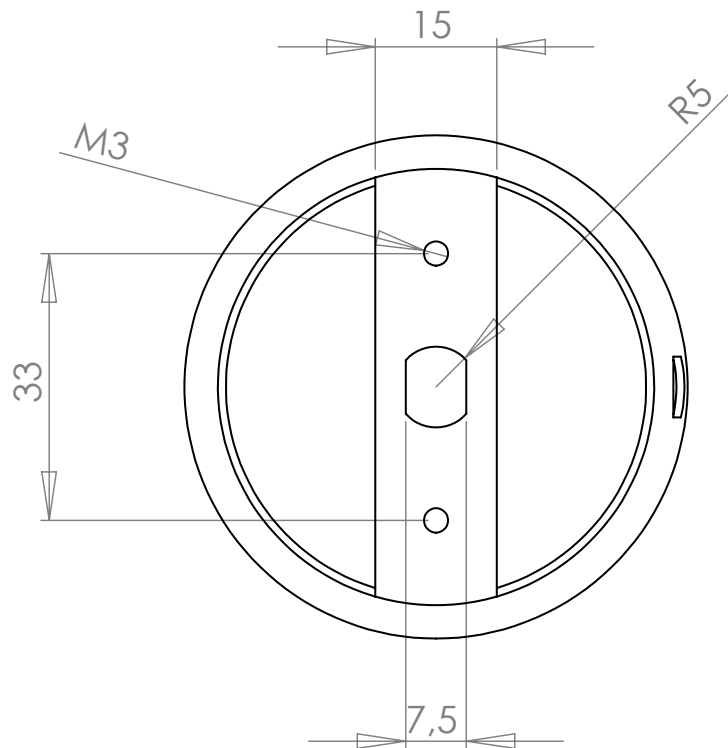
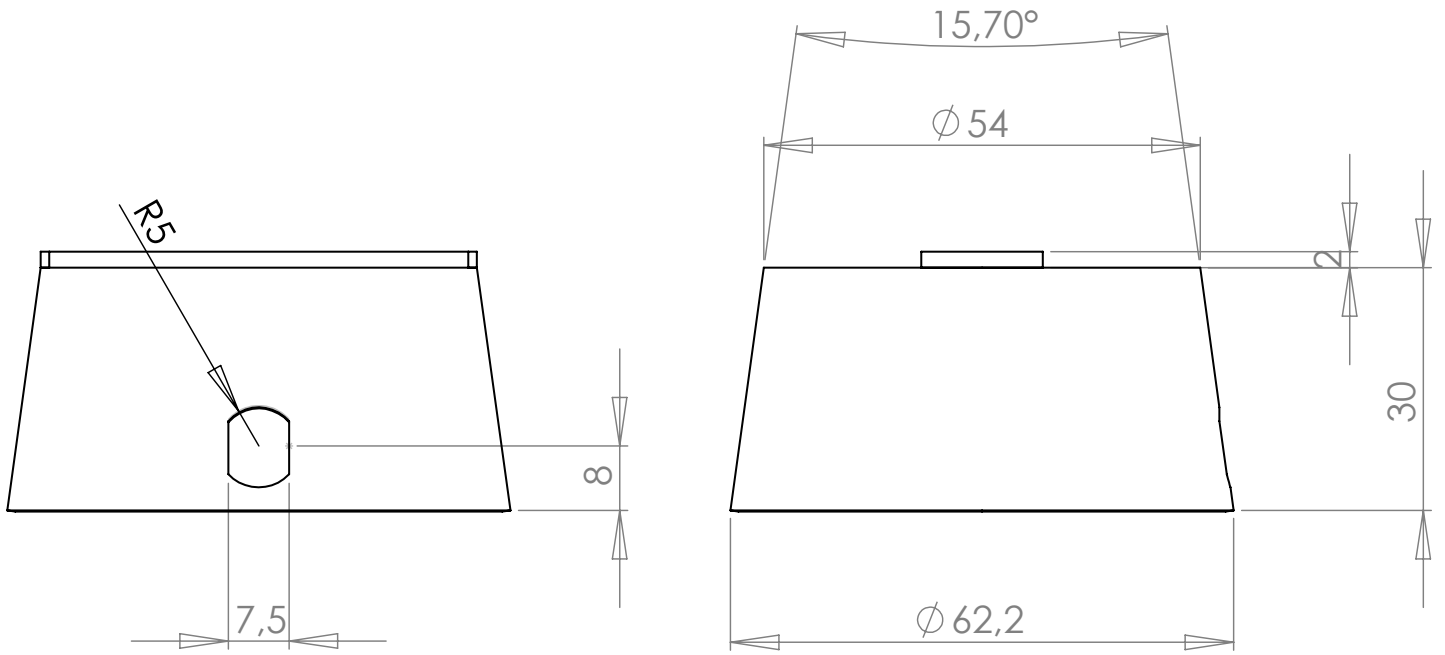

dcw.

Name : **BS1, BS2, BS4**

Materials : PAINTED STEEL

Part : **JUNCTION PIECE**

Date :

Rev : 2

Details :

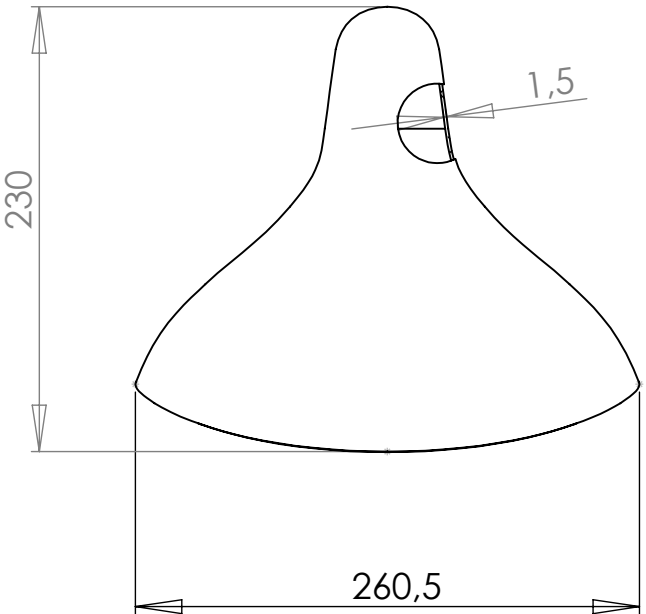
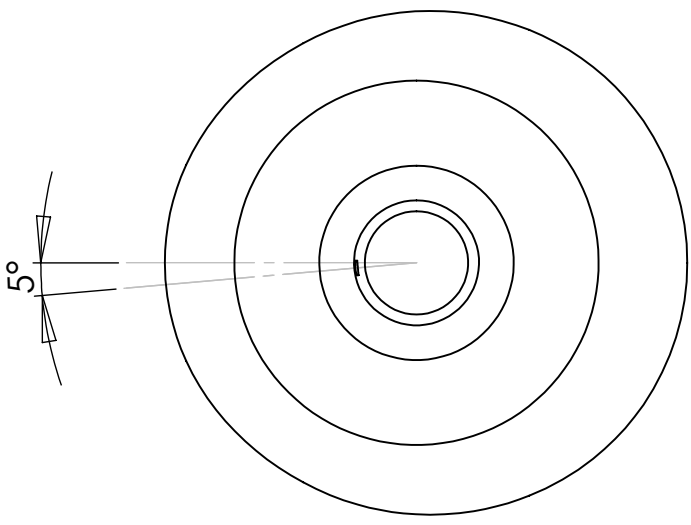
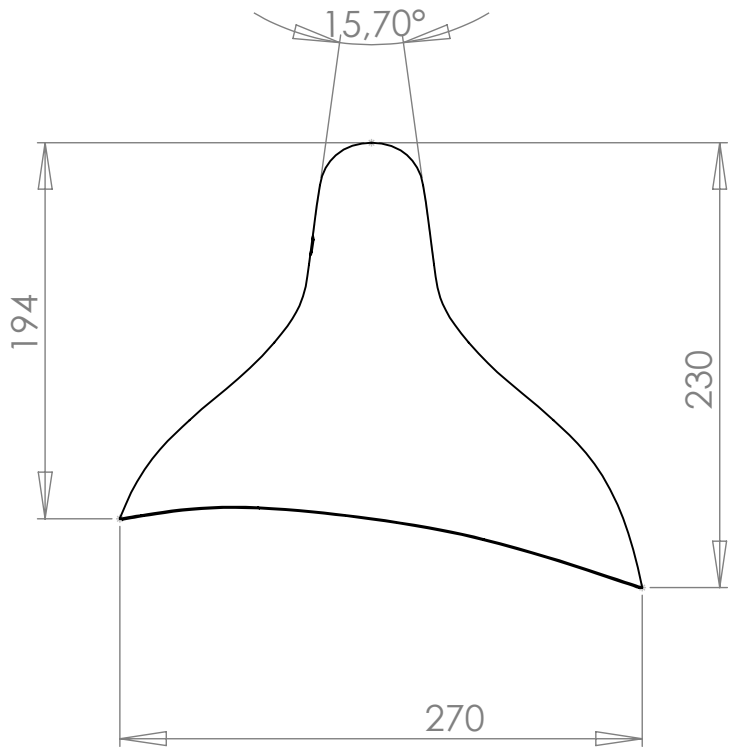
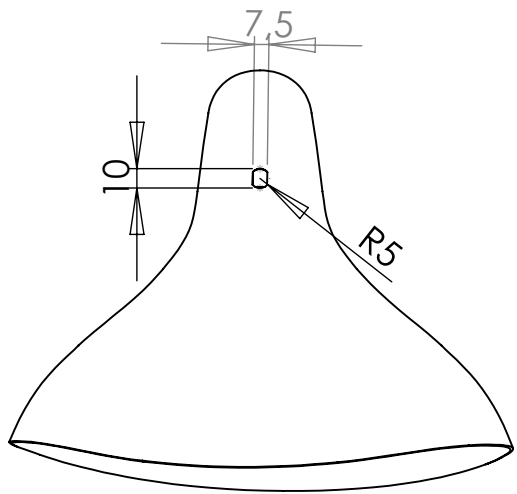

dcw.

Name : **BS RANGE**

Part : **LARGE SHADE**

Date :

Materials : PAINTED ALUMINIUM

Rev : 3

Details :

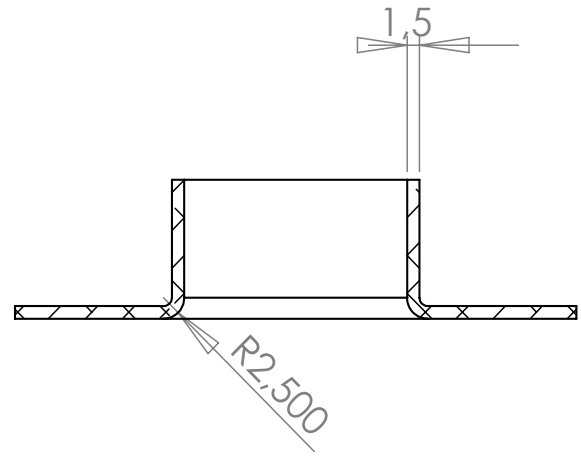
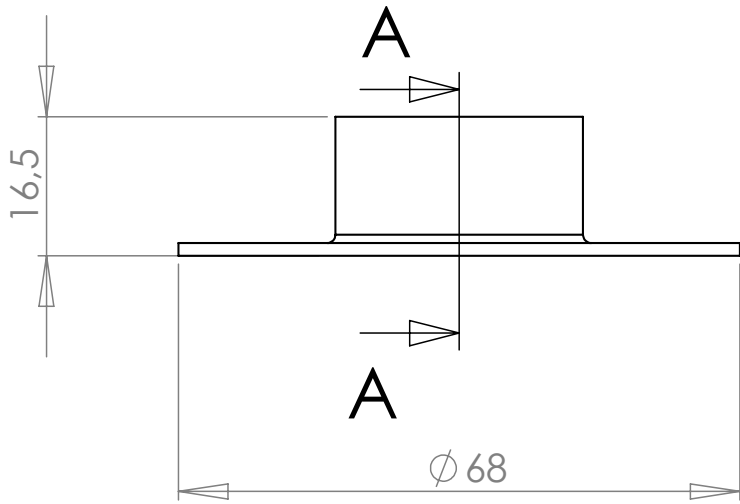

COUPE A-A

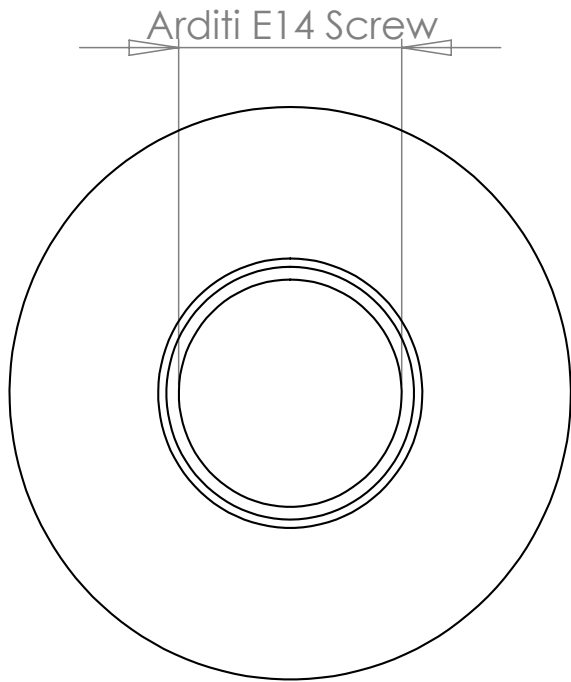

dcw.

Name : BS1 FLOOR & BS2 WALL

Matériaux : PAINTED STEEL

Part : COVER CUP

Date :

Rev : **2**

Details :