

COUPE A-A

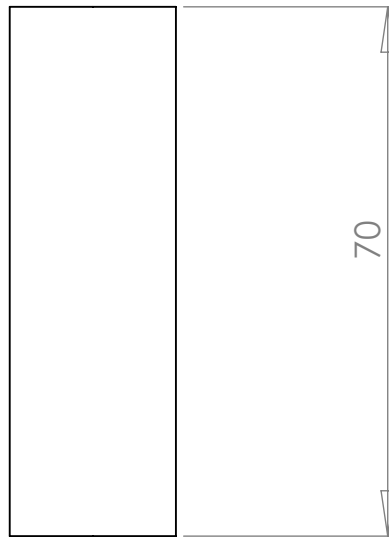

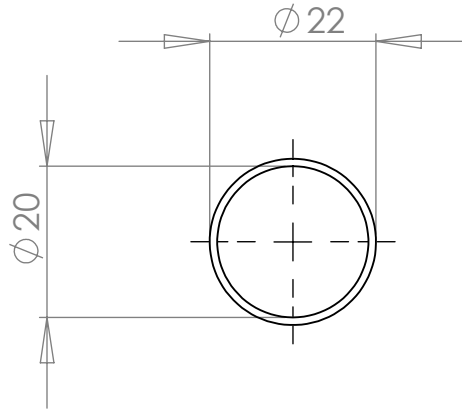

COUPE A-A

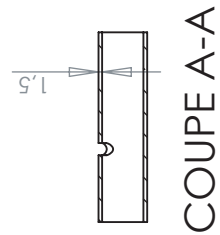
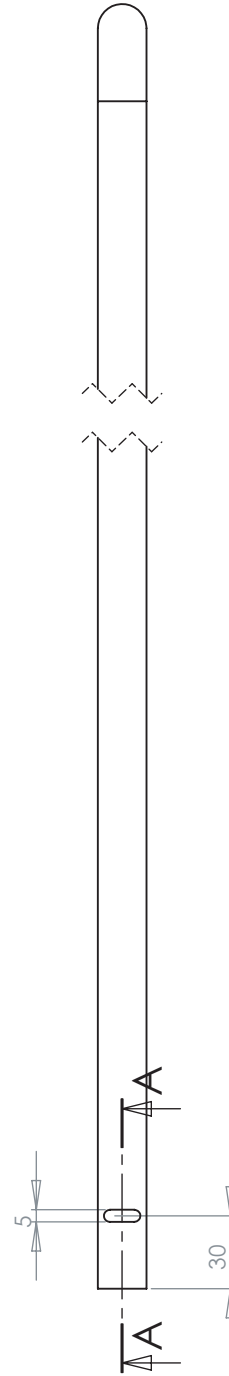
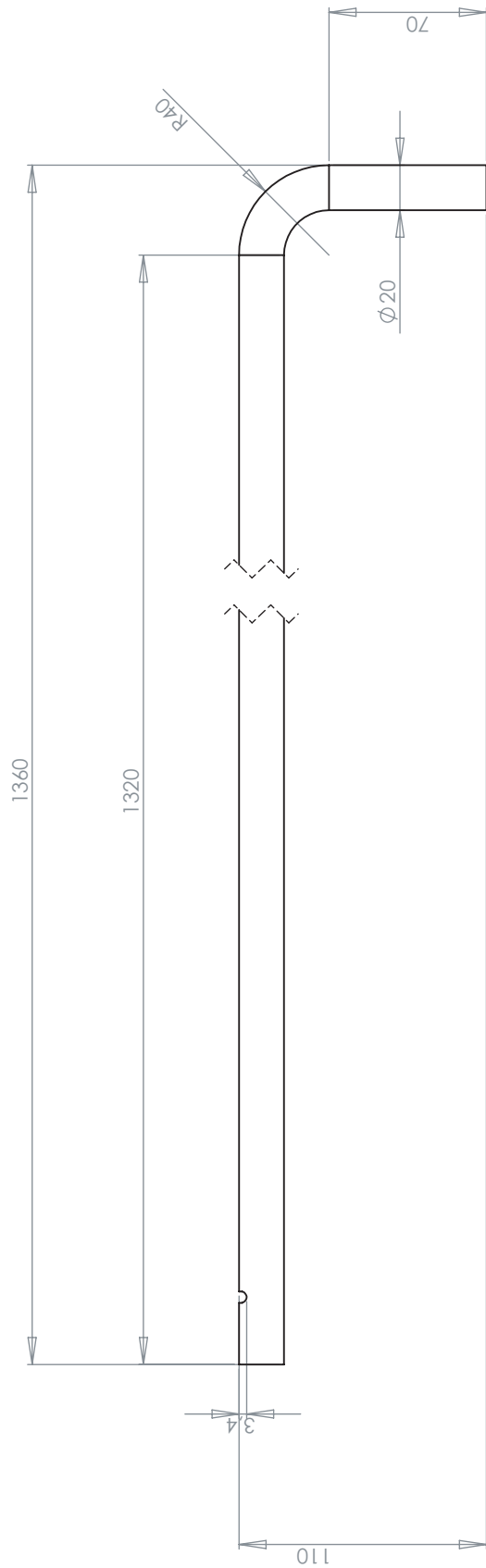
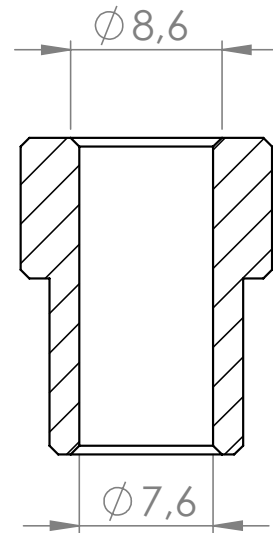
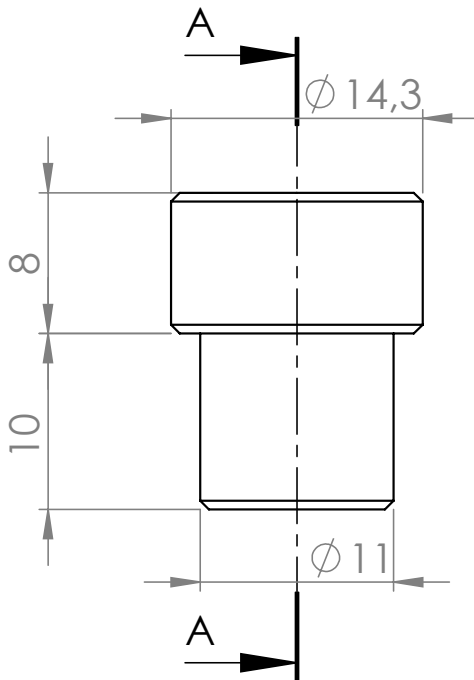
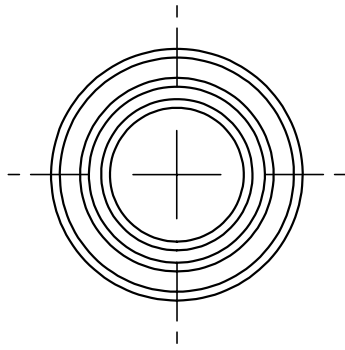

COUPE A-A

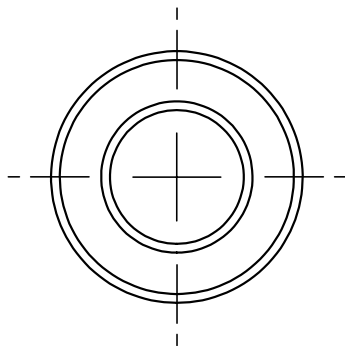

dcw.

Name : LAMP GRAS N°213

Matériaux : NYLON

Part : CENTRING PIECE

Date :

Rev : 1

Details :

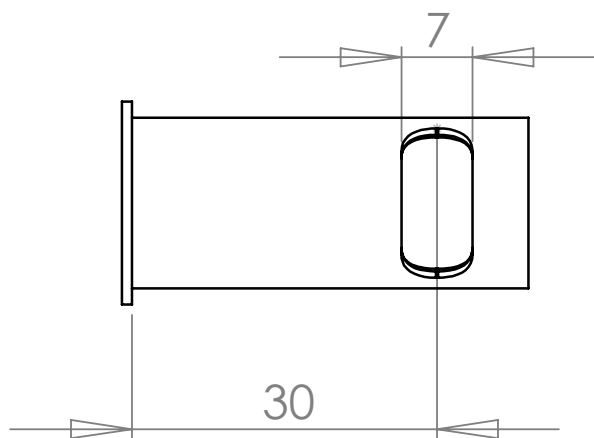
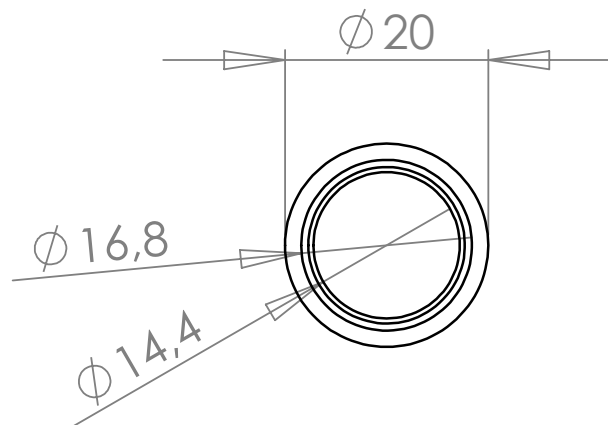
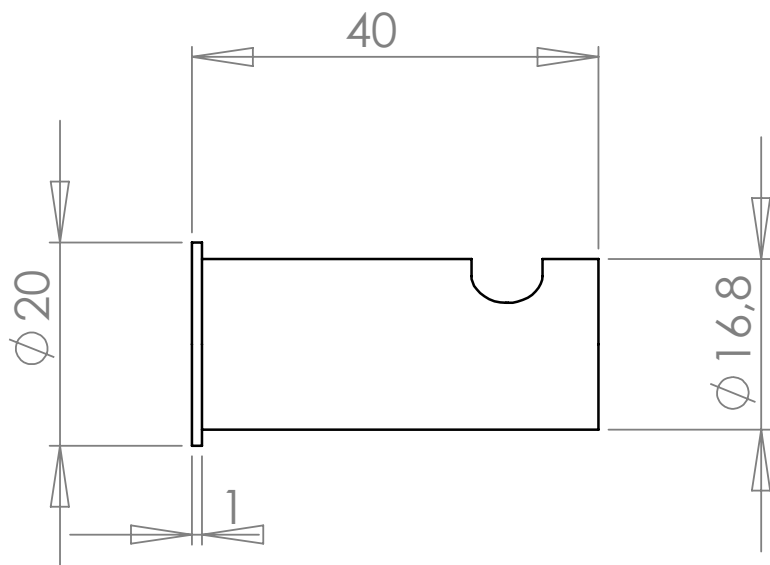

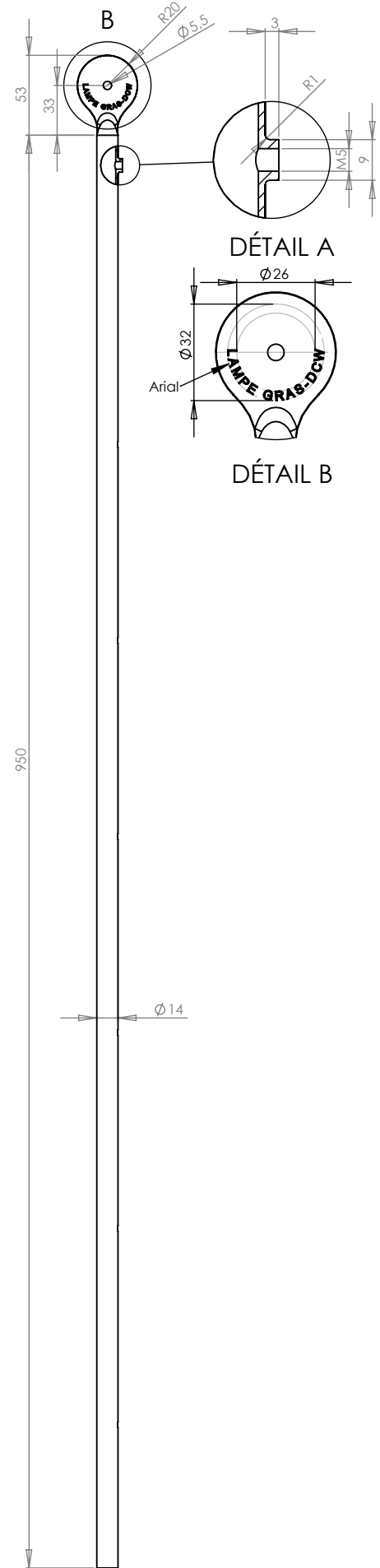
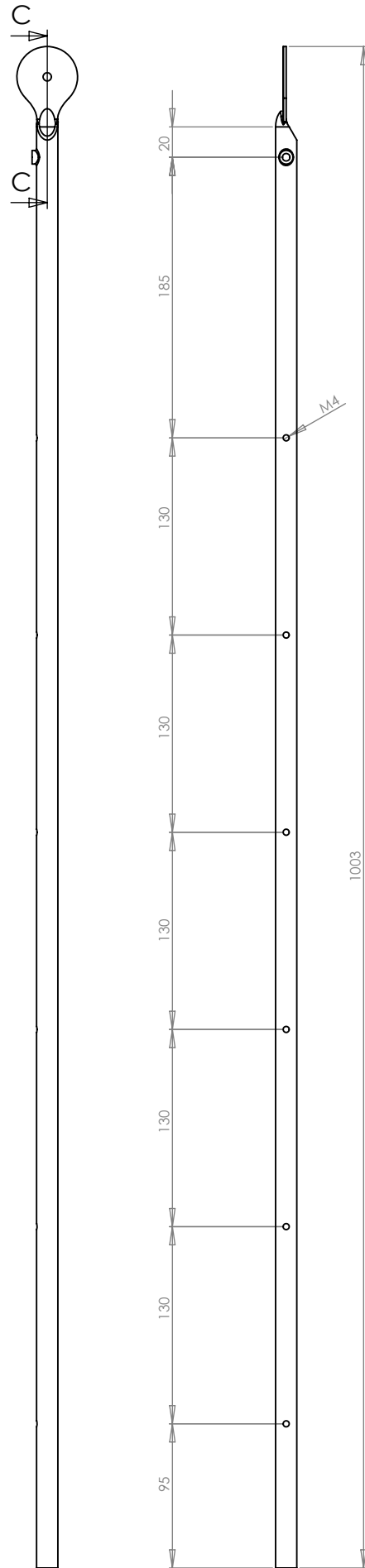
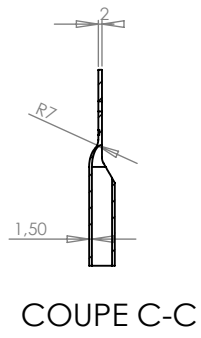

dcw.

Name : LAMP GRAS N213 L

Matériaux : PAINTED STEEL / CHROMED STEEL

Part : TUBE 1

Date :

Rev : 1

Details :

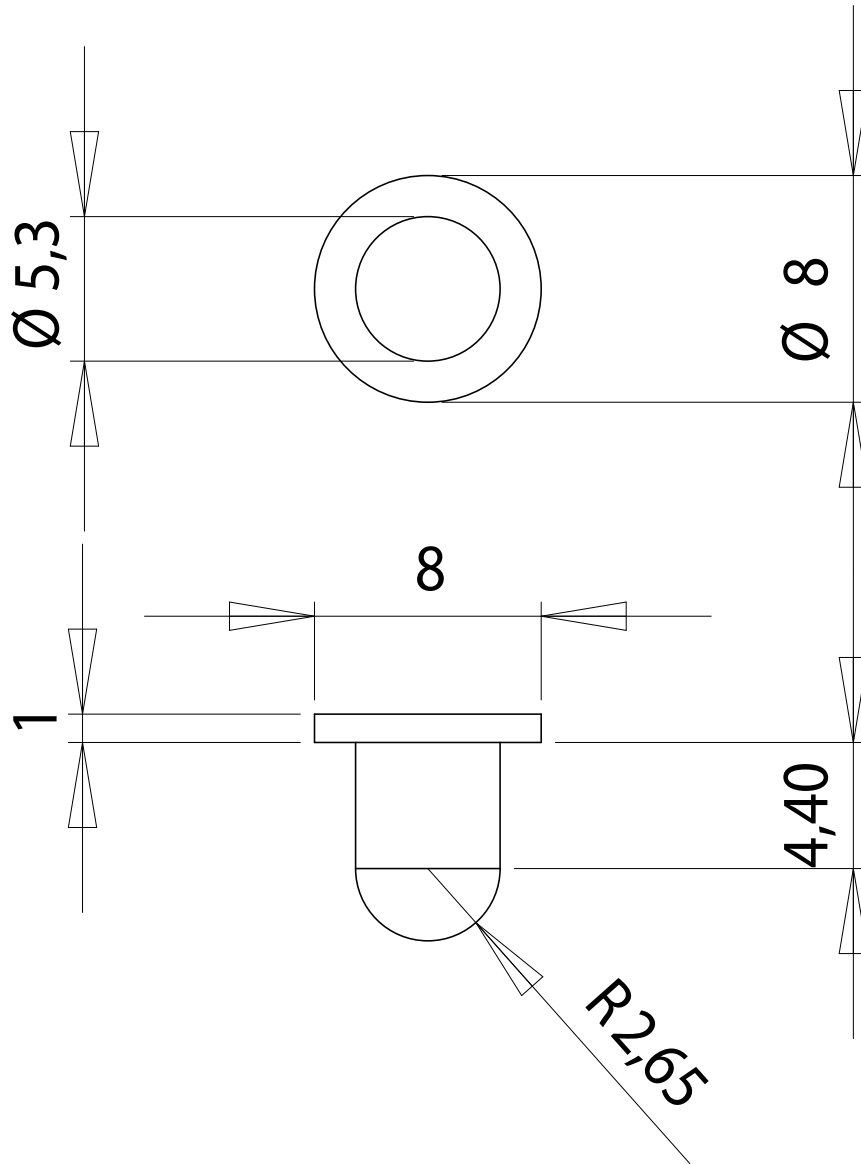

dcw.

Name : LAMP GRAS

Materials : CHROMED STEEL

Part : AXIS

Date :

Rev : 1

Details :

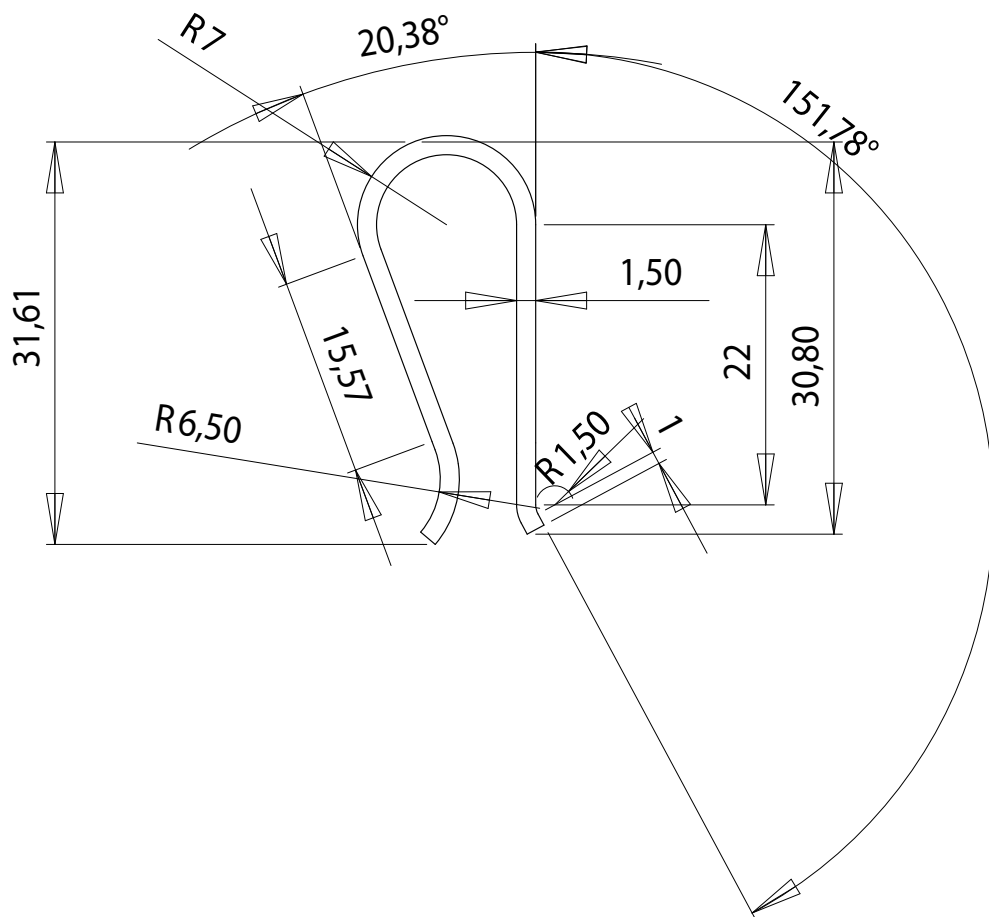
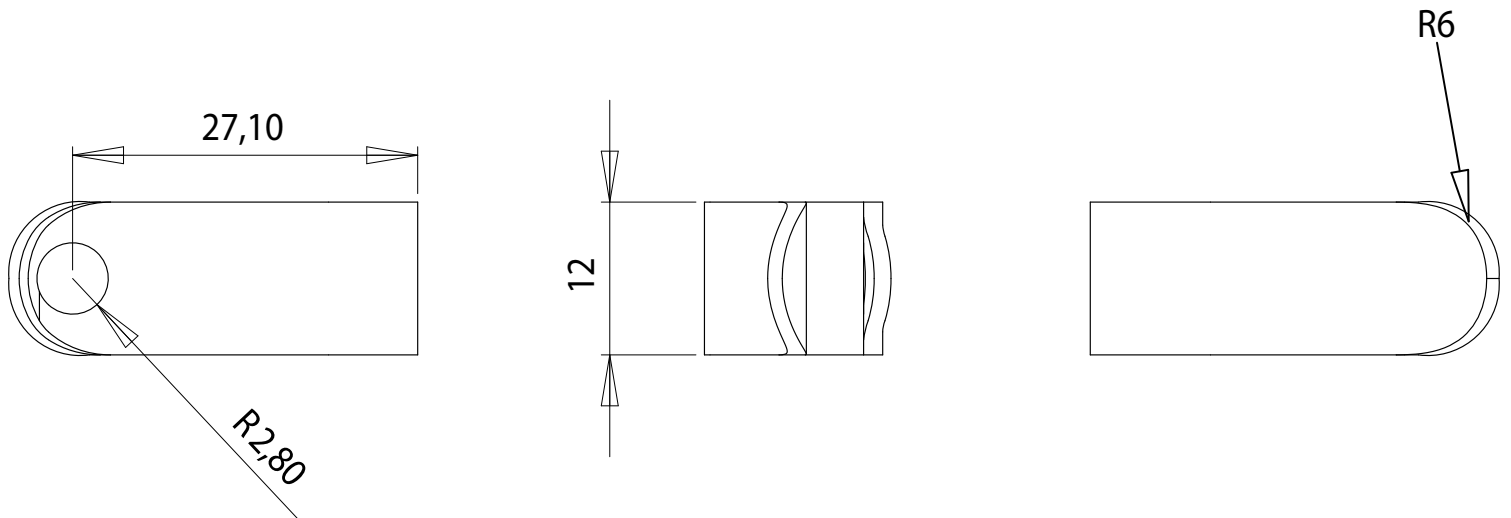

PLIERS SUPPLIED BY DCW

dcw.

Name : LAMP GRAS

Materials : SPRING CHROMED STEEL

Part : PLIERS

Date :

Rev : 1

Details :

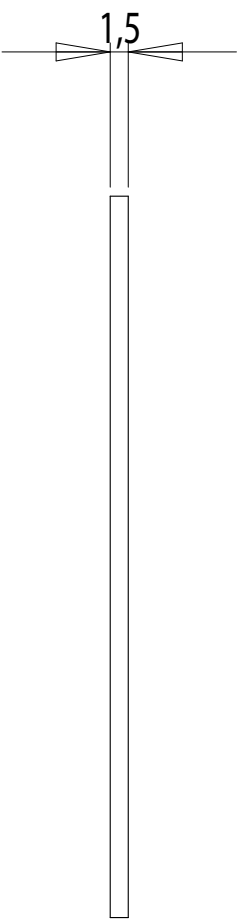
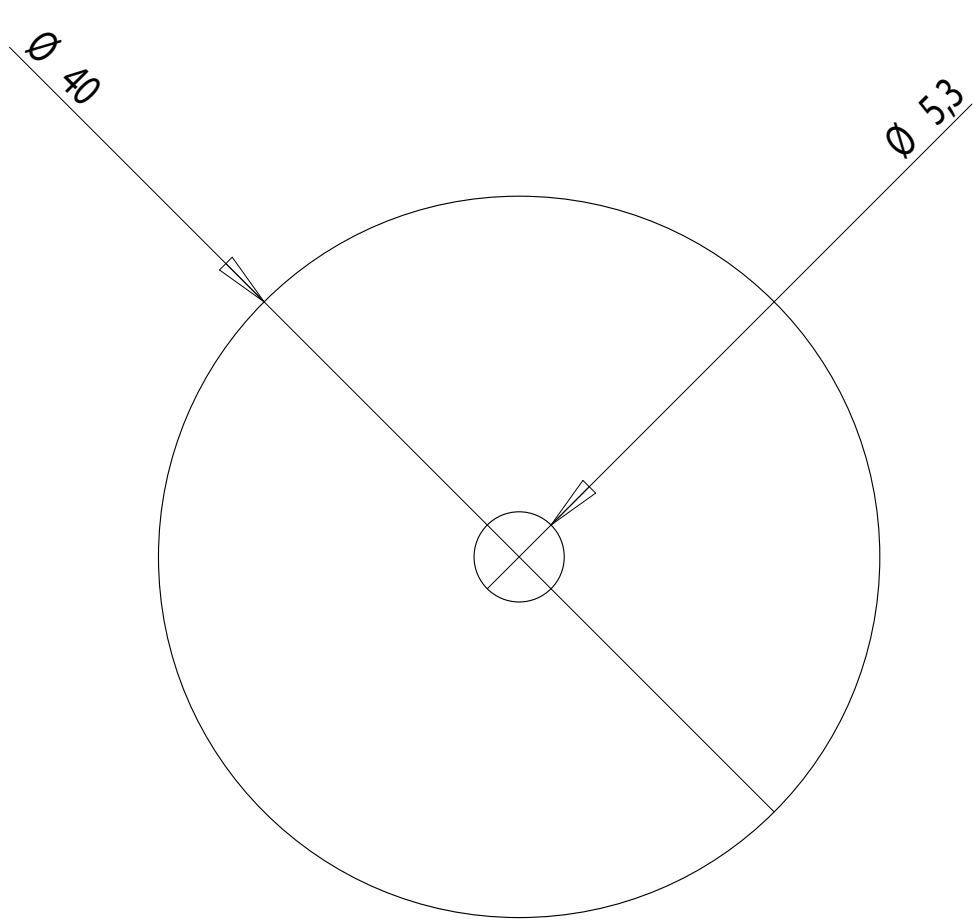

PLIERS SUPPLIED BY DCW

dcw.

Name : LAMP GRAS

Matériaux : PLASTIC

Part : PLASTIC WASHER – Ø40

Date :

Rev : 1

Details :

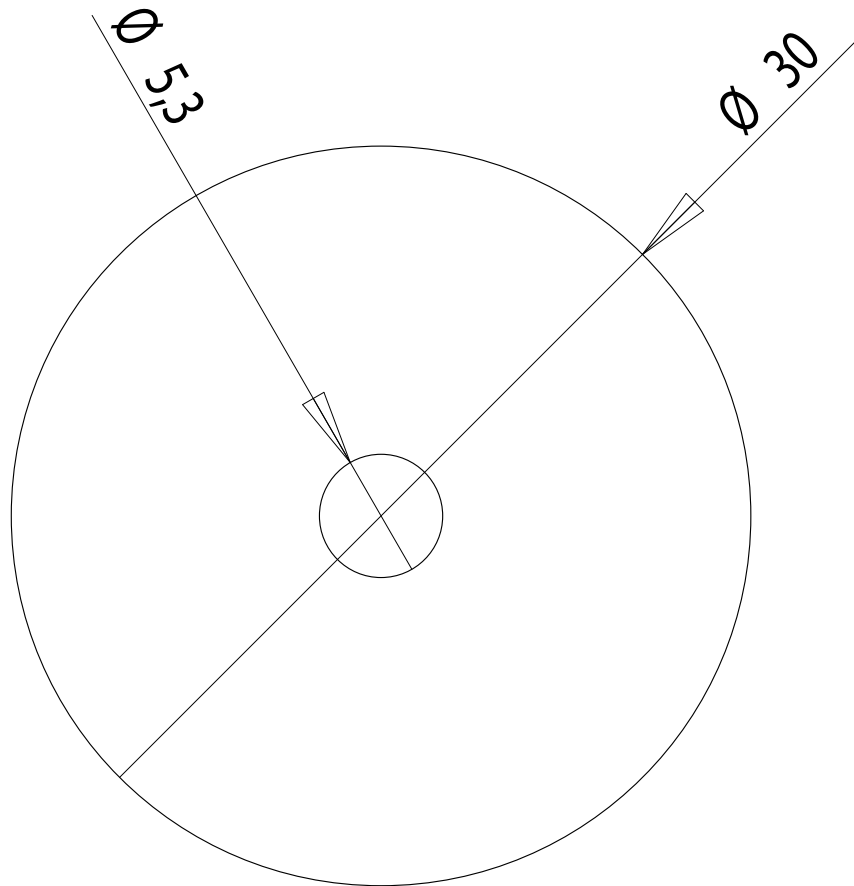
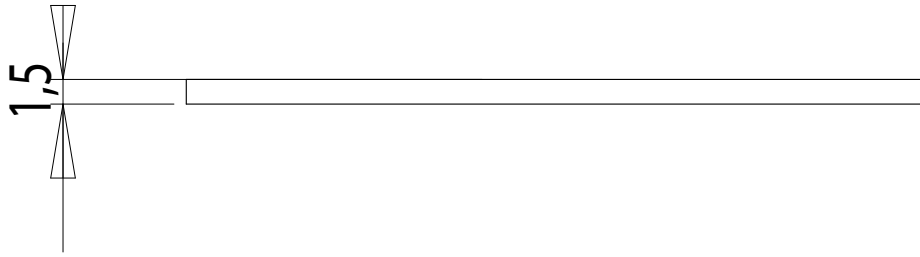

PLIERS SUPPLIED BY DCW

dcw.

Name : LAMP GRAS

Materials : PLASTIC

Part : PLASTIC WASHER – Ø30

Date :

Rev : 1

Details :

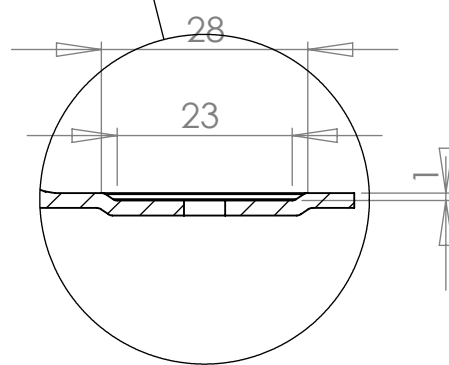
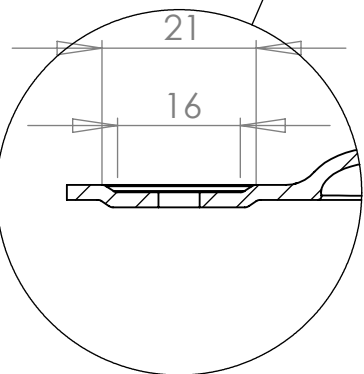
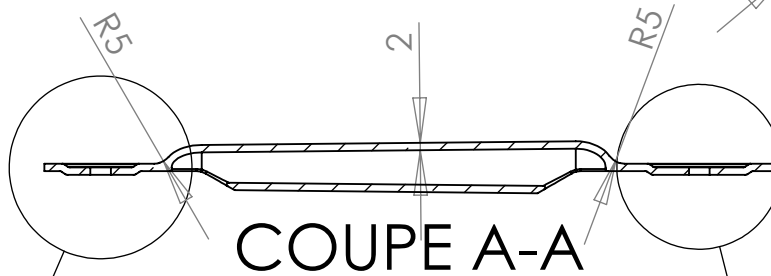
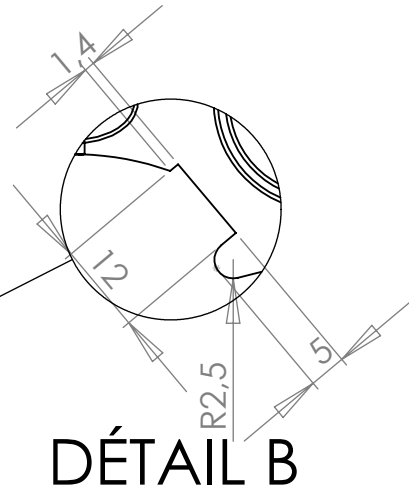
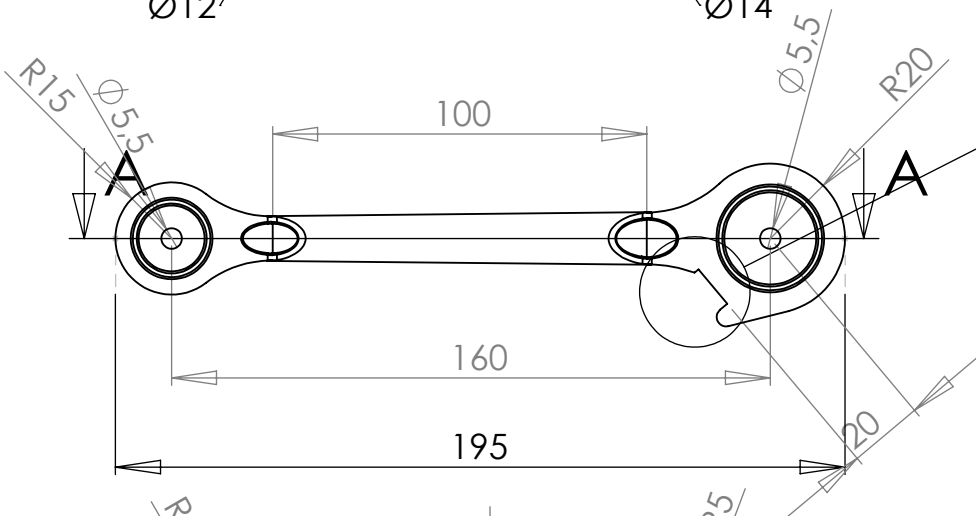
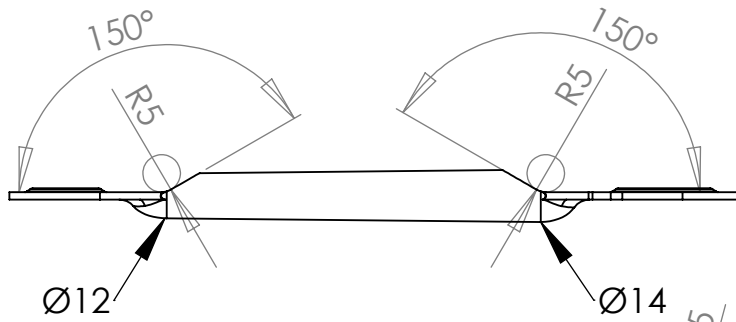
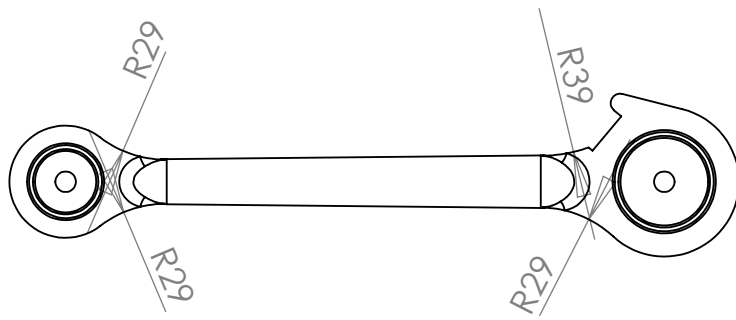

DÉTAIL C

DÉTAIL D

dcw.

Name : LAMP GRAS

Materials : PAINTED STEEL/CHROMED STEEL

Part : TUBE 2

Date : 16/12/2013

Rev : 1

Details :

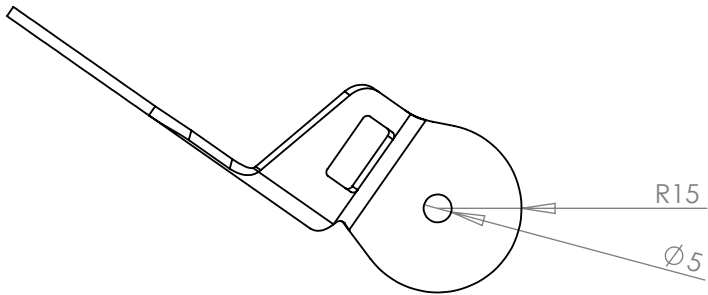
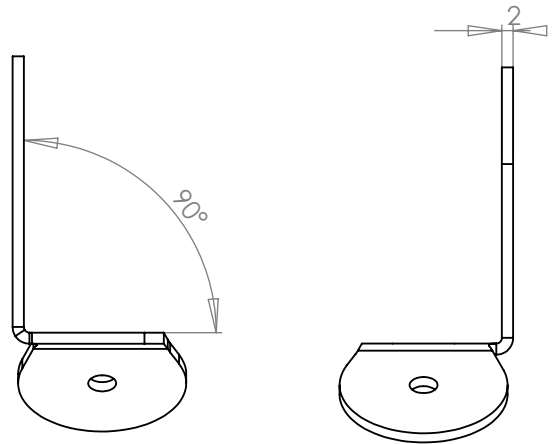
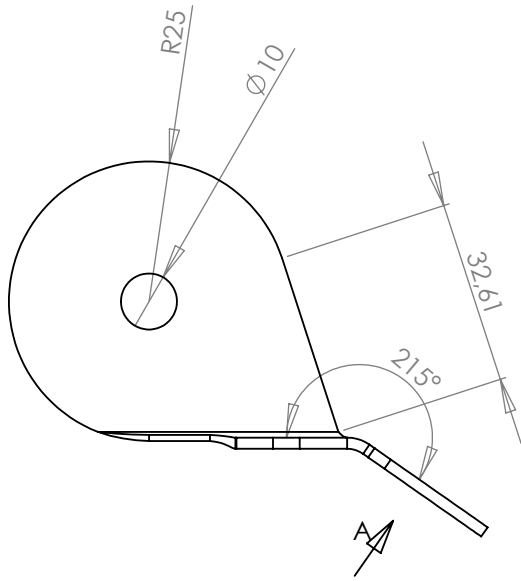
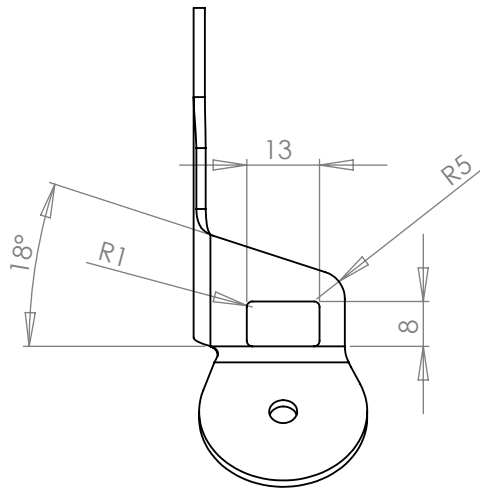

VUE A

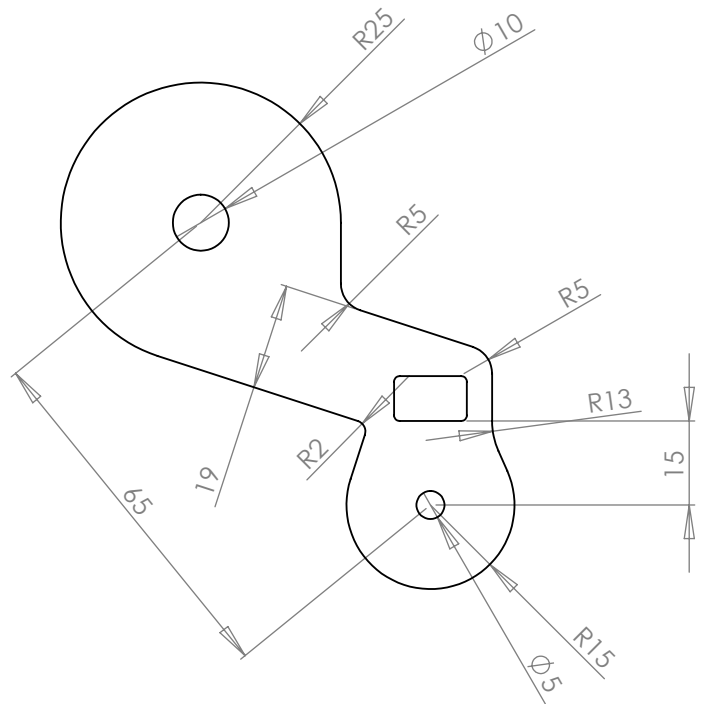

dcw.

Name : LAMP GRAS

Materials : PAINTED STEEL / CHROMED STEEL

Part : JUNCTION PIECE for E27

Date :

Rev : 1

Details :

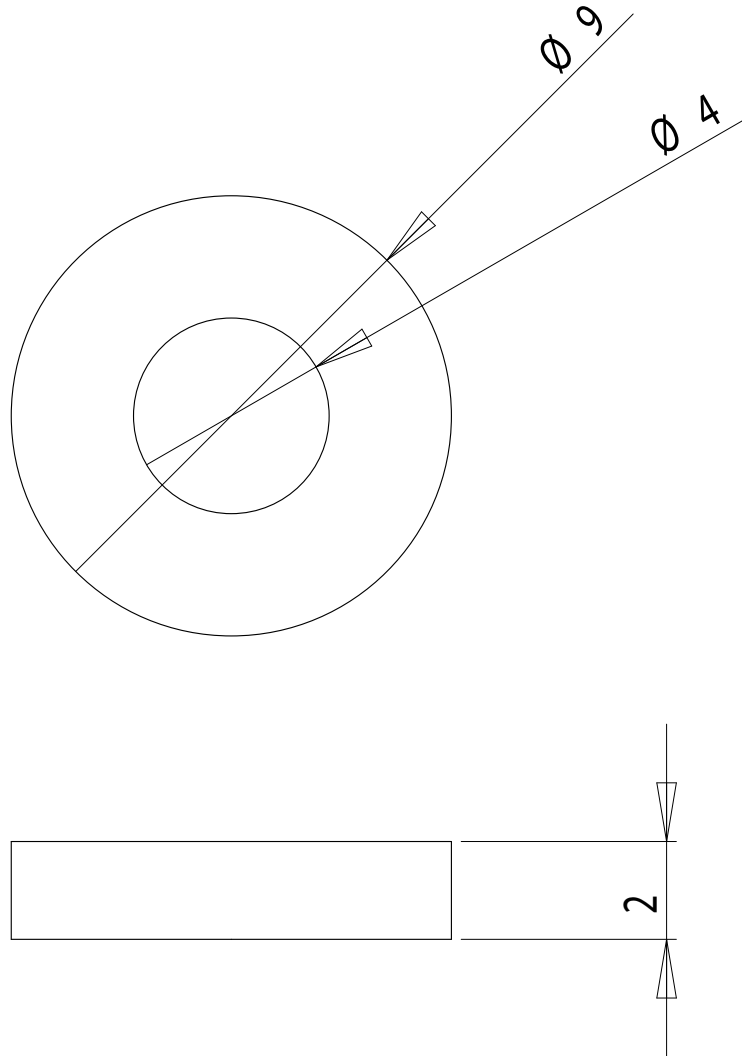

dcw.

Name : **LAMP GRAS**

Materials : PLASTIC

Part : **HANDLE WASHER**

Date :

Rev : 1

Details :

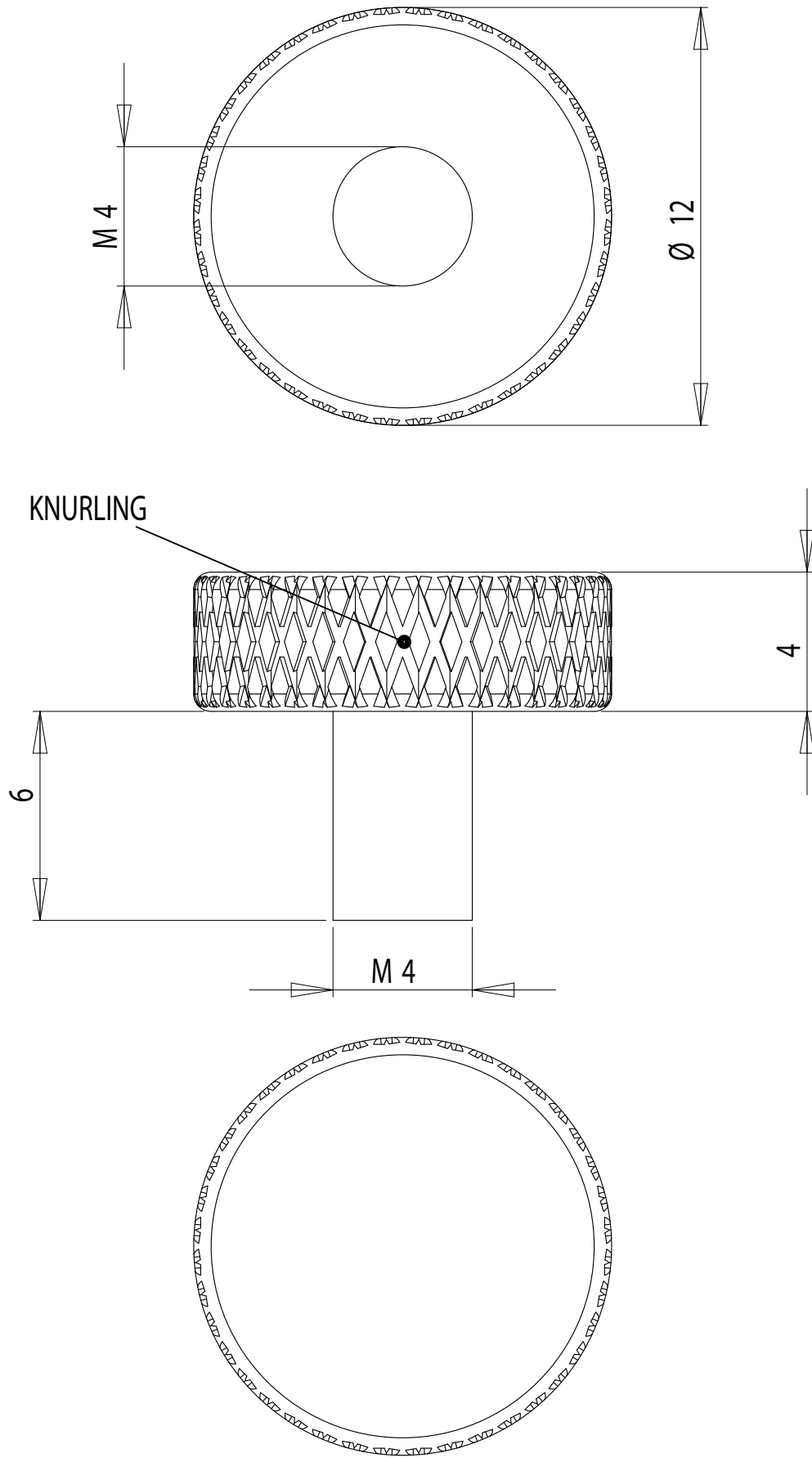

dcw.

Name : LAMP GRAS

Materials : PAINTED STEEL

Part : BREAKING HANDLE

Date :

Rev : 1

Details :

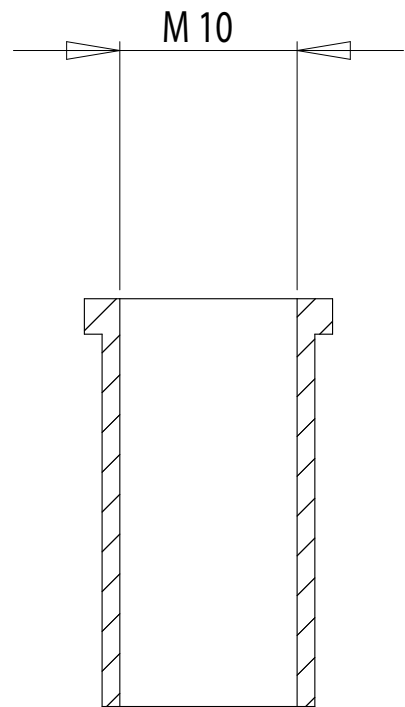
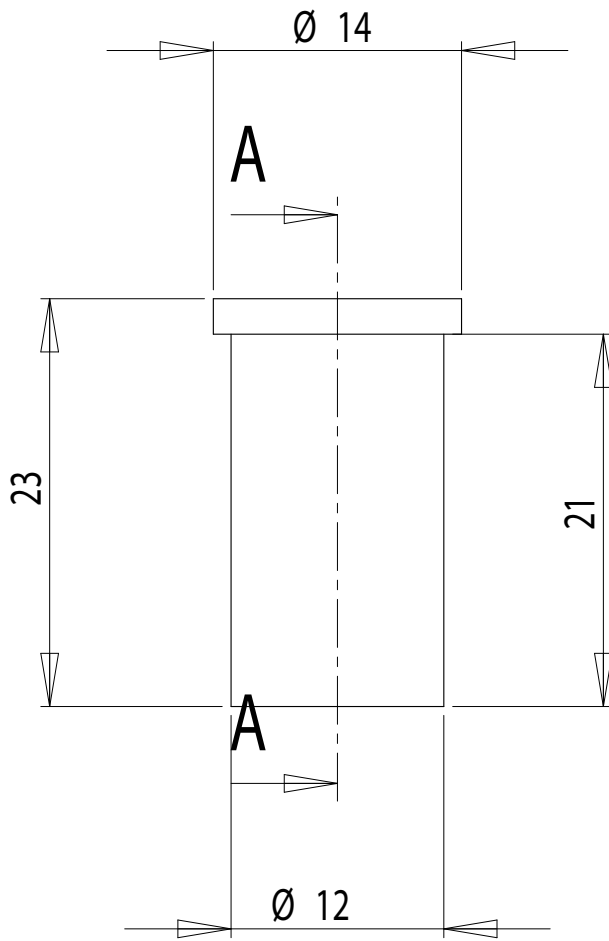

COUPE A-A

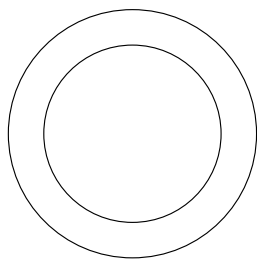

dcw.

Name : **LAMP GRAS**

Part : **FIXATION PIECE**

Date :

Rev : 1

Materials : PAINTED STEEL / CHROMED STEEL

Details :

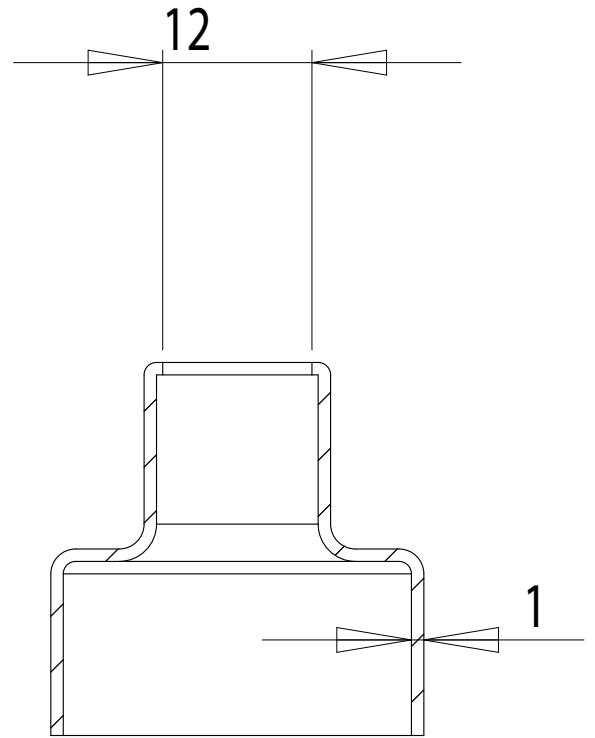
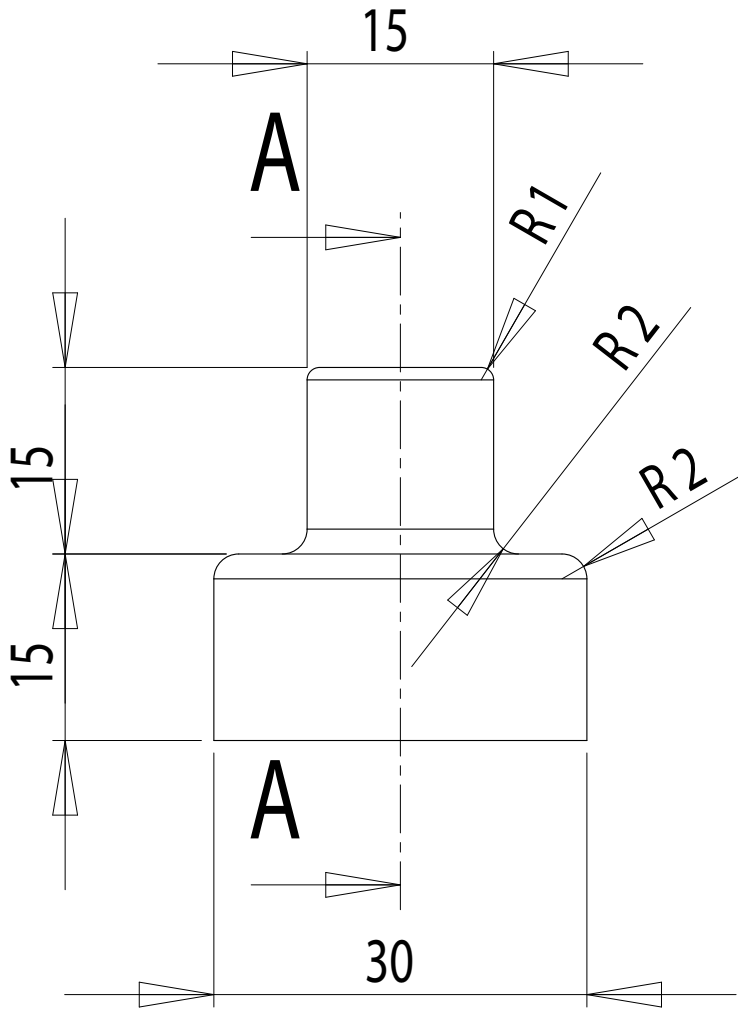

COUPE A-A

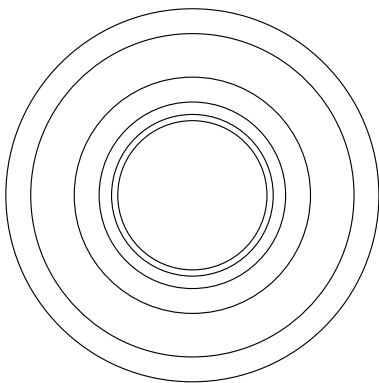

dcw.

Name : **LAMP GRAS**

Materials : PAINTED STEEL / CHROMED STEEL

Part : **COVERING PIECE**

Date :

Rev : 1

Details :

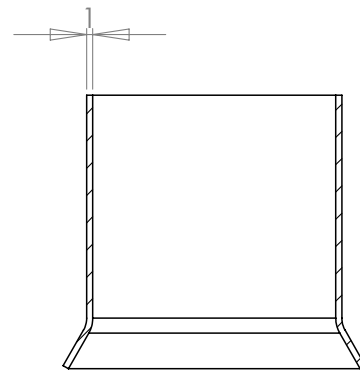
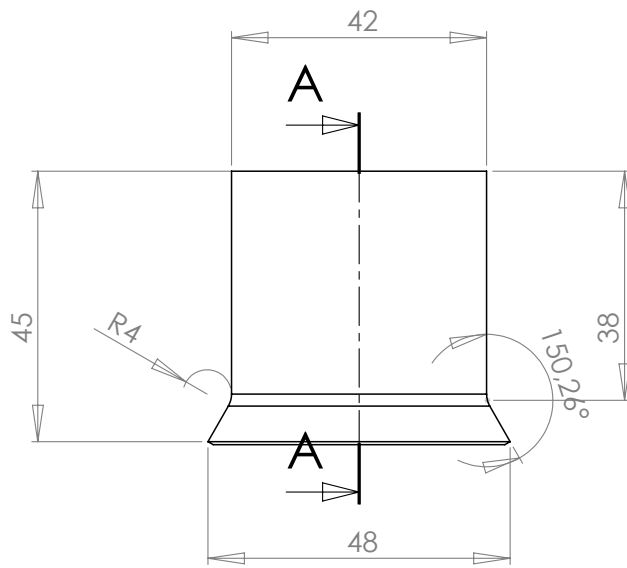
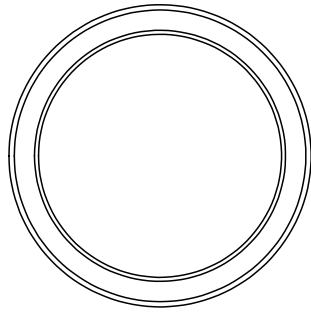

COUPE A-A

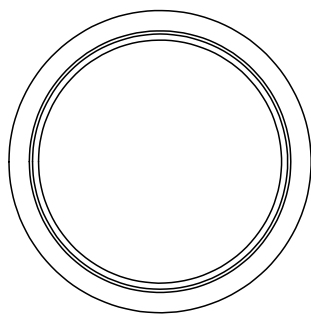

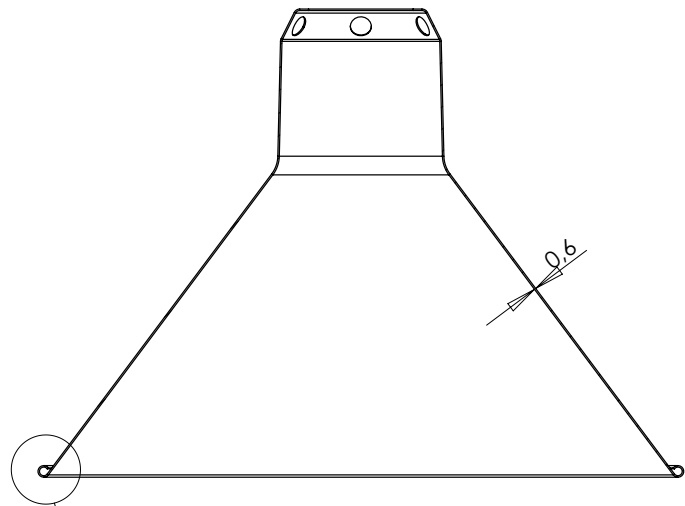
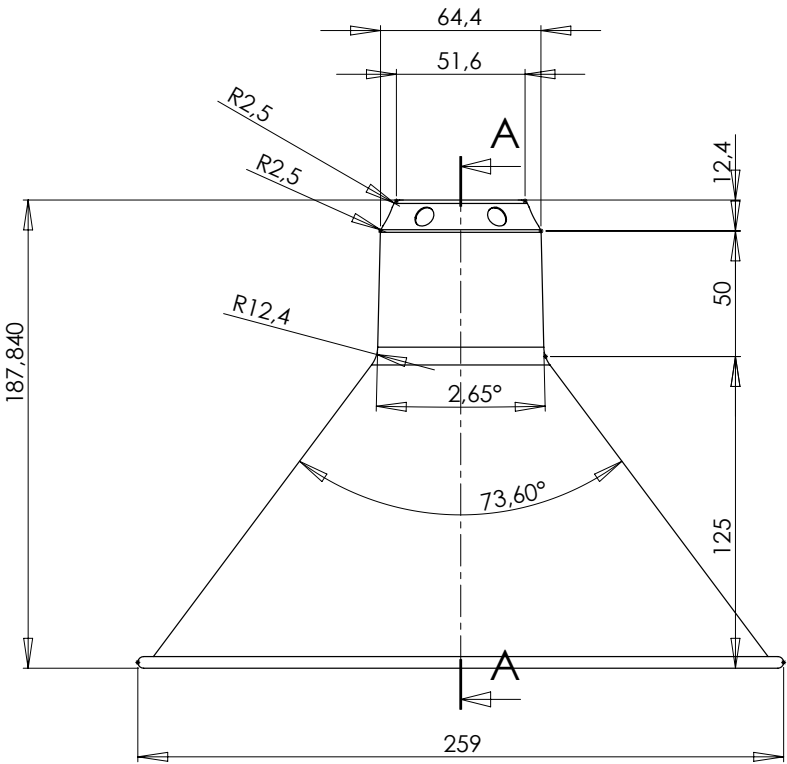

COUPE A-A

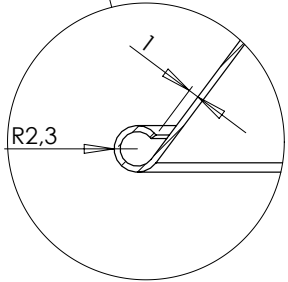

DÉTAIL B

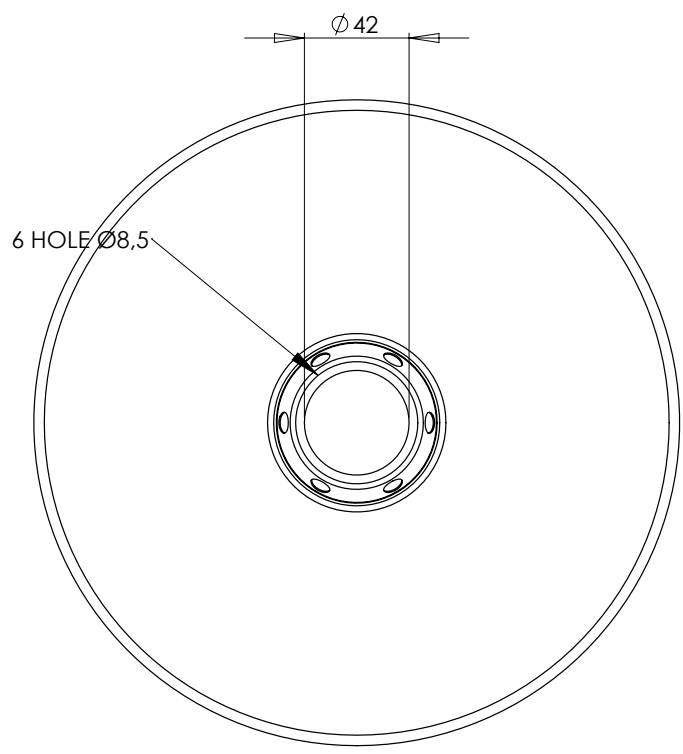

RANGE : LAMPE GRAS	REF :	MATERIAL/FINISHING : PAINTED STEEL - WHITE INSIDE
PART : CONIC SHADE LARGE		
REV N° : 2		