

Qty	Piece	Finishing			
1	COVER	BLACK SATIN	1	TUBE 2	BLACK SATIN
1	WEIGHT	BLACK SATIN	1	JUNCTION PIECE	BLACK SATIN
1	BASE	BLACK SATIN	1	COVERING PIECE	BLACK SATIN
1	BASE PART 2	BLACK SATIN	1	FIXATION PIECE	CHROME
1	BASE PART 3	BLACK SATIN	1	CYLINDER SHADE	BLACK OUTSIDE / WHITE INSIDE
1	CAST SPRING		1	BULBHOLDER SPACER	
1	BALL BREAKER		1	BULBHOLDER SCREW	
1	SPHERE	BLACK	1	BULBHOLDER	
1	RUBBER	BLACK	4	M3 x 4 SCREW	
1	BREAKING HANDLE	BLACK SATIN	5	M10 x 4 NUT	
1	TUBE 1	BLACK SATIN	1	M5 x 10 PLASTIC SCREW	
1	PLASTIC WASHER Ø40	RED	1	THREAD 10X100	
1	PLASTIC WAHSER Ø30	RED			
2	PLIERS	CHROME			

dcw.

Name : LAMP GRAS N°230 BL-SAT

Materials :

Part :

Date : (%\$) \$ %&

Rev : 1

Details : E14 - 11w ; Arditi métal bulbholder ; Switch on wire ;  
Black fabric wire

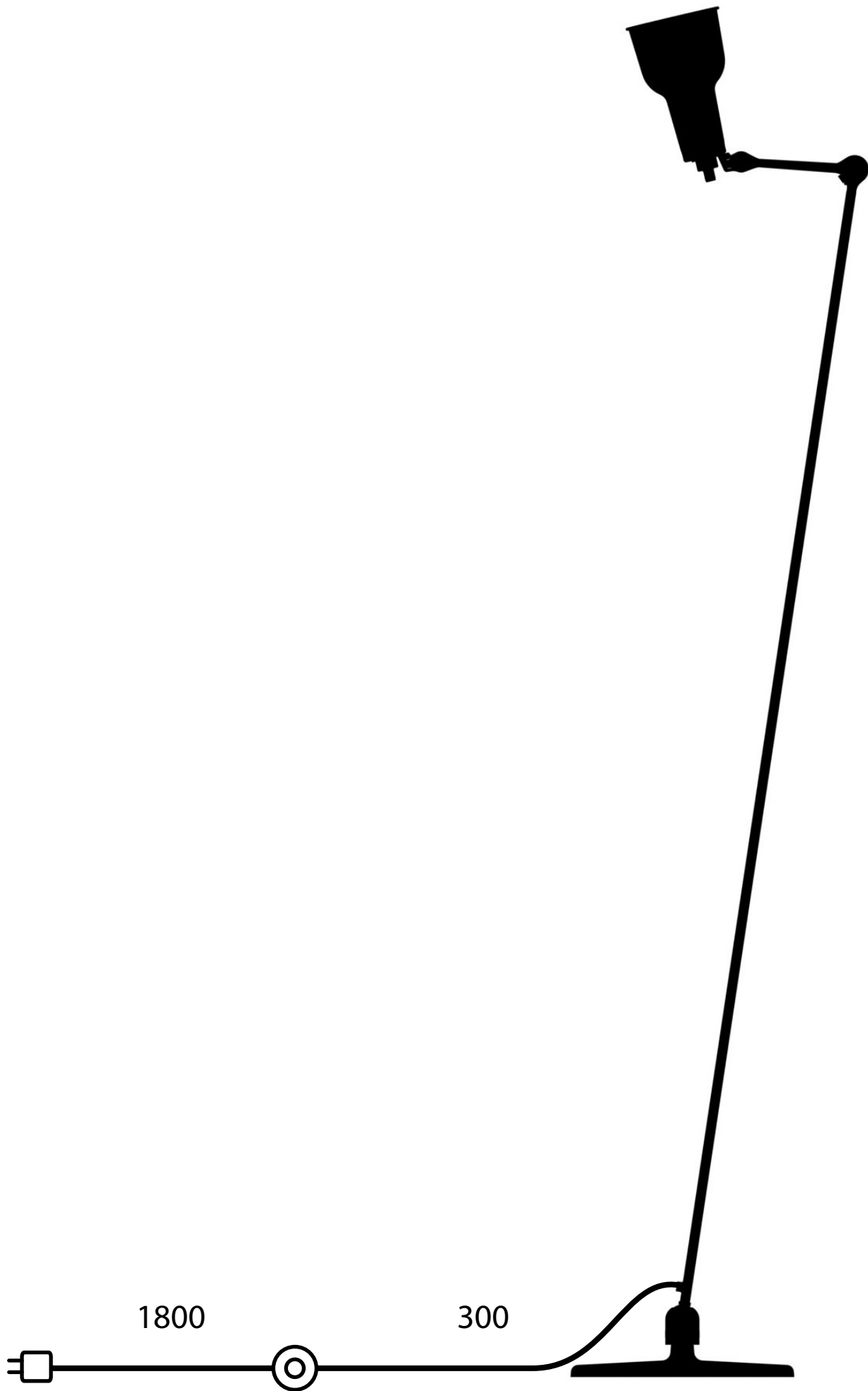

dcw.

Name : LAMP GRAS N°230

Matériaux :

Part :

Date :

Rev : 1

Details :

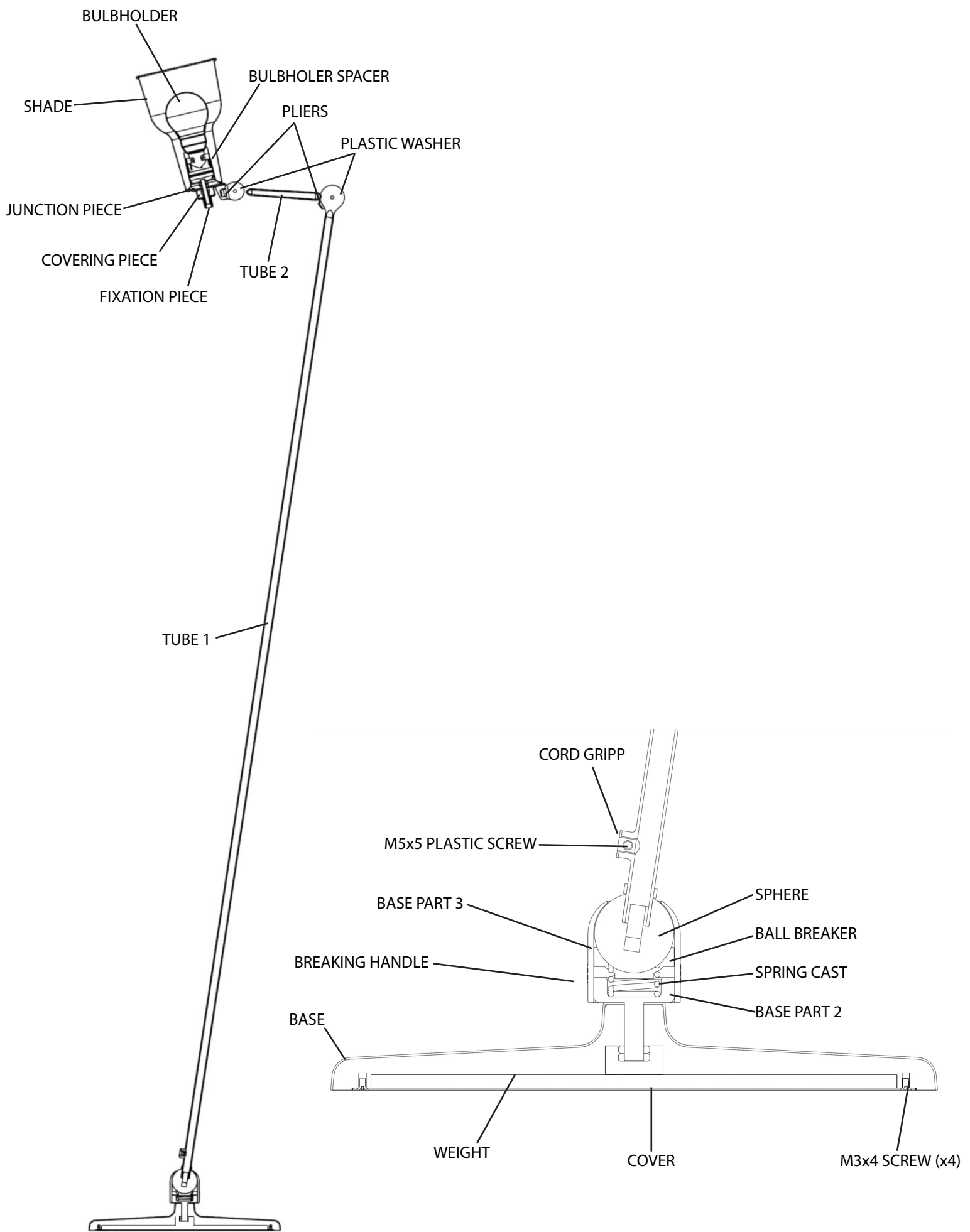

dcw.

Name : LAMP GRAS N°230

Part : ELEMENTS

Date :

Rev : 1

Matériaux :

Détails :

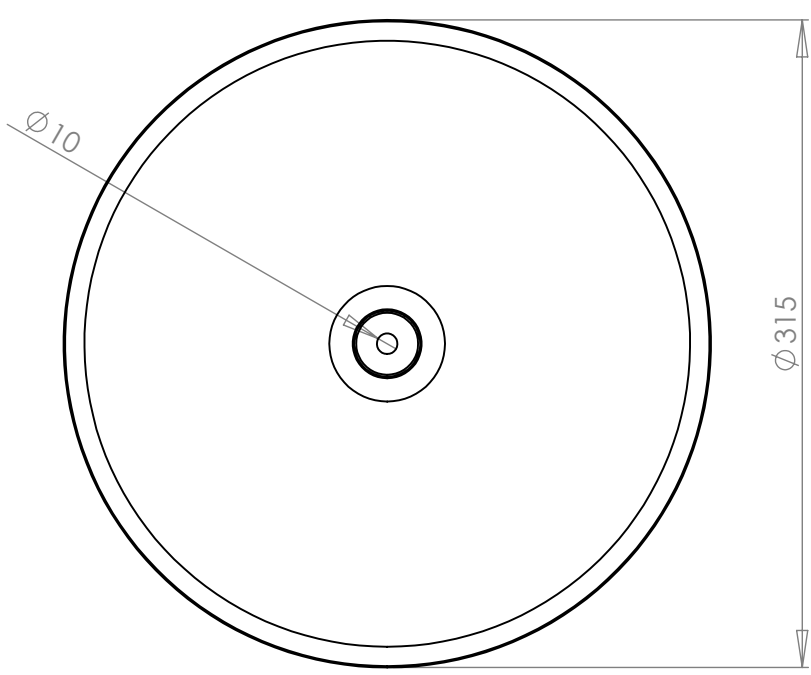
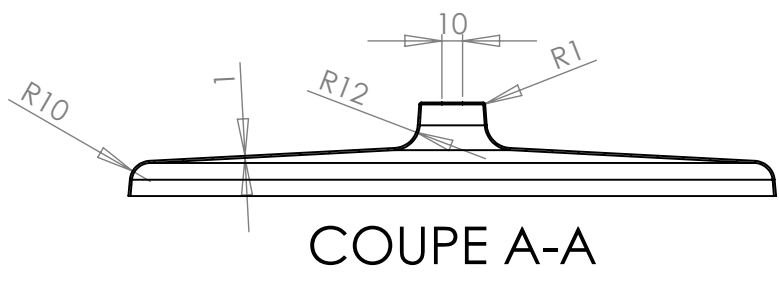
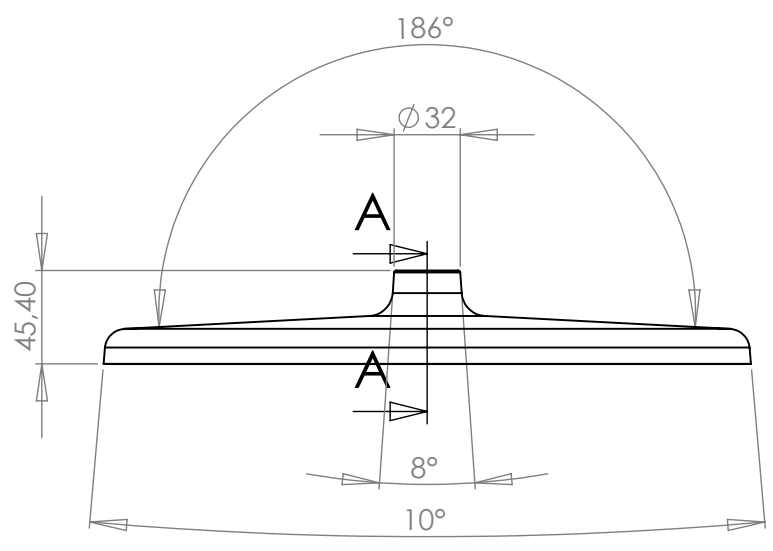

dcw.

Name : LAMP GRAS N°230

Materials : PAINTED STEEL

Part : BASE

Date :

Rev : 1

Details :

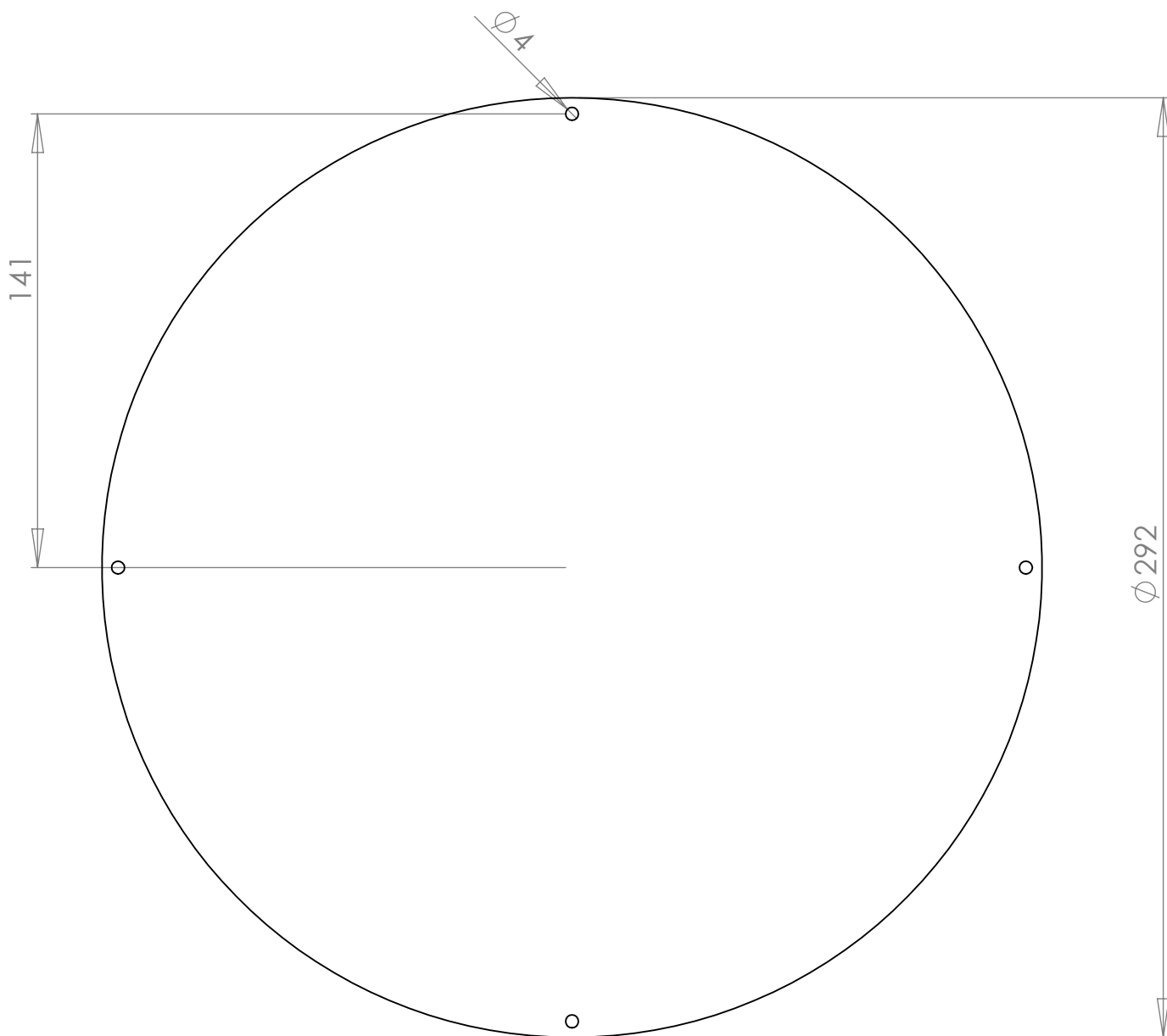
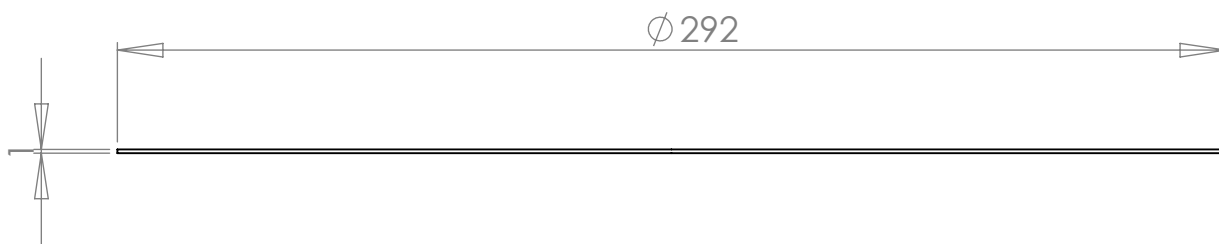

dcw.

Name : LAMP GRAS N°230

Materials : PAINTED STEEL

Part : COVER

Date :

Rev : 1

Details :

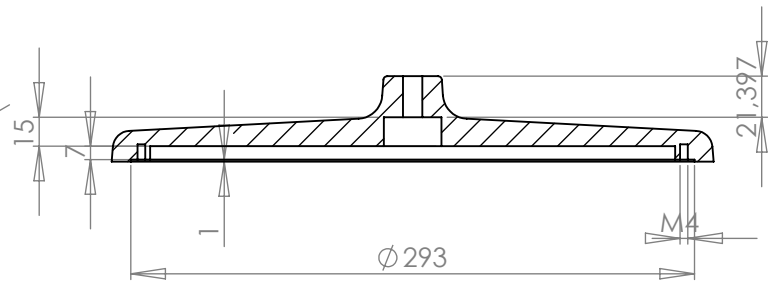
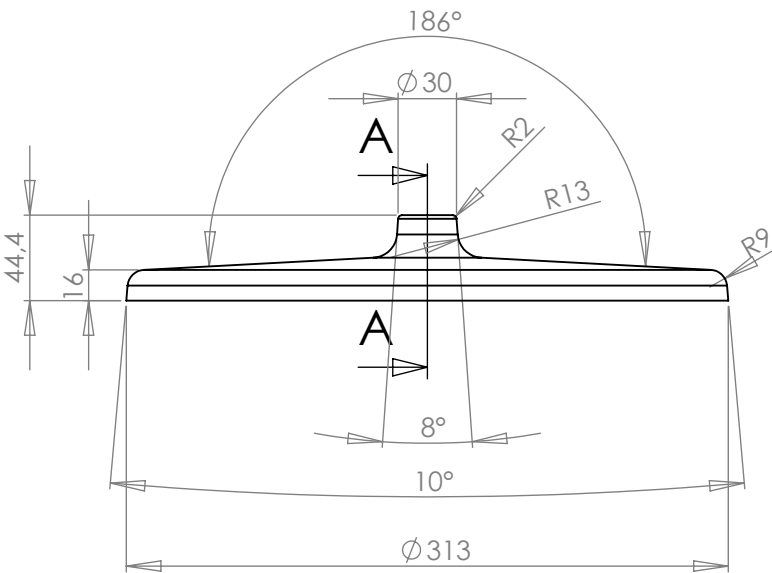
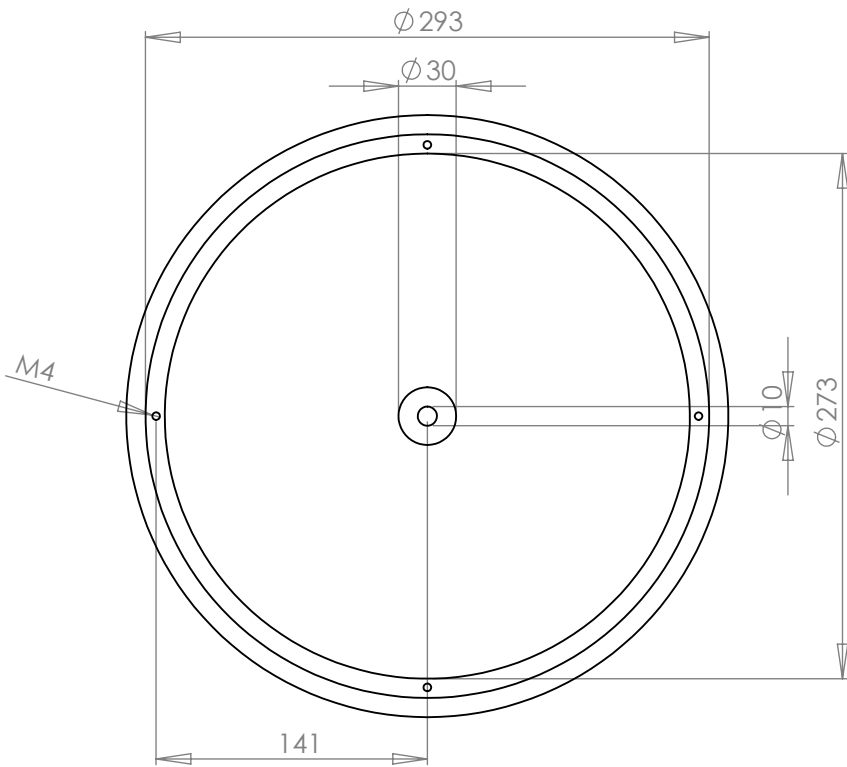

COUPE A-A

dcw.

Name : LAMP GRAS N°230

Matériaux : PAINTED STEEL

Part : WEIGHT

Date :

Rev : 1

Details :

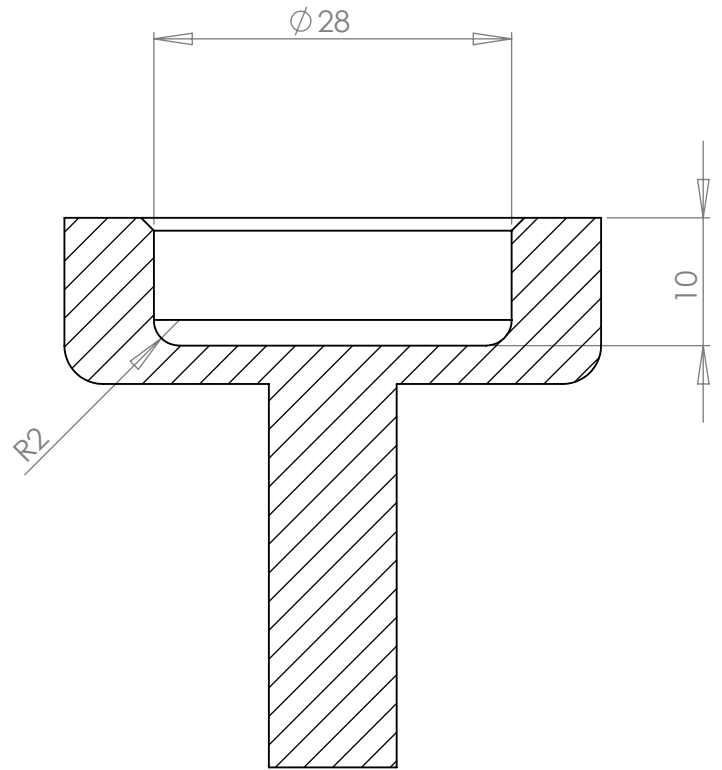
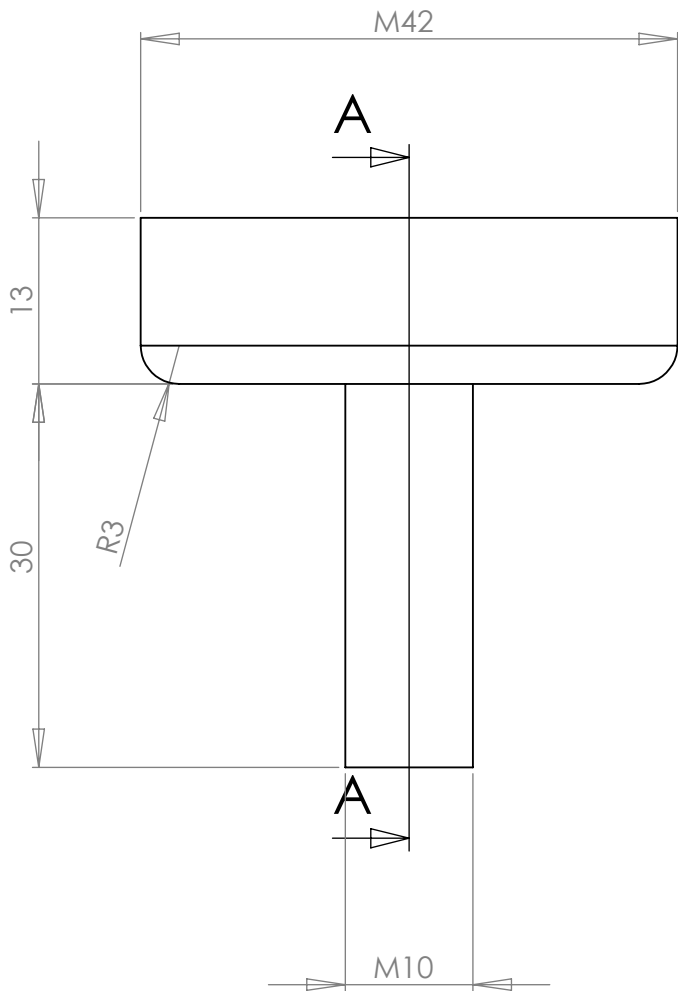
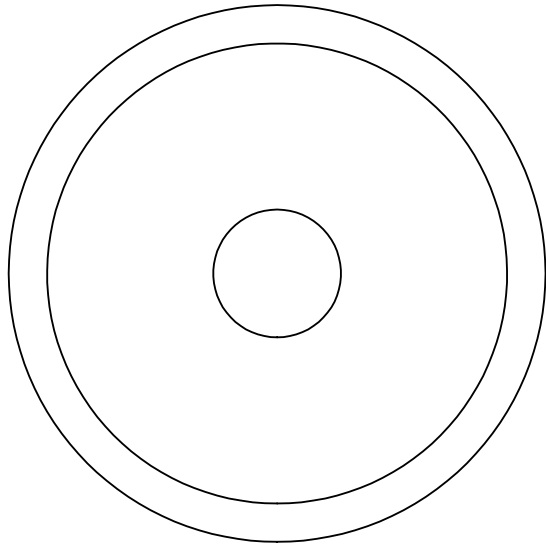

COUPE A-A

dcw.

Name : LAMP GRAS N°230

Materials : PAINTED STEEL

Part : BASE PART 2

Date :

Rev : 1

Details :

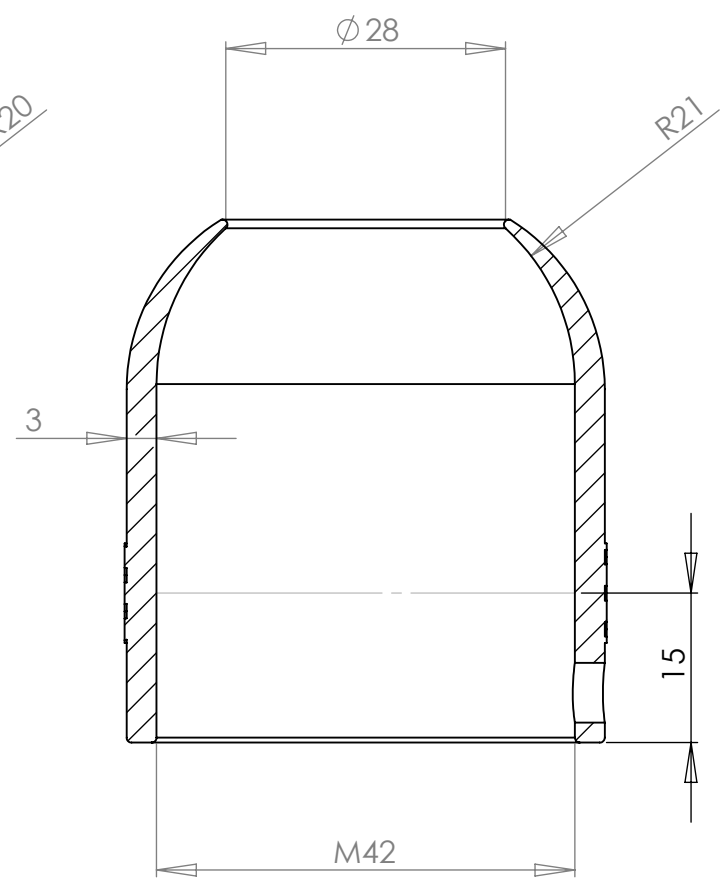
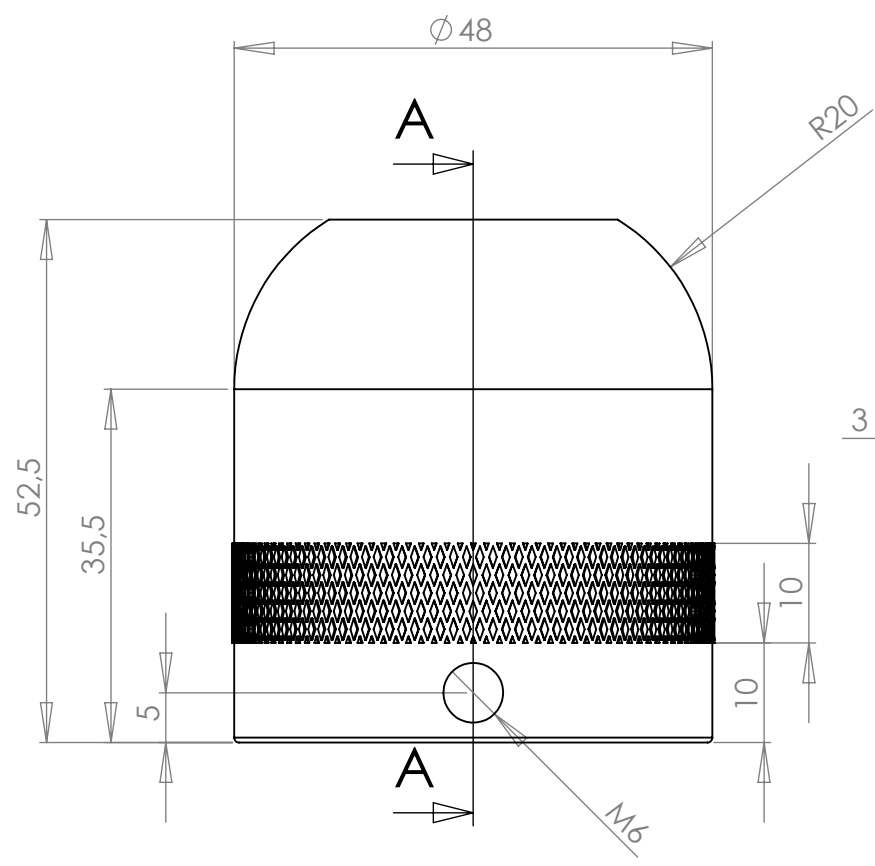

COUPE A-A

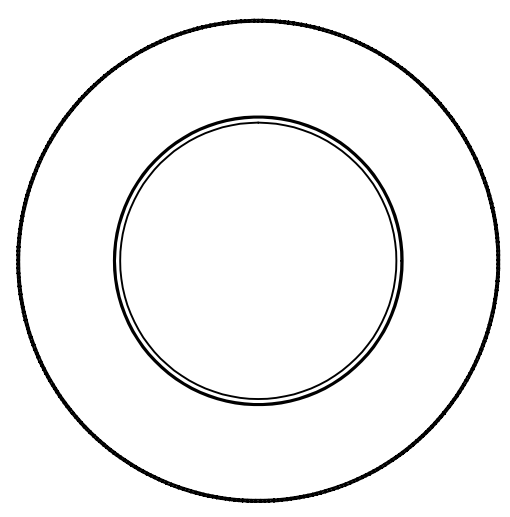

dcw.

Name : LAMP GRAS N°230

Matériaux : PAINTED STEEL

Part : BASE PART 3

Date :

Rev : 1

Details :

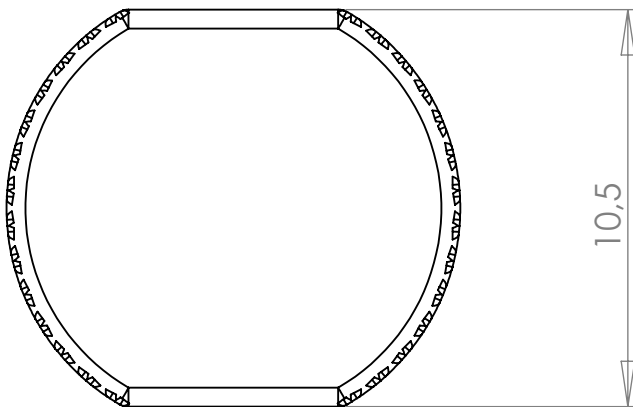
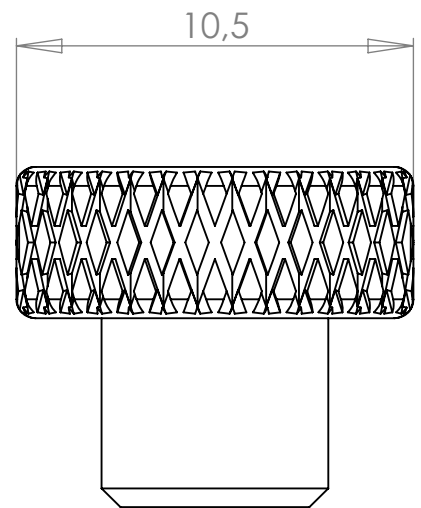
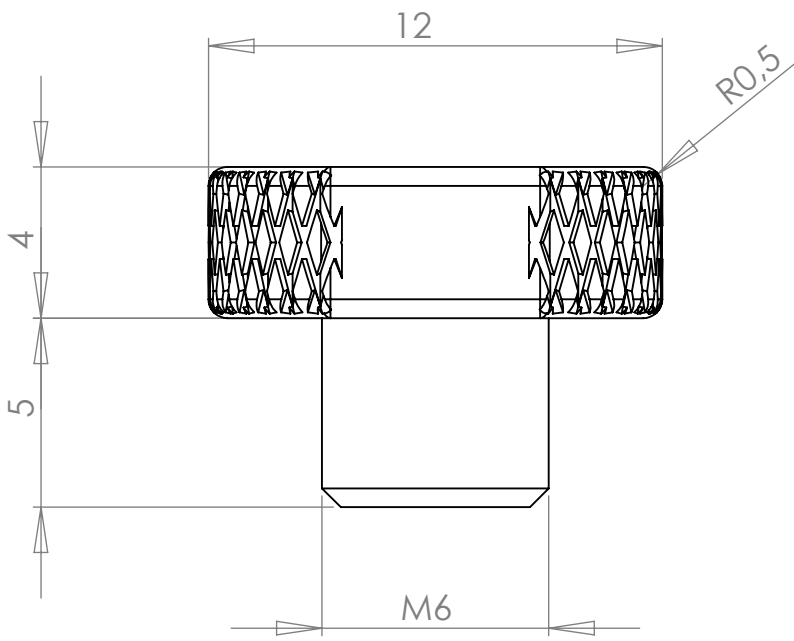
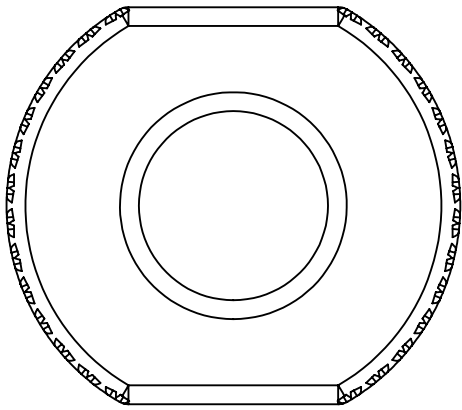

dcw.

Name : LAMP GRAS N°302/304

Materials : PAINTED STEEL

Part : BREAKING HANDLE

Date :

Rev : 2

Details :

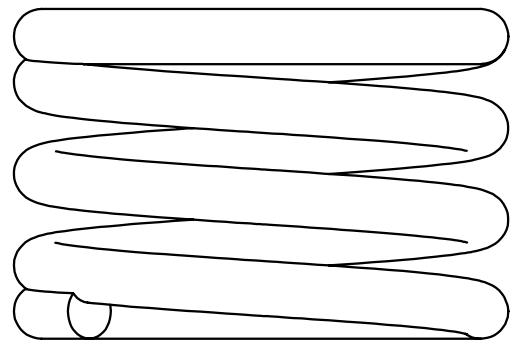
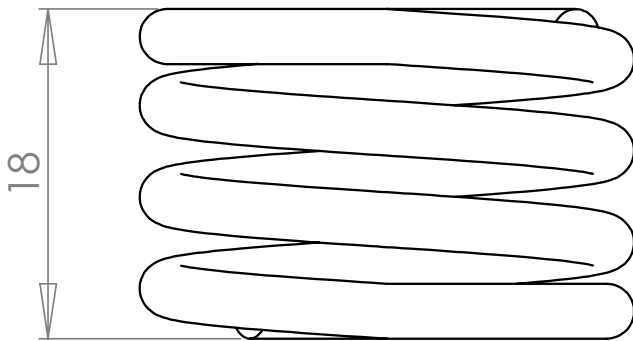
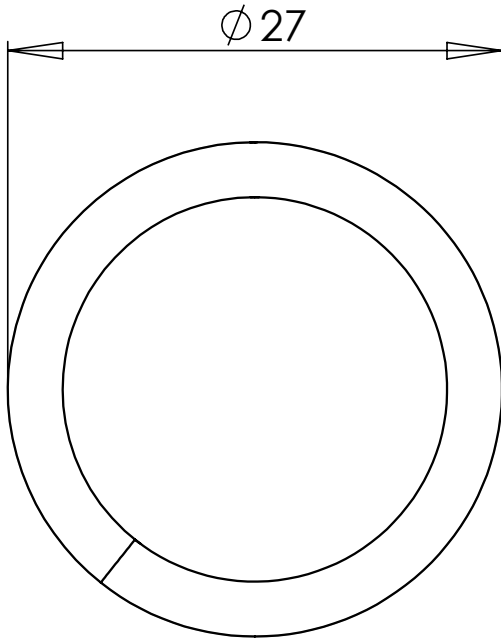

dcw.

Name : LAMP GRAS

Matérials : SPRING STEEL

Part : CAST SPRING

Date :

Rev : 1

Details :

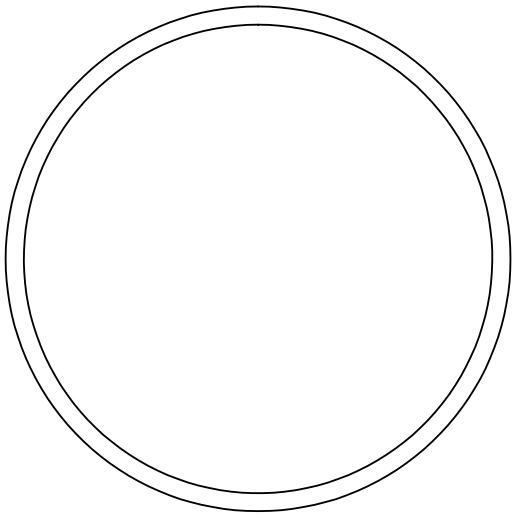
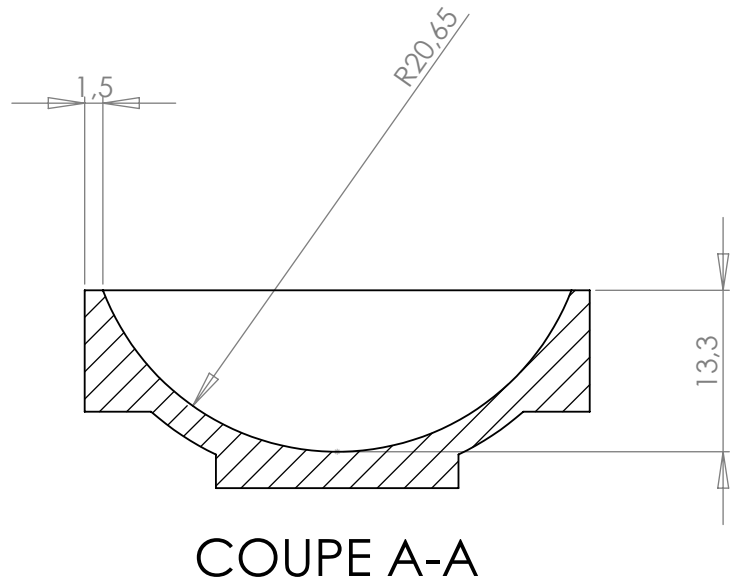
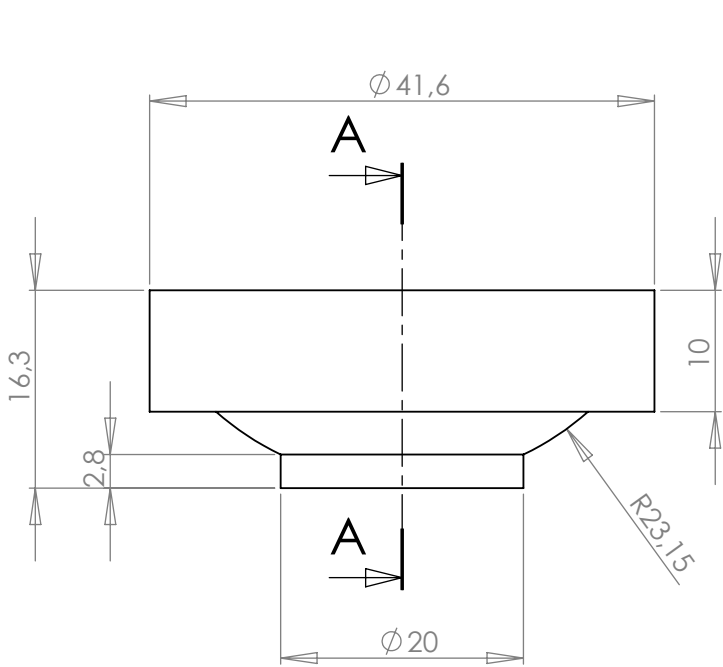

dcw.

Name : **LAMP GRAS**

Matériaux : BRASS

Part : **BALL BREAKER**

Date :

Rev : 1

Details :

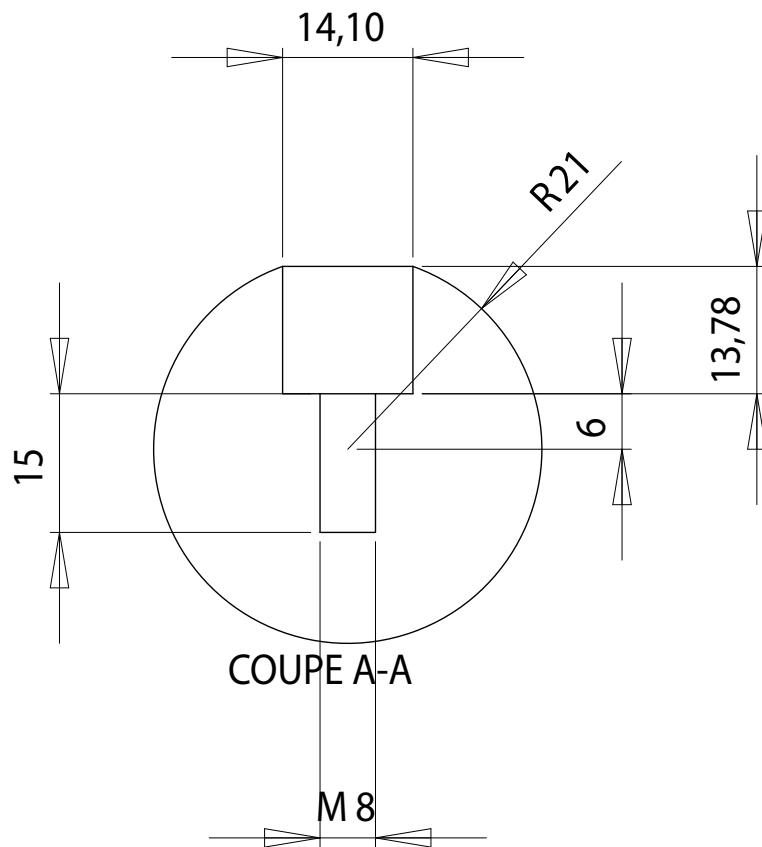
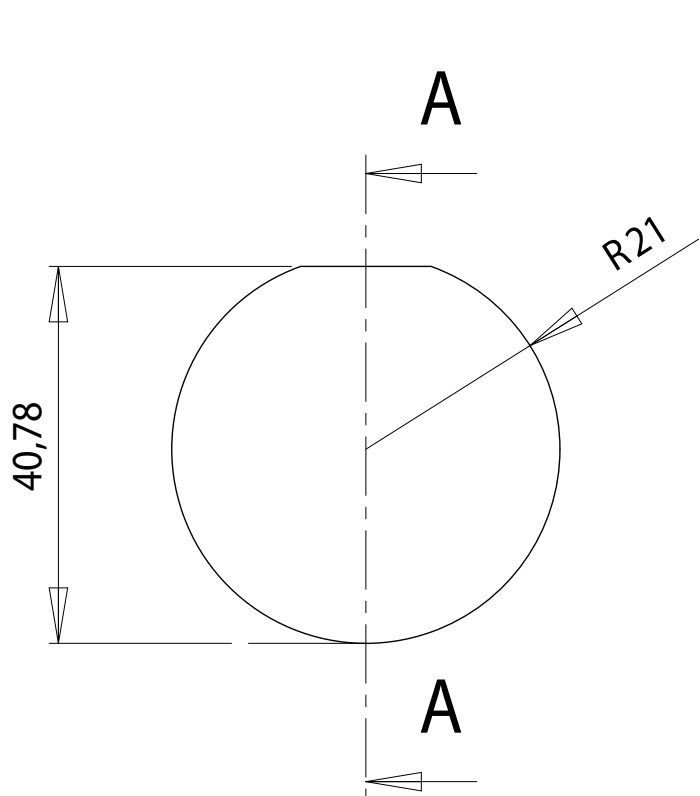

dcw.

Name : LAMP GRAS

Matériaux : BLACK BAKELITE

Part : SPHERE

Date :

Rev : 1

Details :

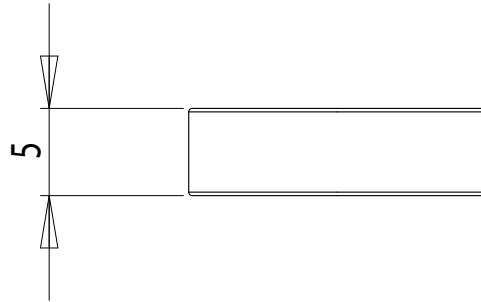
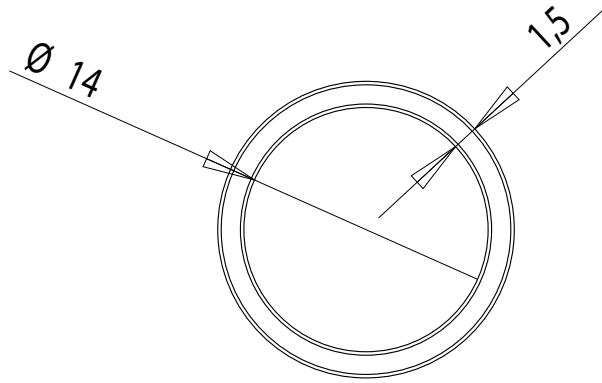

dcw.

Name : LAMP GRAS

Materials : RUBBER

Part : RUBBER

Date :

Rev : 1

Details :

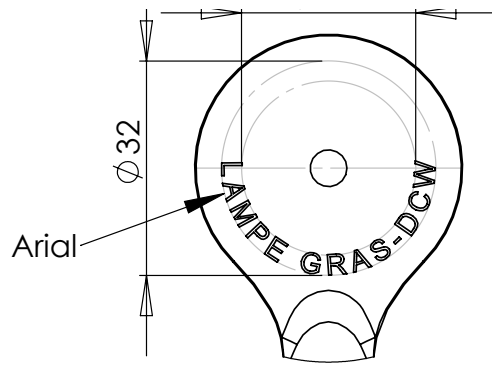
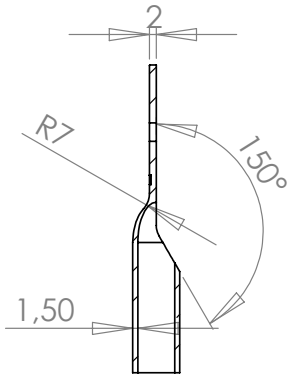

DÉTAIL B

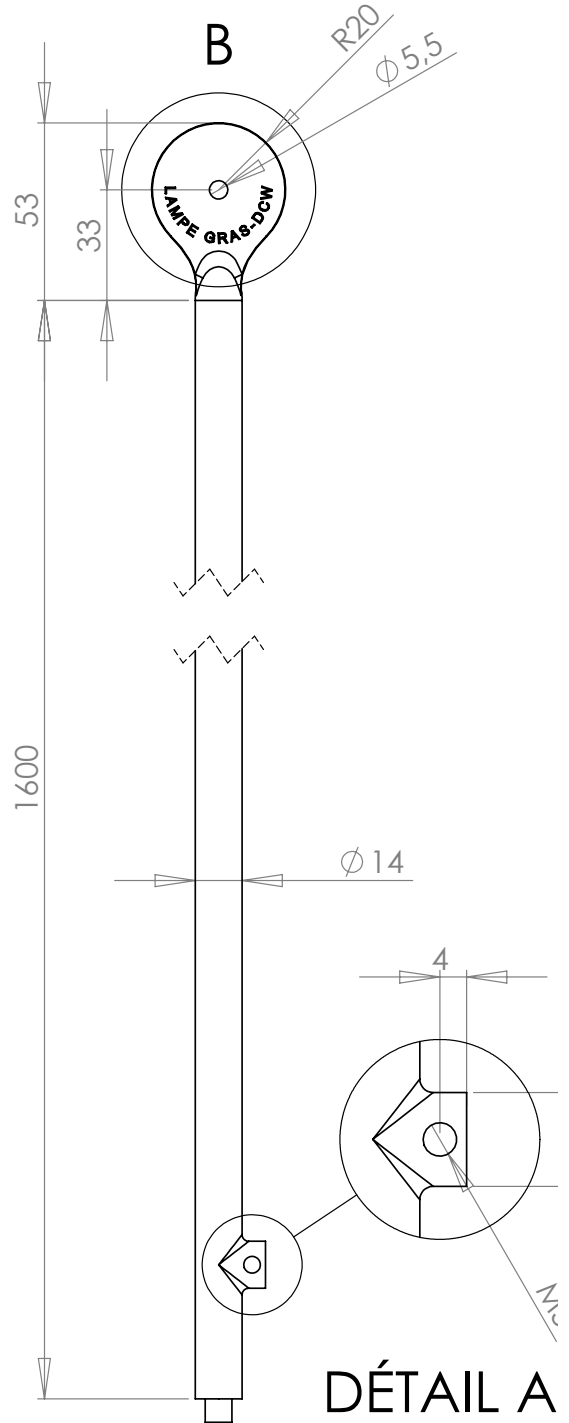
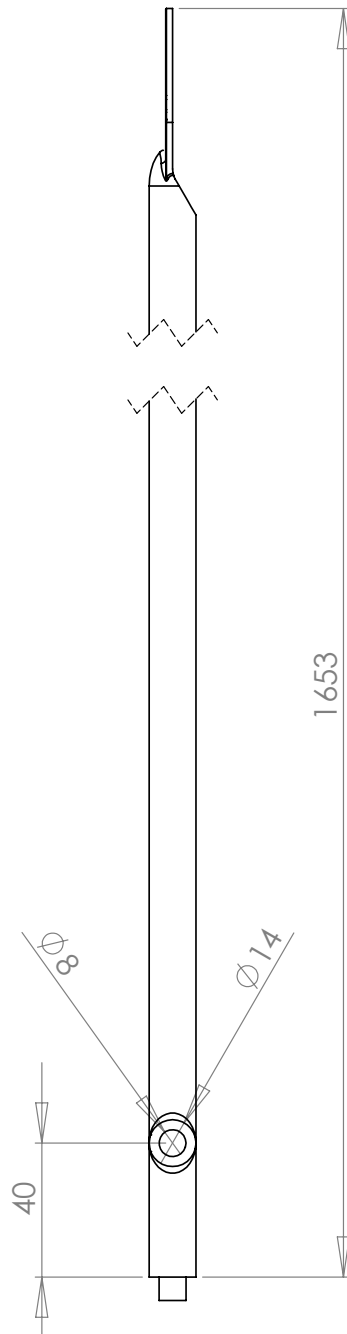
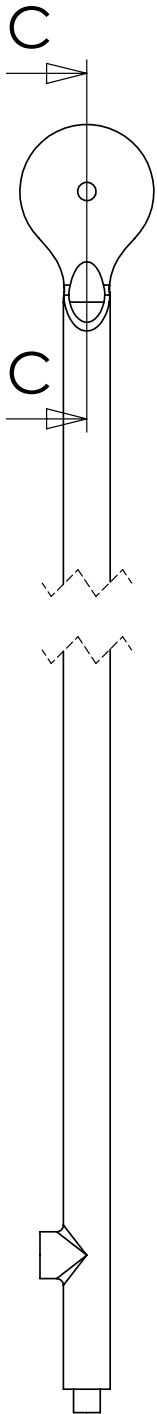

DÉTAIL A  
dcw.

Name : LAMP GRAS

Matériaux : PAINTED STEEL / CHROMED STEEL

Part : TUBE 1 – 1653

Date :

Rev : 1

Details :

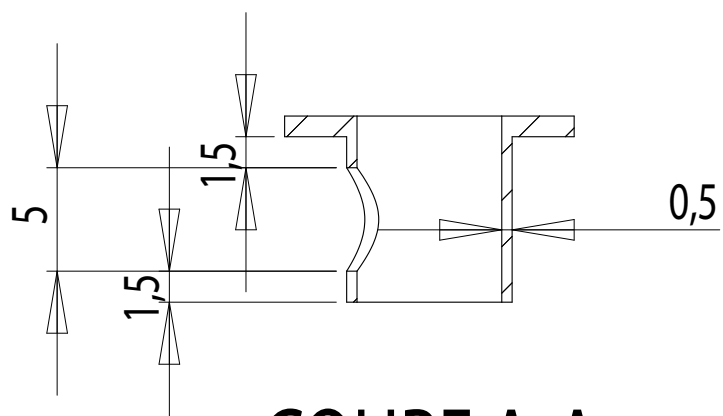
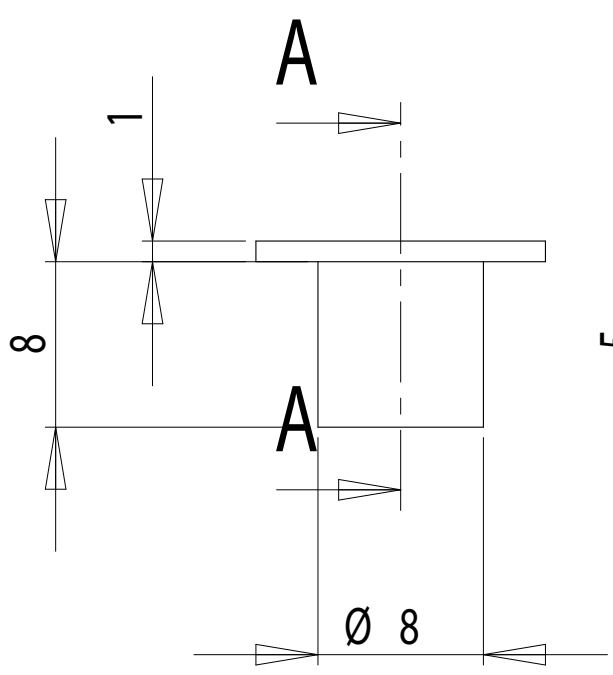
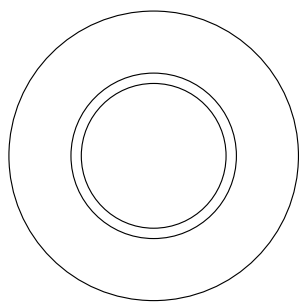

**COUPE A-A**

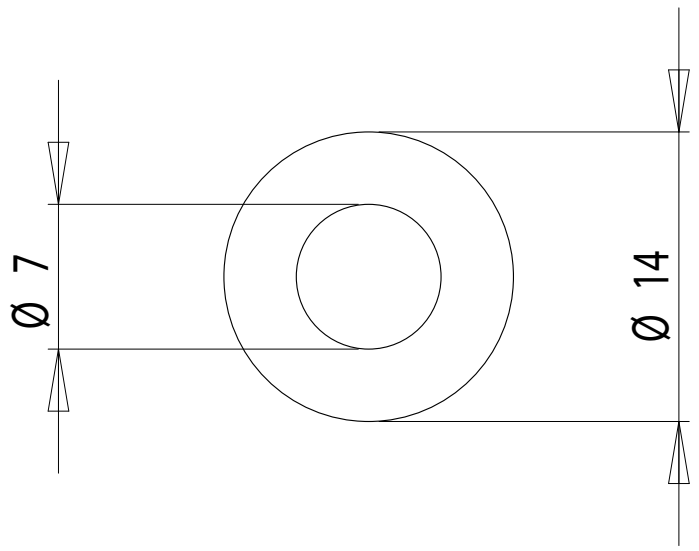

dcw.

Name : **LAMP GRAS**

Materials : BLACK PLASTIC

Part : **CORD GRIPP**

Date :

Rev : 1

Details :

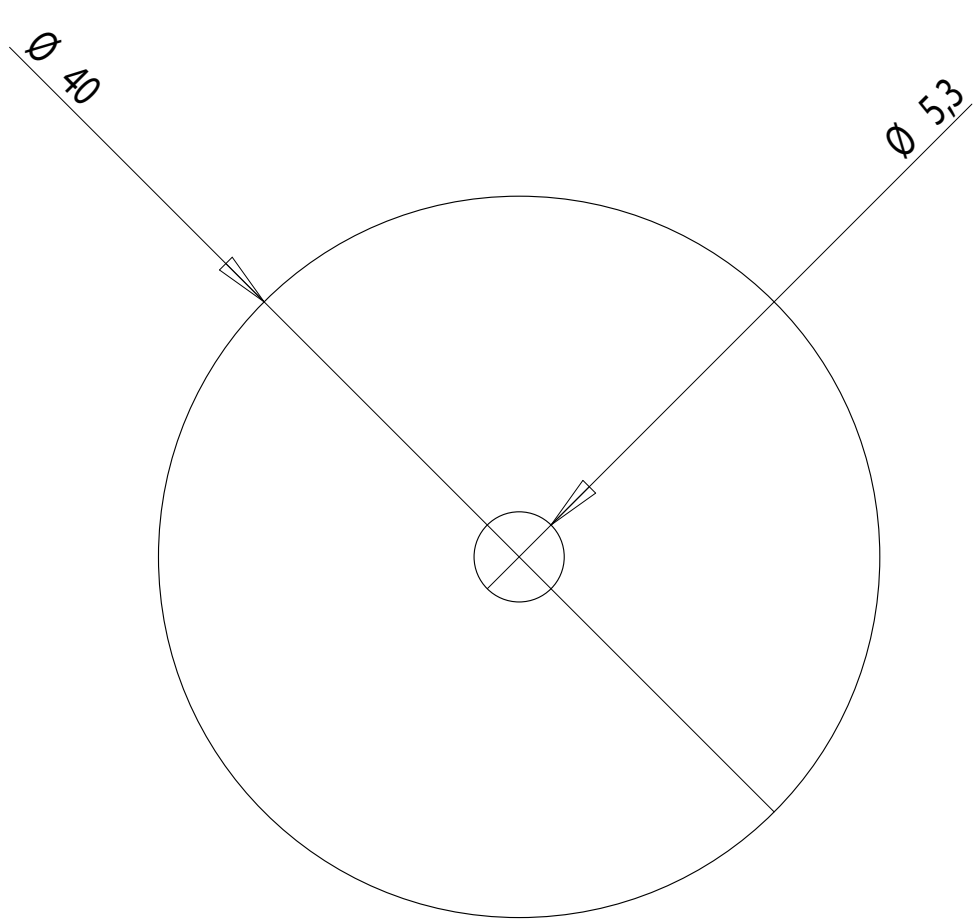

PLIERS SUPPLIED BY DCW

dcw.

Name : LAMP GRAS

Materials : PLASTIC

Part : PLASTIC WASHER – Ø40

Date :

Rev : 1

Details :

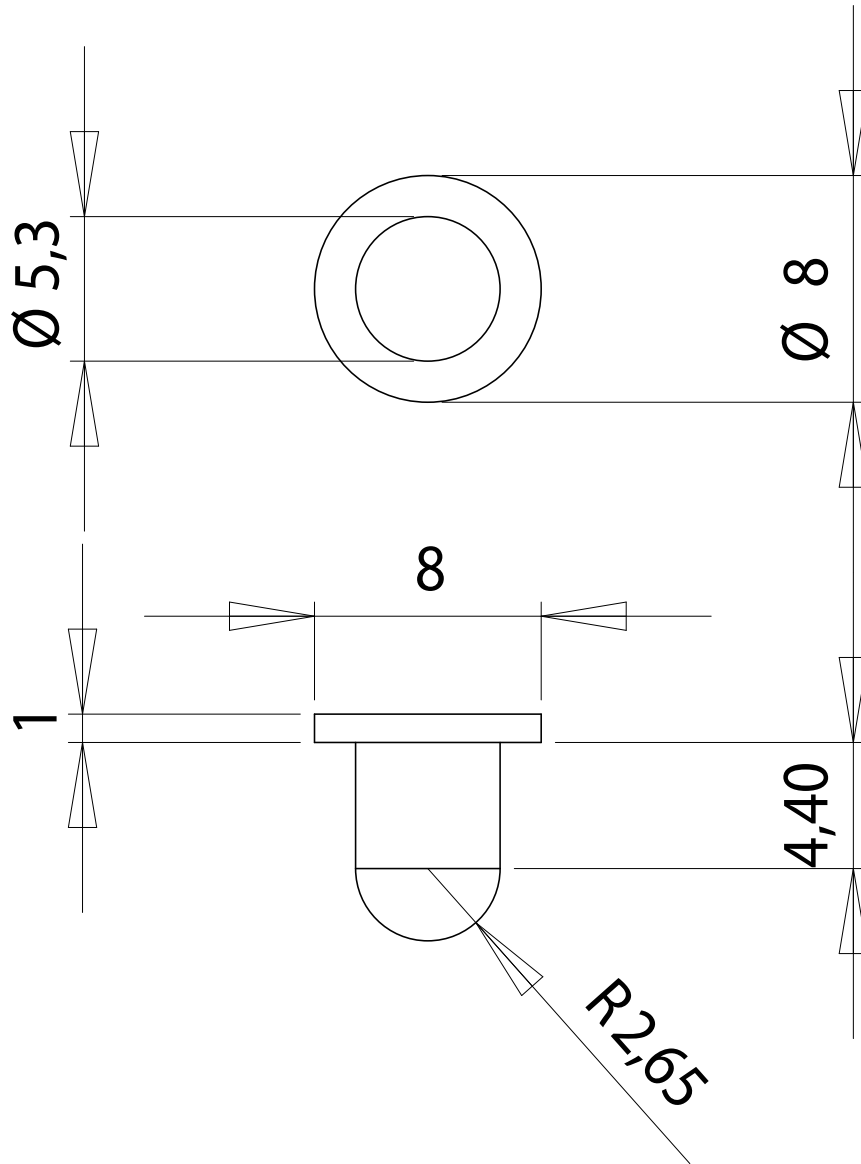

dcw.

Name : LAMP GRAS

Materials : CHROMED STEEL

Part : AXIS

Date :

Rev : 1

Details :

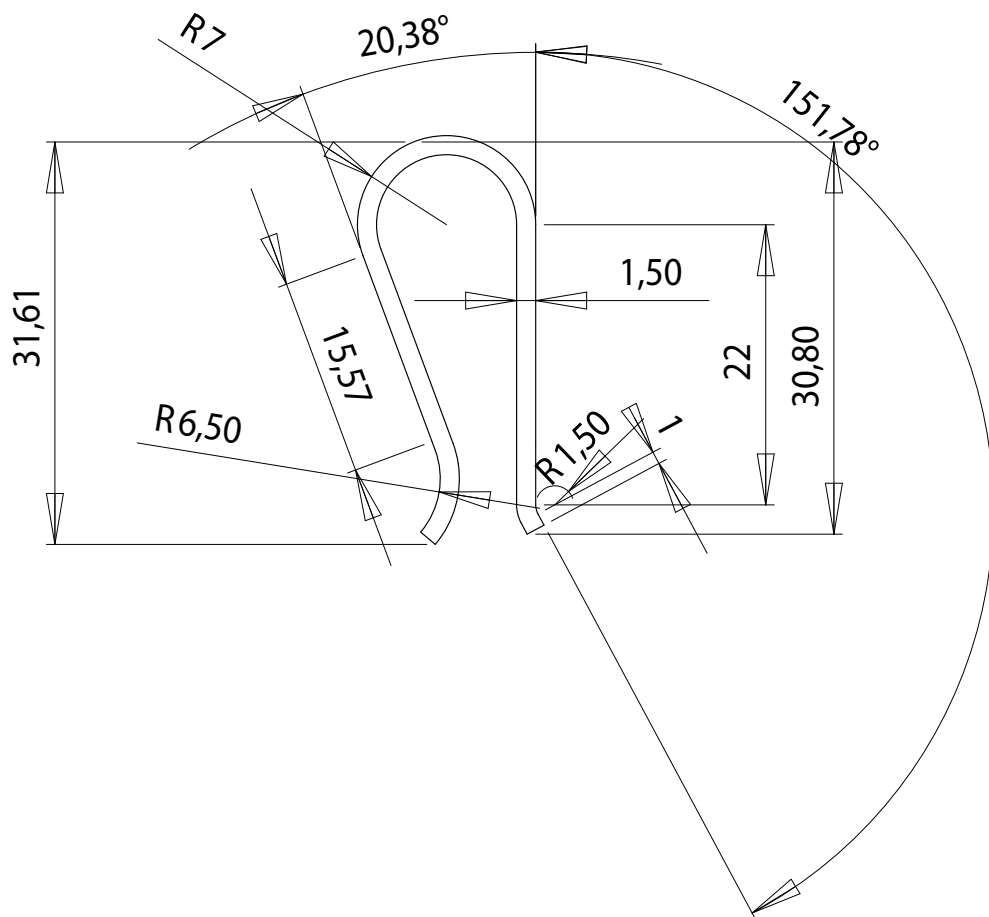
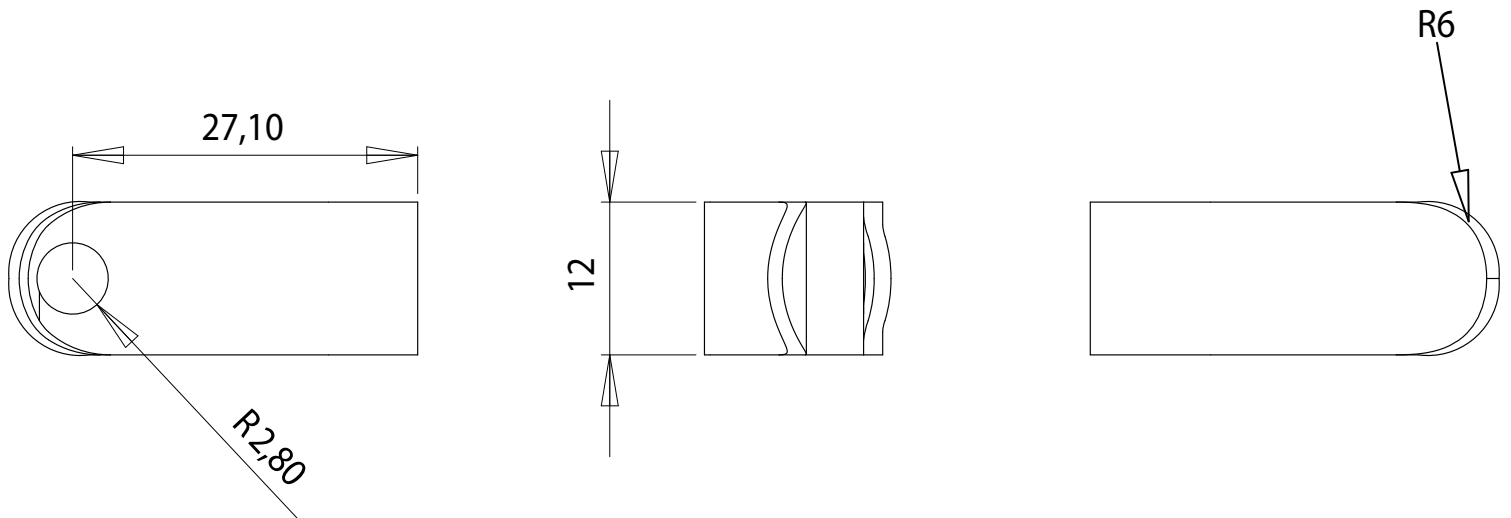

PLIERS SUPPLIED BY DCW

dcw.

Name : LAMP GRAS

Materials : SPRING CHROMED STEEL

Part : PLIERS

Date :

Rev : 1

Details :

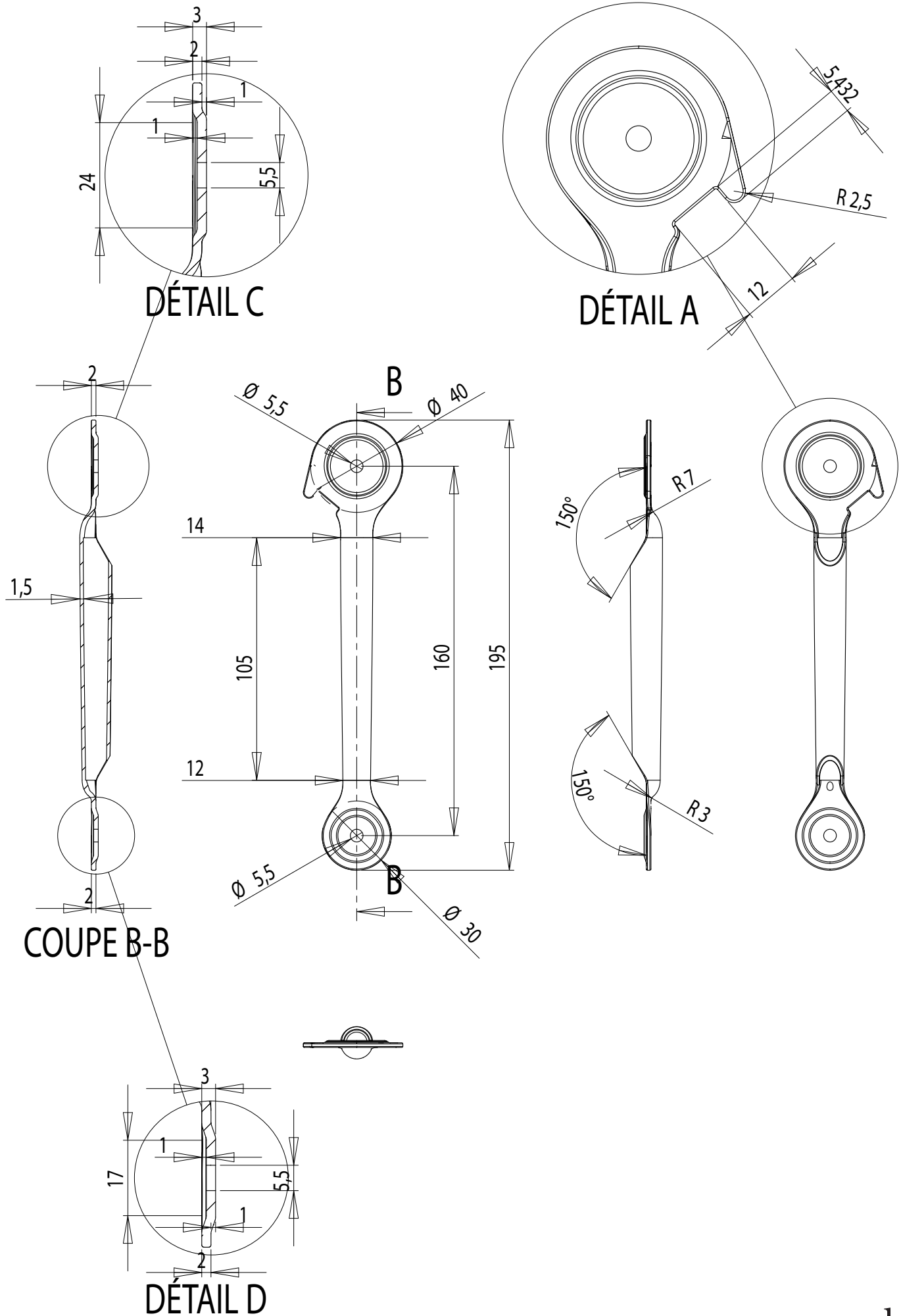

dcw.

Name : <b>LAMP GRAS</b>		Materials : PAINTED STEEL/CHROMED STEEL
Part : <b>TUBE 2</b>		
Date :	Rev : 1	Details :

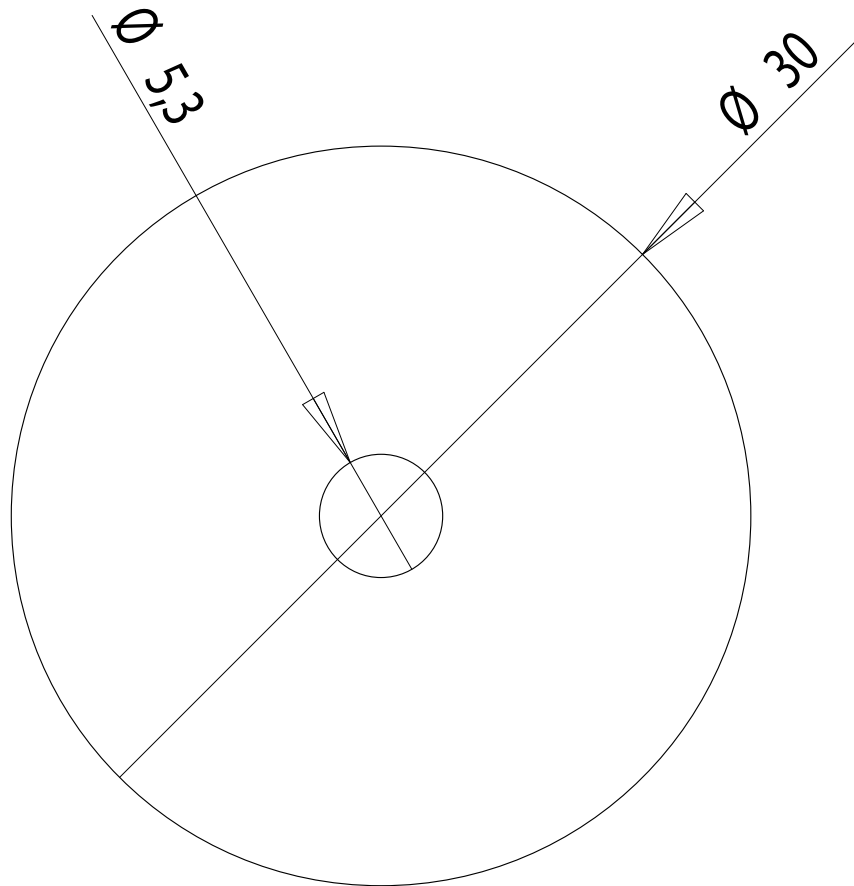

PLIERS SUPPLIED BY DCW

dcw.

Name : LAMP GRAS

Materials : PLASTIC

Part : PLASTIC WASHER – Ø30

Date :

Rev : 1

Details :

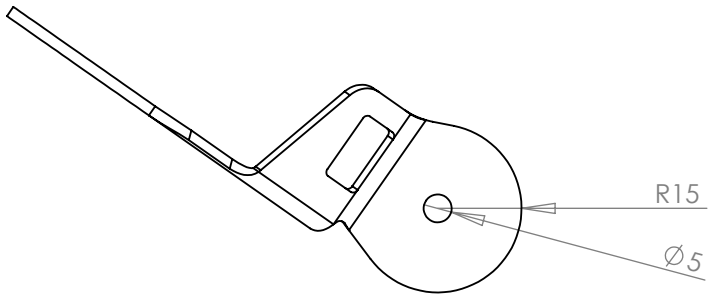
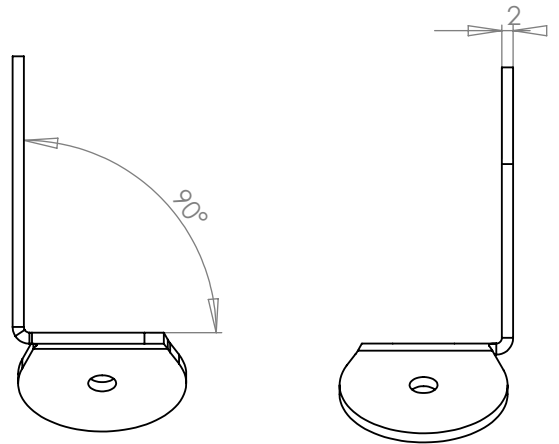
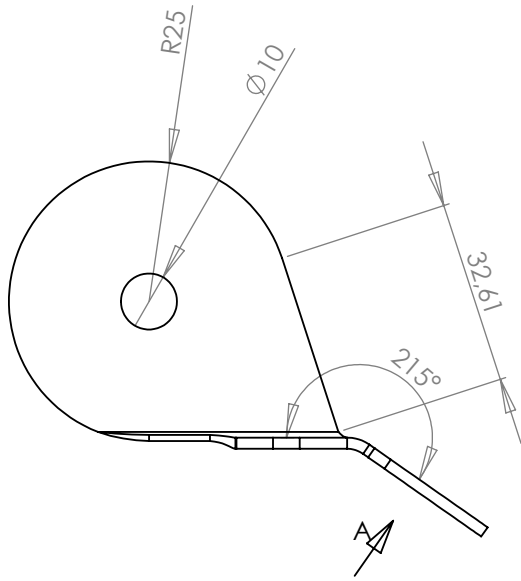
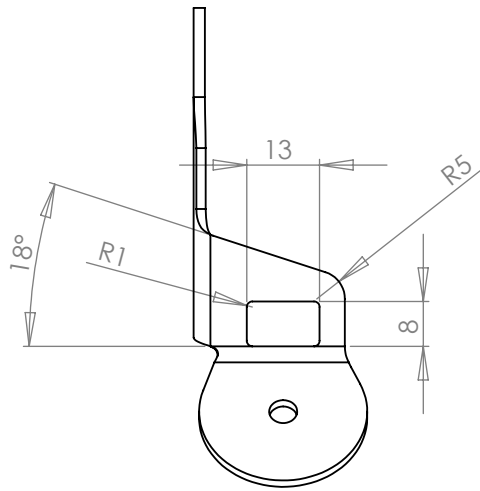

VUE A

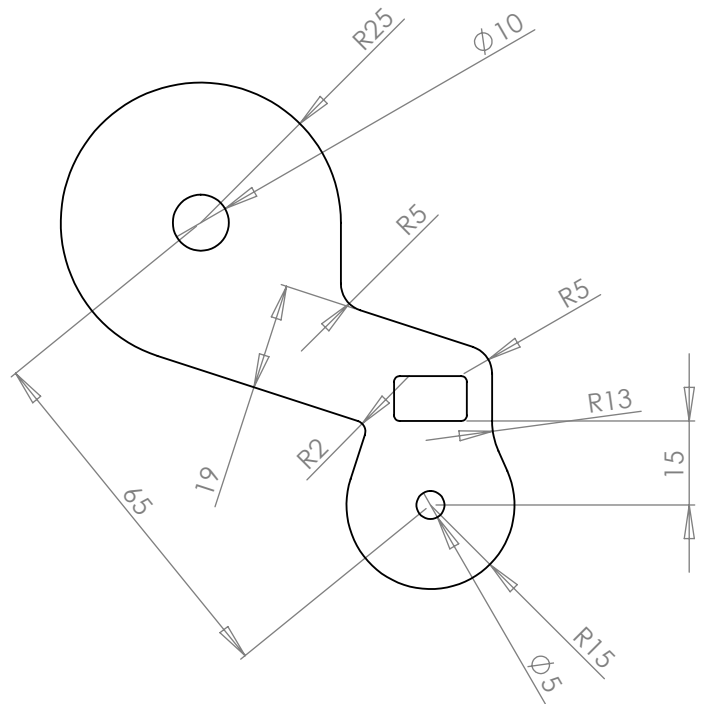

dcw.

Name : **LAMP GRAS**

Materials : PAINTED STEEL / CHROMED STEEL

Part : **JUNCTION PIECE for E27**

Date :

Rev : 1

Details :

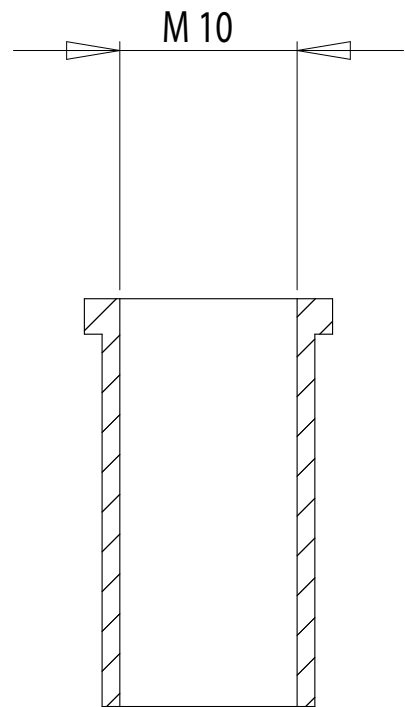
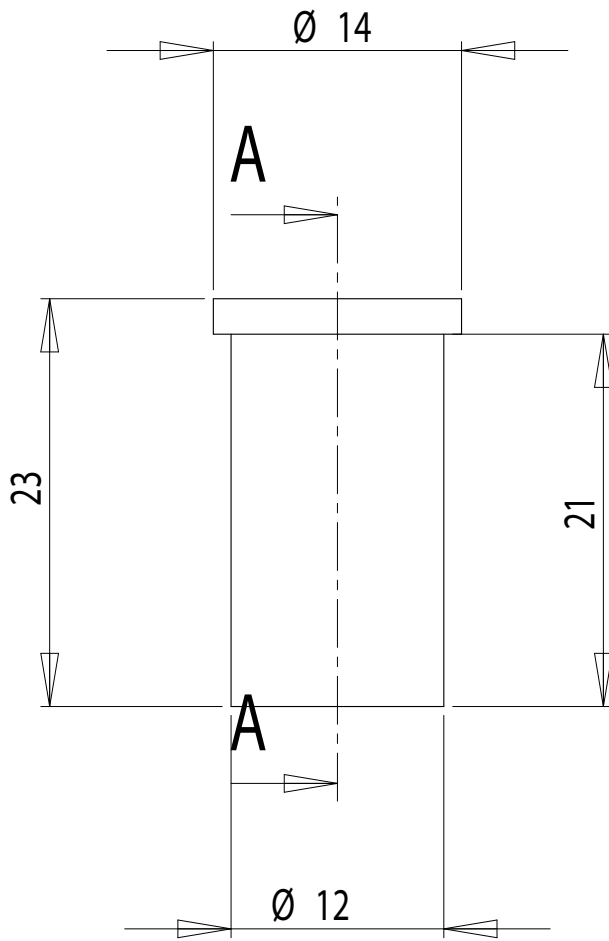

COUPE A-A

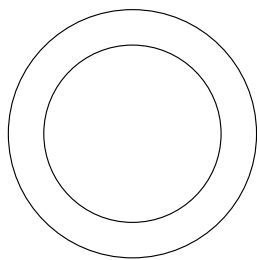

dcw.

Name : **LAMP GRAS**

Part : **FIXATION PIECE**

Date :

Rev : 1

Materials : PAINTED STEEL / CHROMED STEEL

Details :

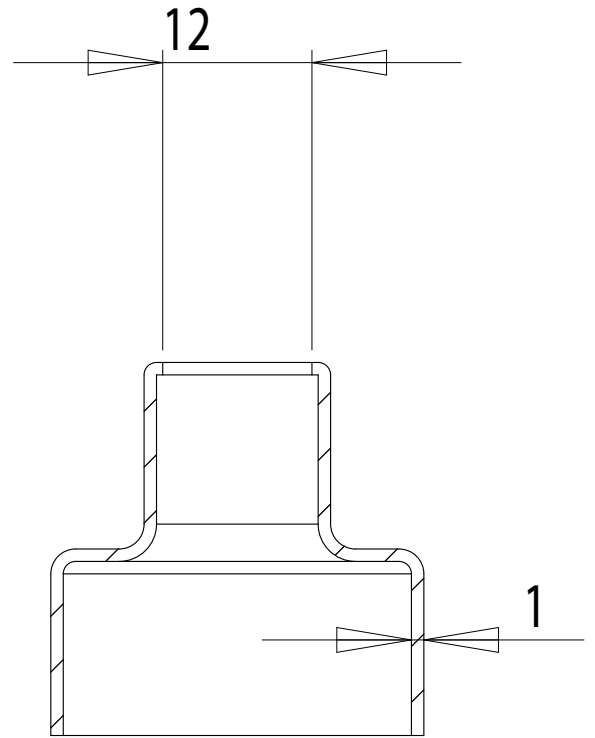
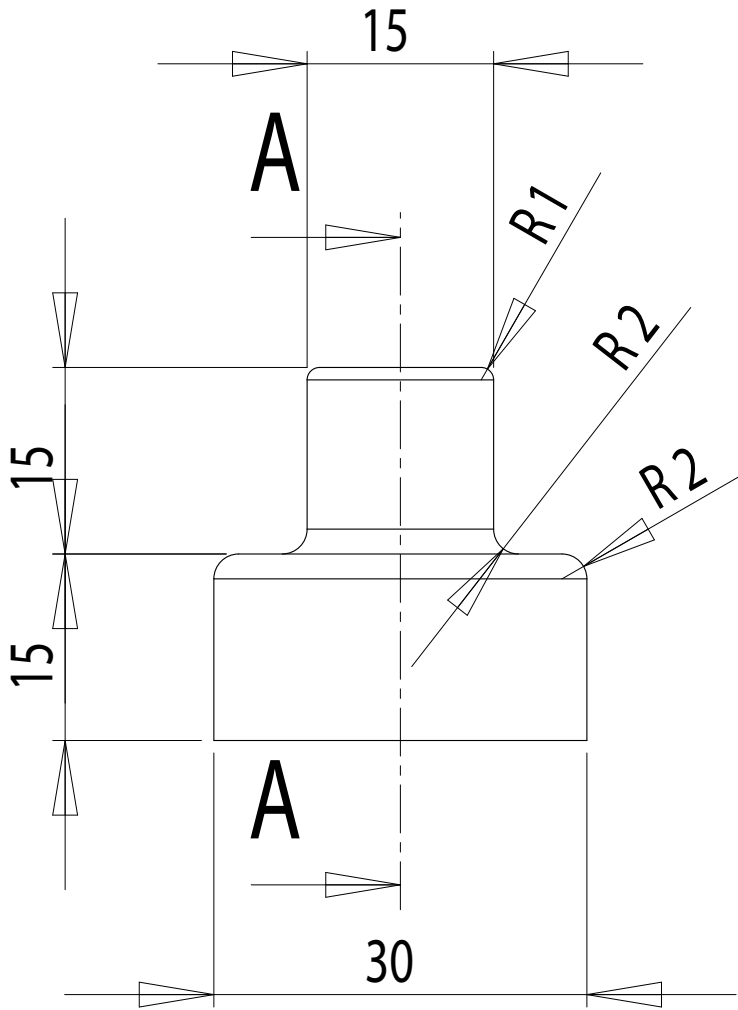

**COUPE A-A**

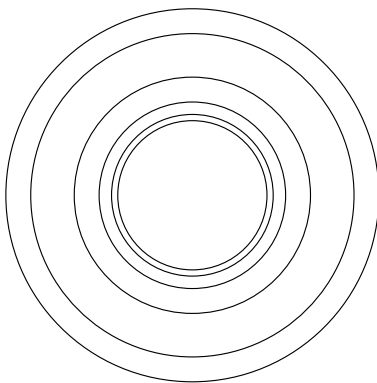

dcw.

Name : **LAMP GRAS**

Materials : PAINTED STEEL / CHROMED STEEL

Part : **COVERING PIECE**

Date :

Rev : 1

Details :

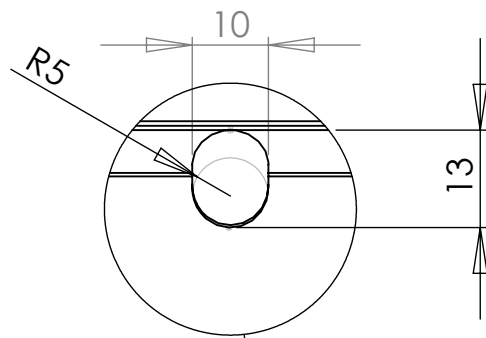
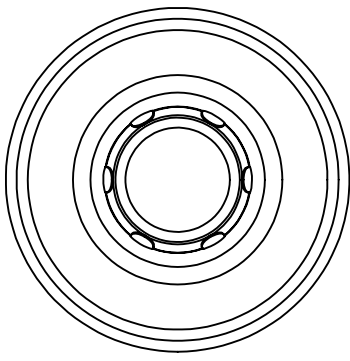

DÉTAIL C

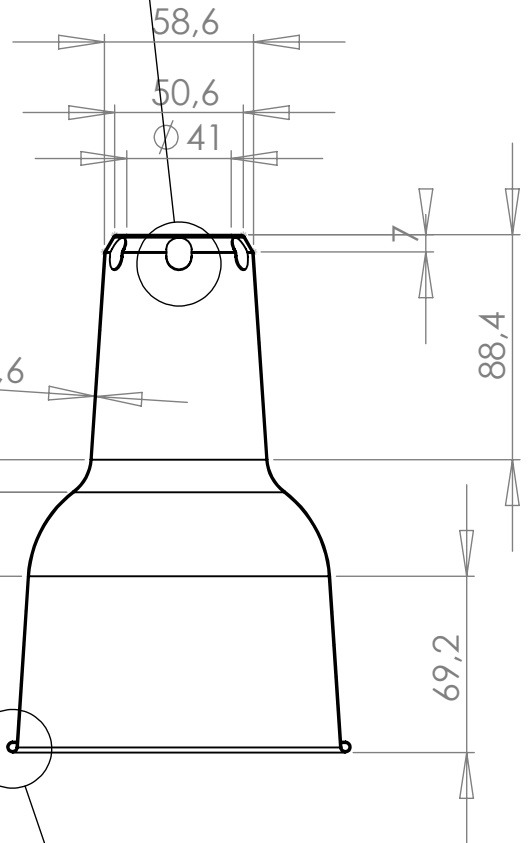
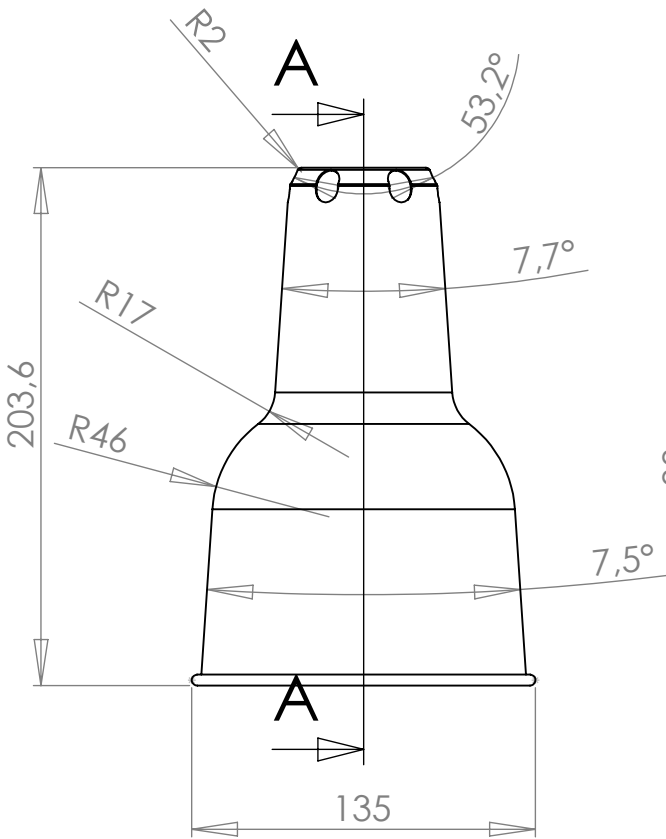

COUPE A-A

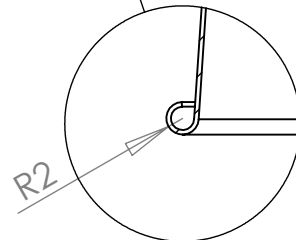
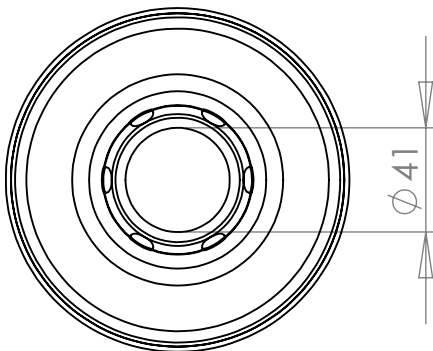

DÉTAIL B

dcw.

Name : LAMP GRAS

Matériaux : PAINTED STEEL

Part : CYLINDER SHADE

Date :

Rev : 1

Details :

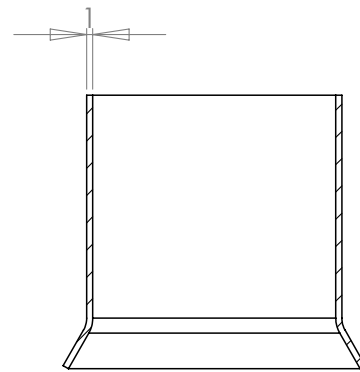
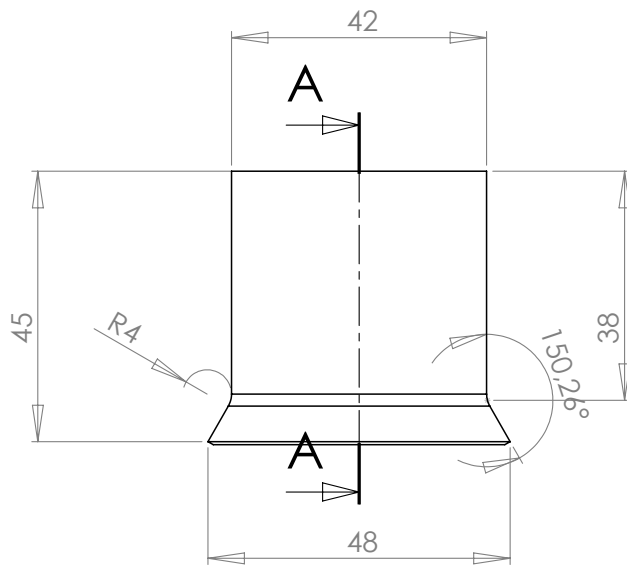
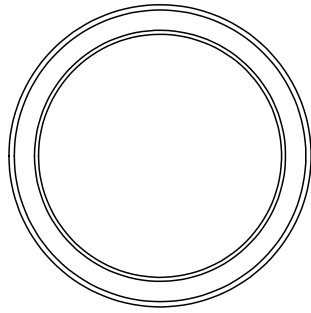

COUPE A-A

