



| Qty | Piece | Finishing | | | |
|-----|--------------------|-------------|---|----------------------|------------------------------|
| 1 | WALL PIECE | BLACK SATIN | 1 | JUNCTION PIECE | BLACK SATIN |
| 1 | WALL PIECE 2 | BLACK SATIN | 1 | COVERING PIECE | BLACK SATIN |
| 1 | CAST SPRING | | 1 | FIXATION PIECE | BLACK SATIN |
| 1 | SPHERE | BLACK | 1 | ROUND SHADE | BLACK OUTSIDE / WHITE INSIDE |
| 1 | BALL BREAKER | | 1 | BULBHOLDER SPACER | CHROME |
| 1 | RUBBER | BLACK | 1 | BULBHOLDER SCREW | CHROME |
| 1 | CORD GRIPP | BLACK | 1 | BULBHOLDER | |
| 1 | TUBE 1 | BLACK SATIN | 3 | M10 x 4 NUT | |
| 1 | TUBE 2 | BLACK SATIN | 2 | M5 x 5 PLASTIC SCREW | BLACK |
| 1 | BREAKING HANDLE | BLACK SATIN | 1 | THREAD 10X100 | |
| 1 | PLASTIC WASHER Ø40 | RED | | | |
| 1 | PLASTIC WAHSER Ø30 | RED | | | |
| 1 | PLIERS | CHROME | | | |
| 1 | AXIS | CHROME | | | |

dcw.

Name : LAMP GRAS N°304 L40 BL-SAT

Matérials :

Part :

Date : 06/02/2013

Rev : 1

Details : E14 - 11w ; Arditi métal bulbholder ; Switch on cast
Black fabric wire

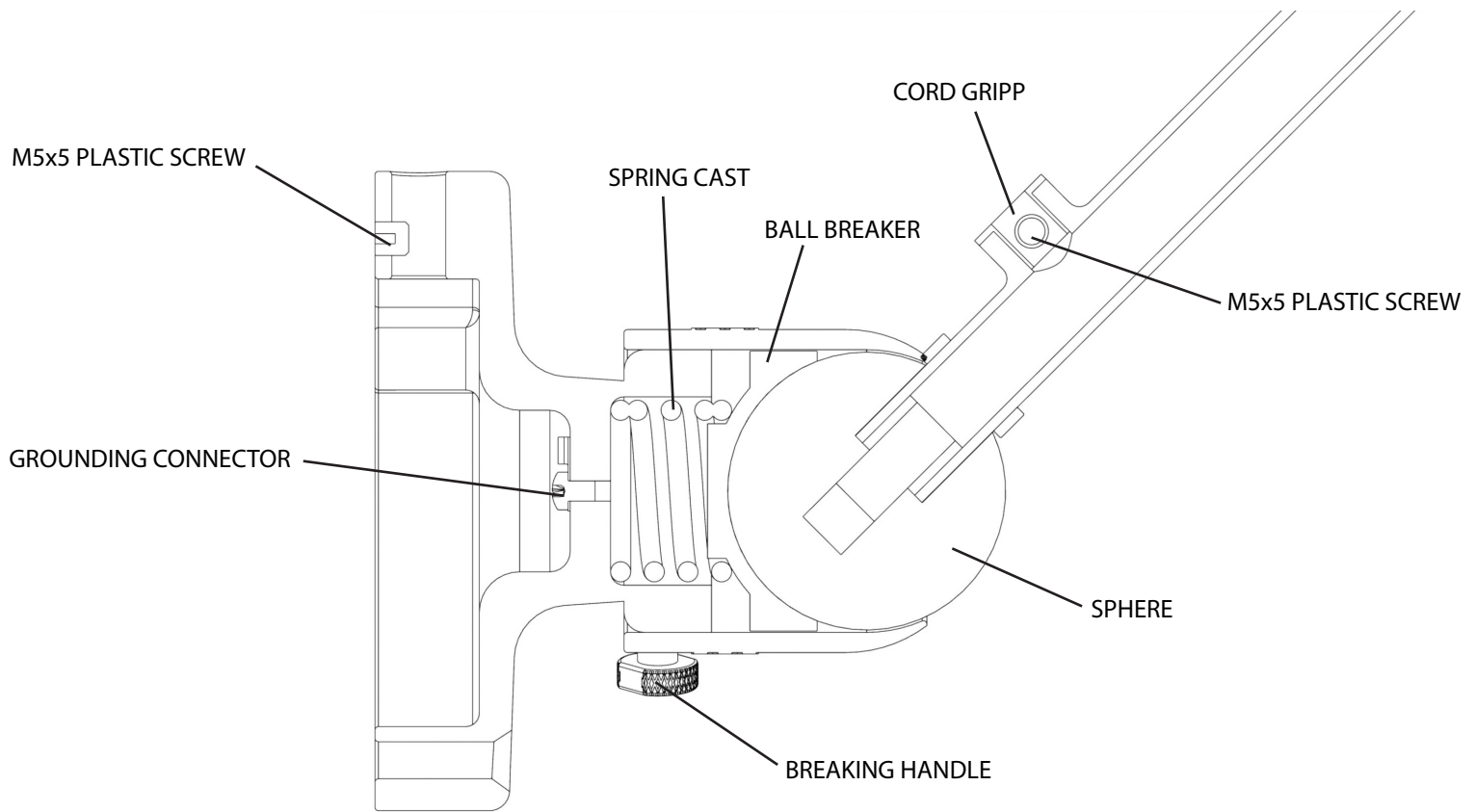
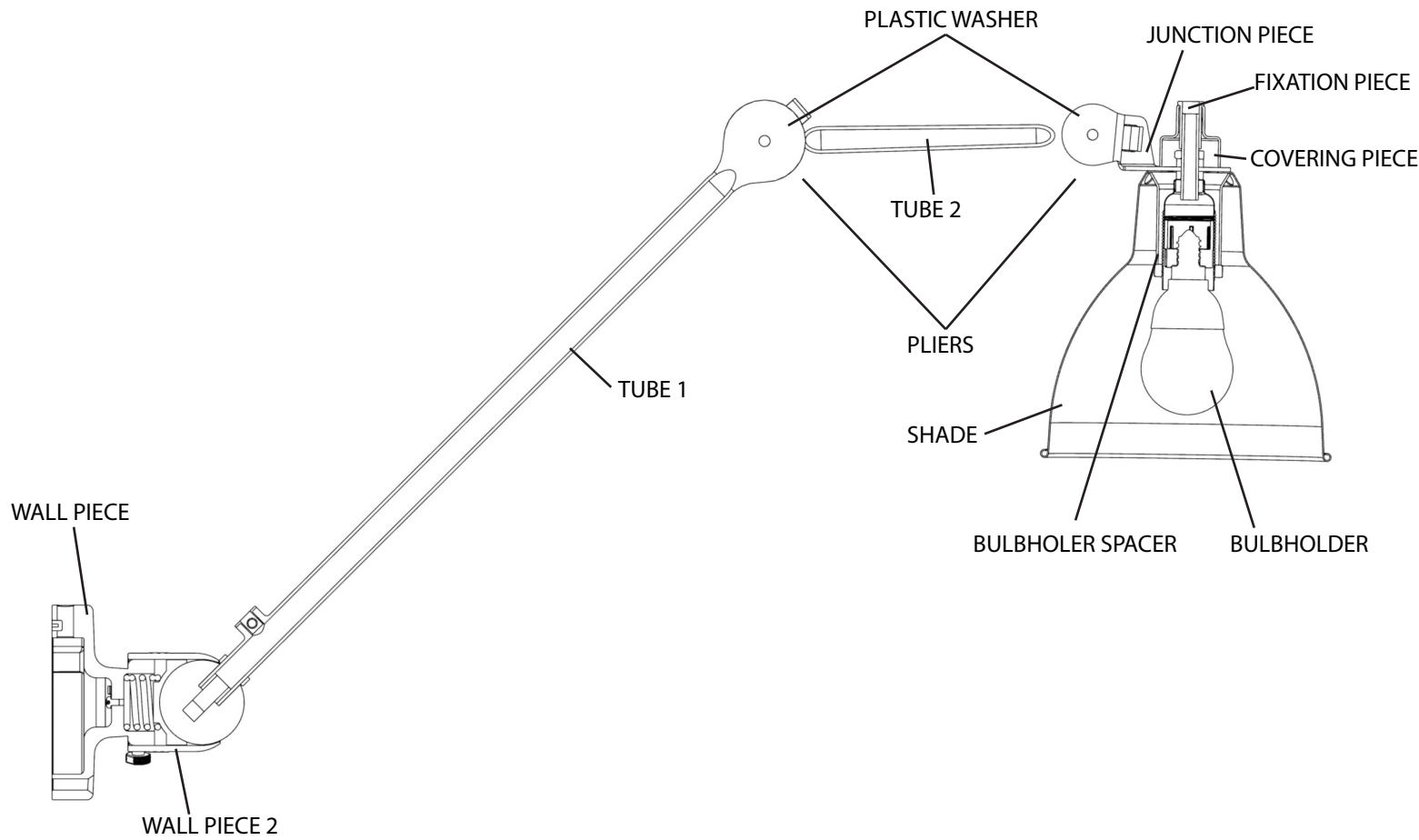

dcw.

Name : LAMP GRAS N°304 L

Part : ELEMENTS

Date :

Rev : 1

Matériaux :

Details : E14 - 11w ; Arditì métal bulbholder ; Switch on cast
Black fabric wire

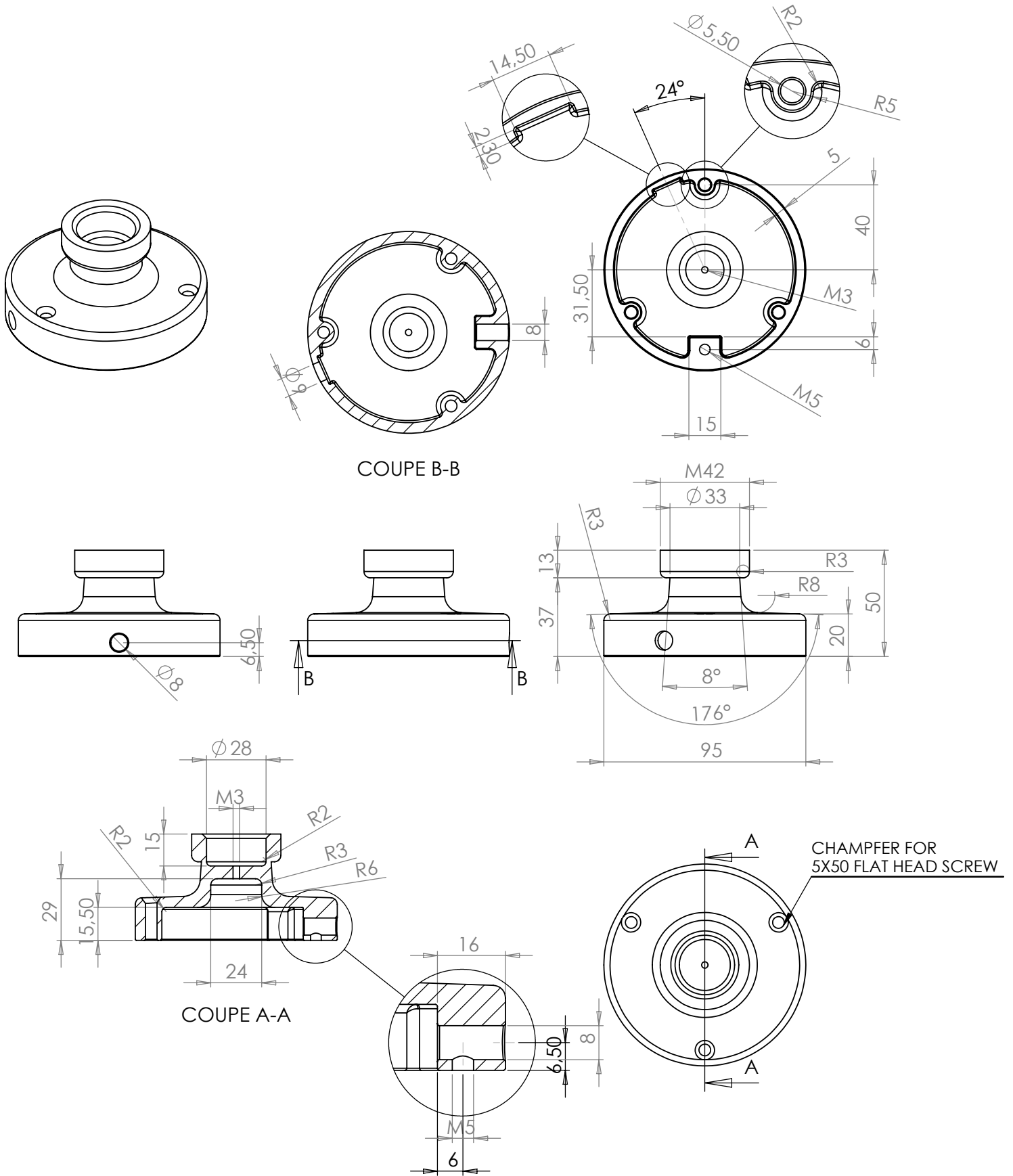

dcw.

Name : LAMP GRAS N°302/304

Materials : PAINTED STEEL

Part : WALL PIECE

Date :

Rev : 1

Details :

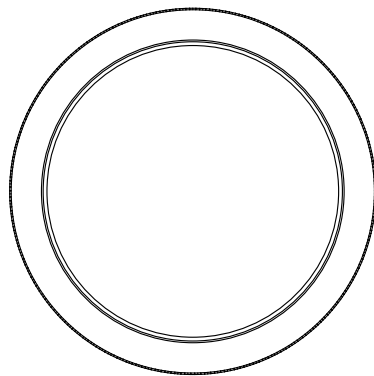
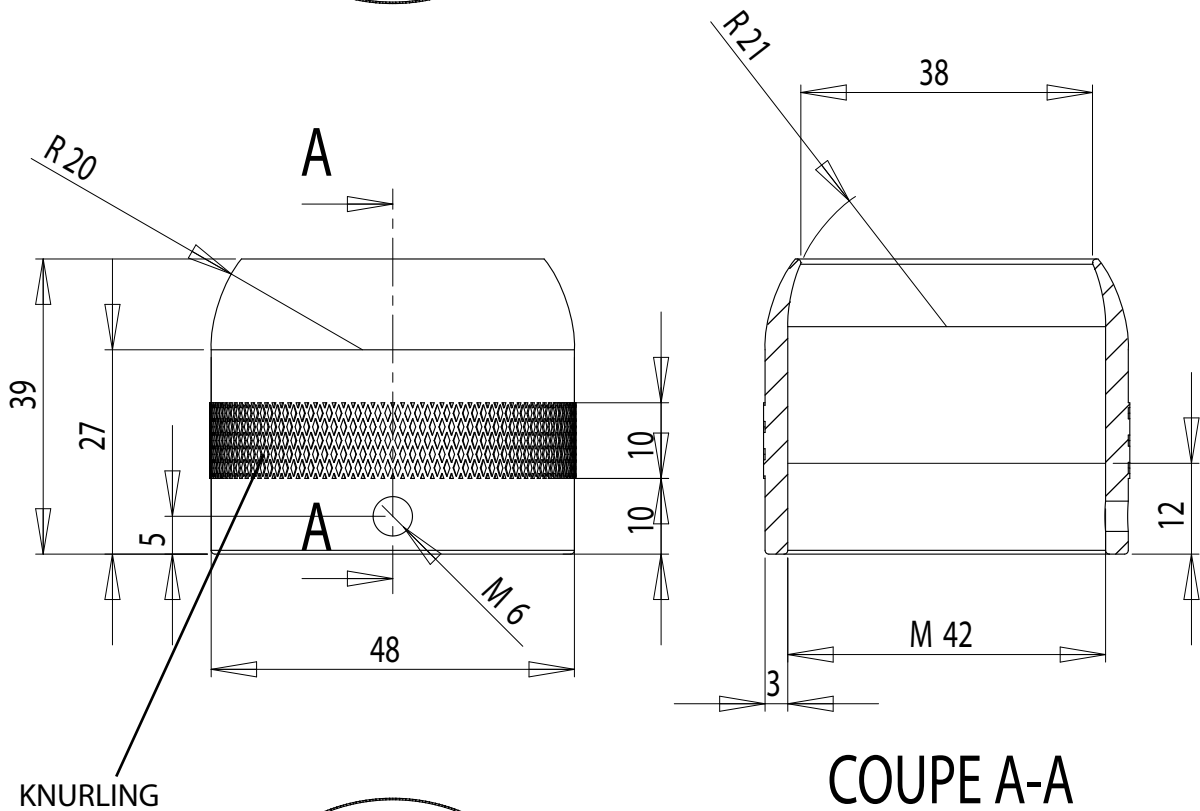
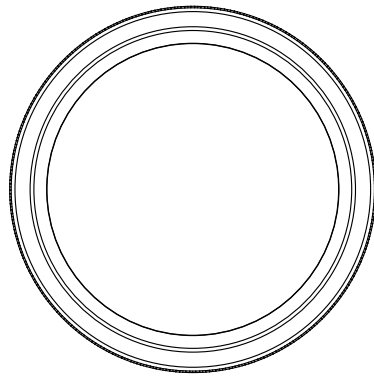

dcw.

Name : LAMP GRAS N°302/304

Materials : PAINTED STEEL

Part : WALL PIECE 2

Date :

Rev : 1

Details :

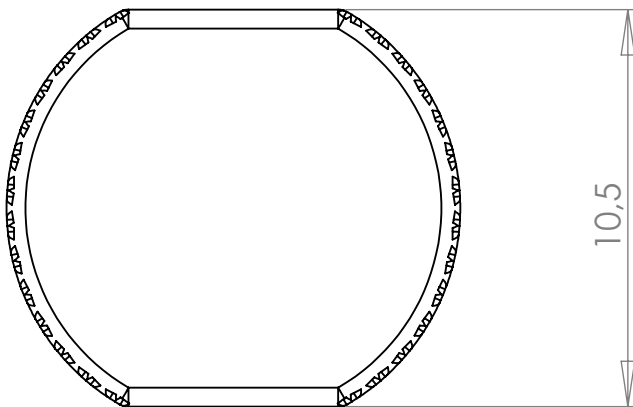
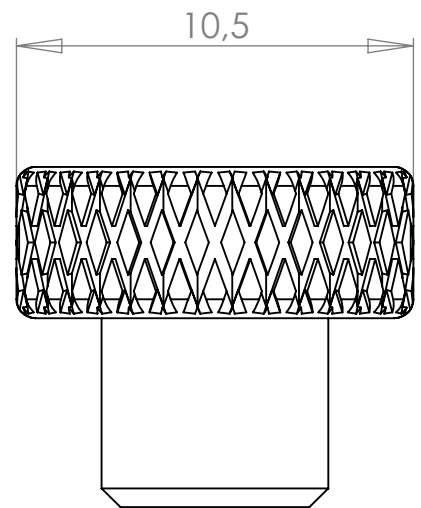
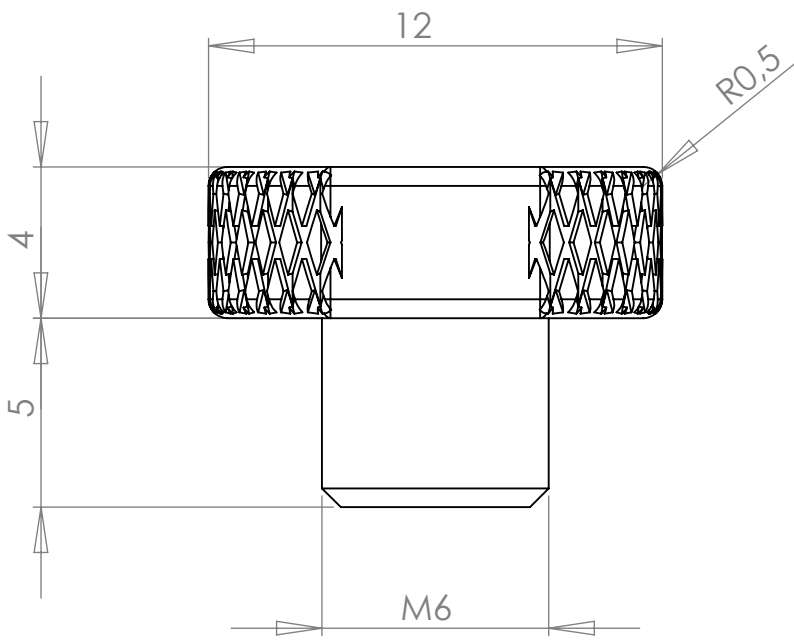
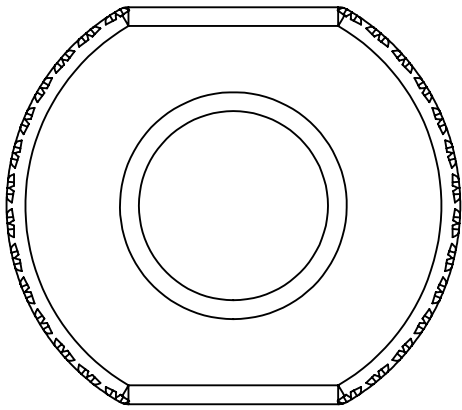

dcw.

Name : LAMP GRAS N°302/304

Materials : PAINTED STEEL

Part : BREAKING HANDLE

Date :

Rev : 2

Details :

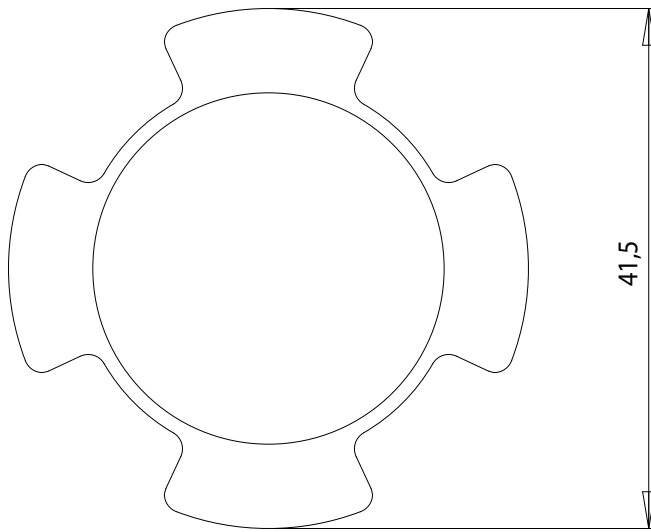

41,5

A

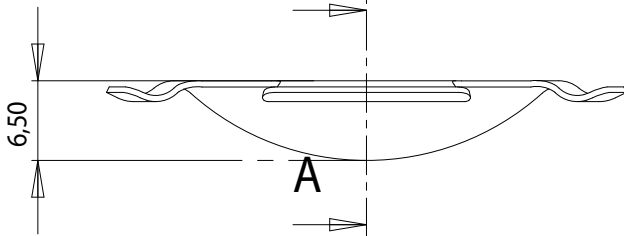

A

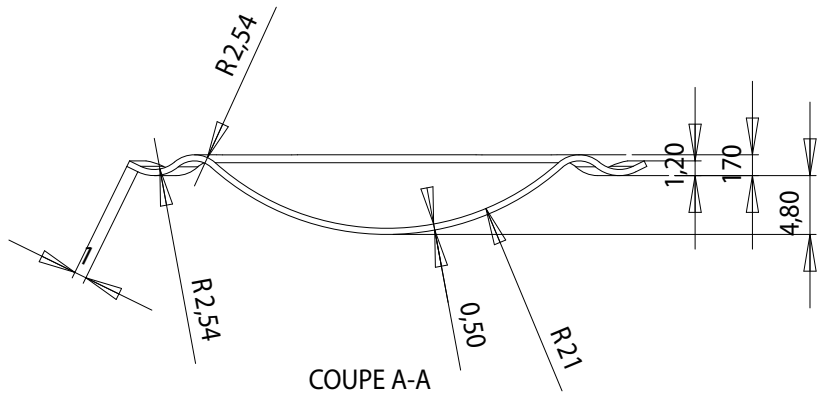

COUPE A-A

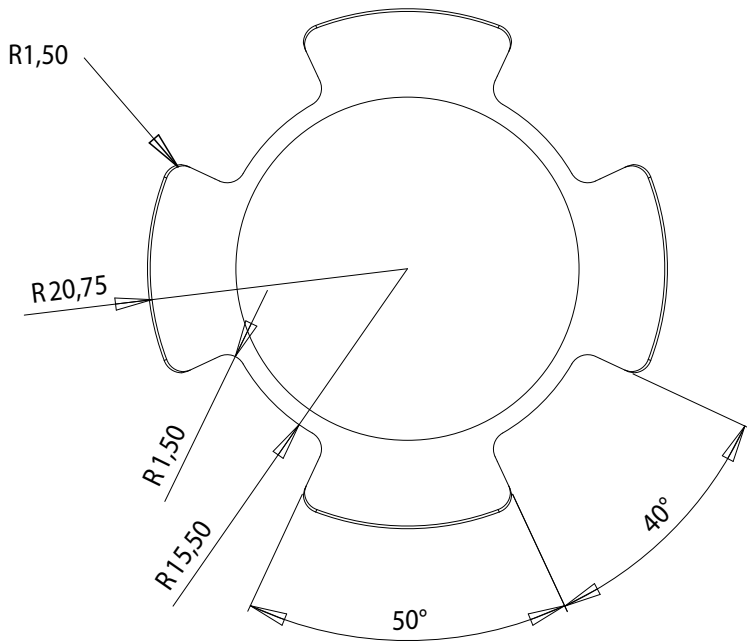

R1,50

R20,75

R1,50

R15,50

50°

40°

dcw.

Name : **LAMP GRAS**

Materials : SPRING STEEL

Part : **SPRING**

Date :

Rev : 1

Details :

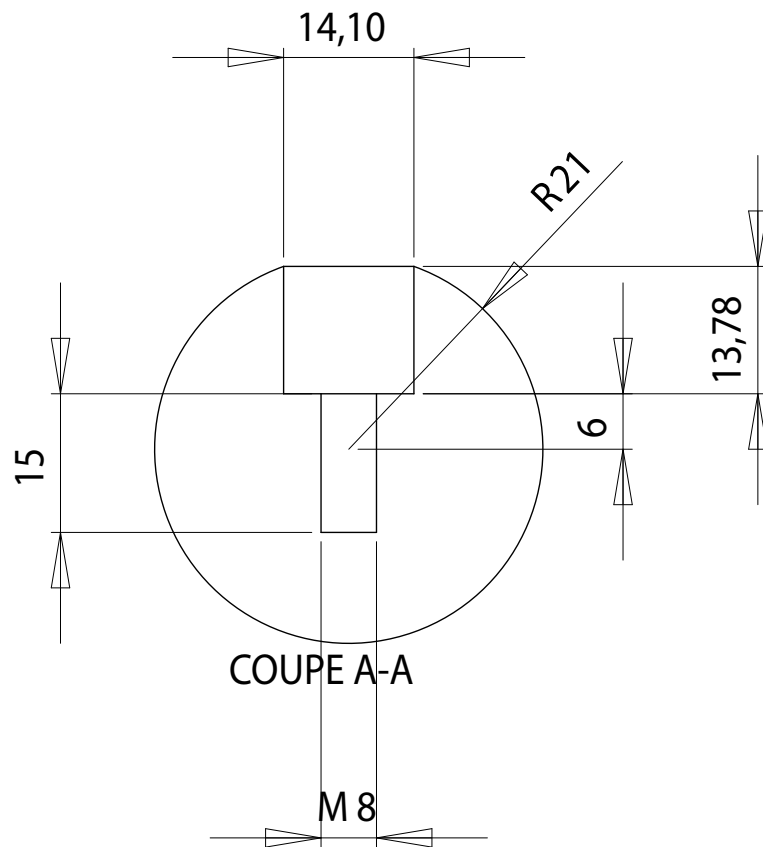
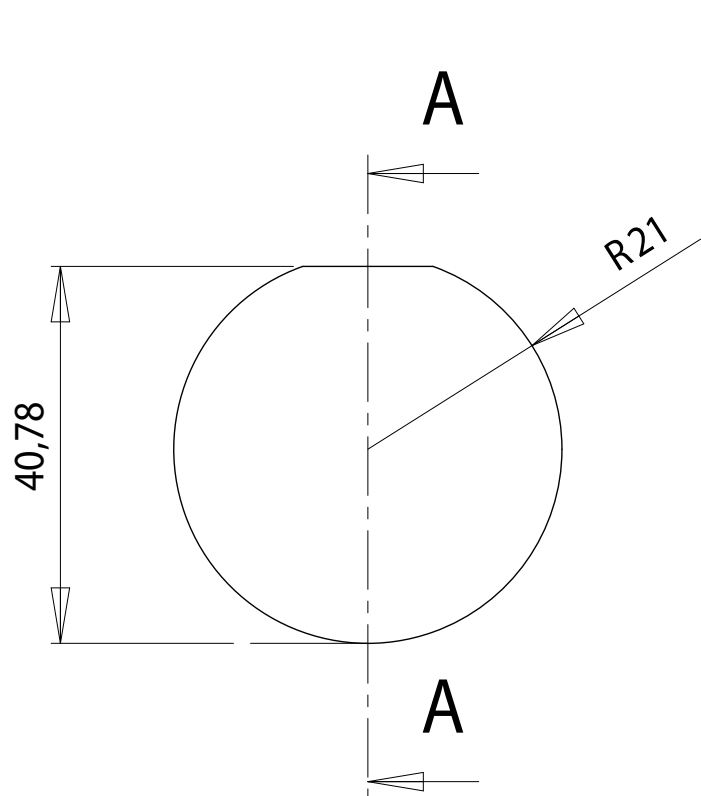

dcw.

Name : LAMP GRAS

Matériaux : BLACK BAKELITE

Part : SPHERE

Date :

Rev : 1

Details :

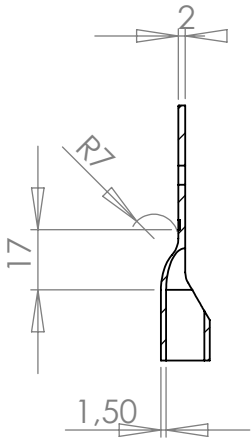

COUPE C-C

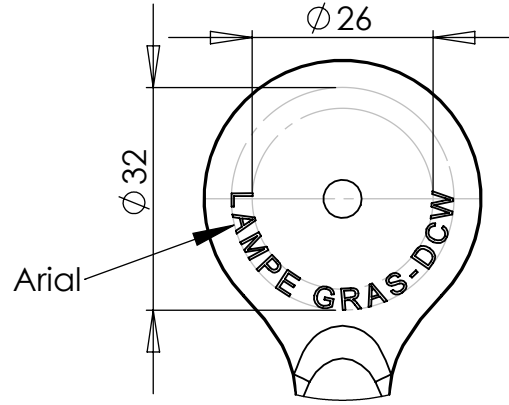

DÉTAIL B

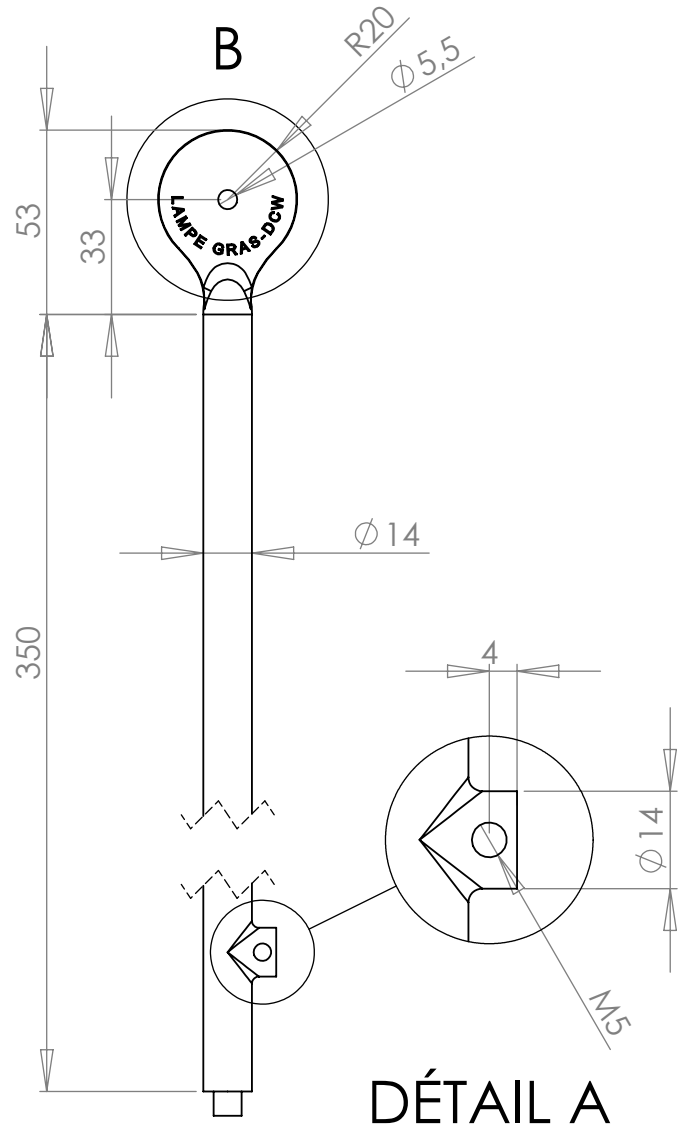
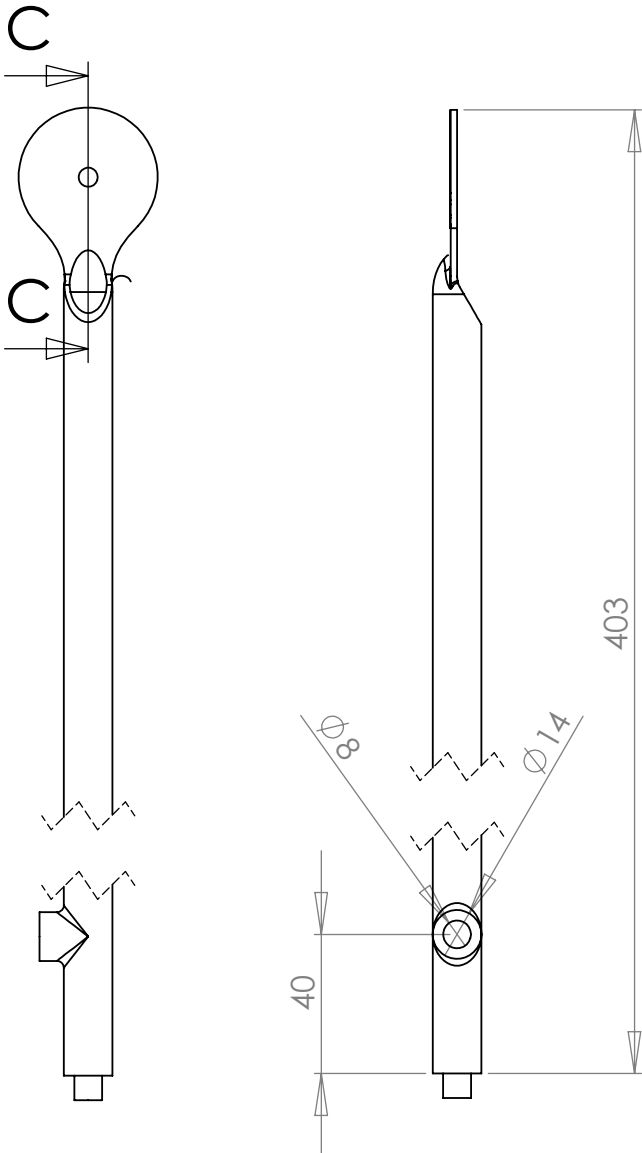

DÉTAIL A

dcw.

Name : LAMP GRAS

Matériaux : PAINTED STEEL / CHROMED STEEL

Part : TUBE 1 – 403

Date :

Rev : 1

Details :

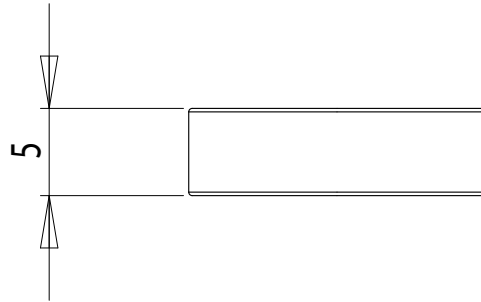
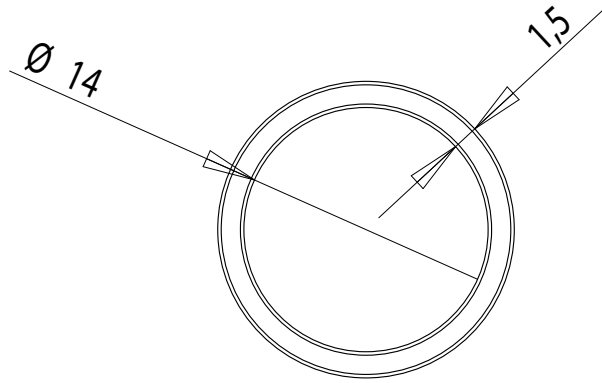

dcw.

Name : LAMP GRAS

Materials : RUBBER

Part : RUBBER

Date :

Rev : 1

Details :

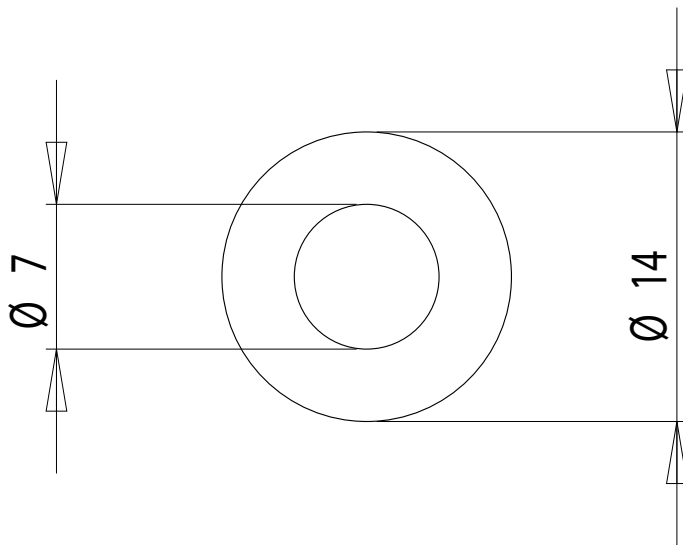
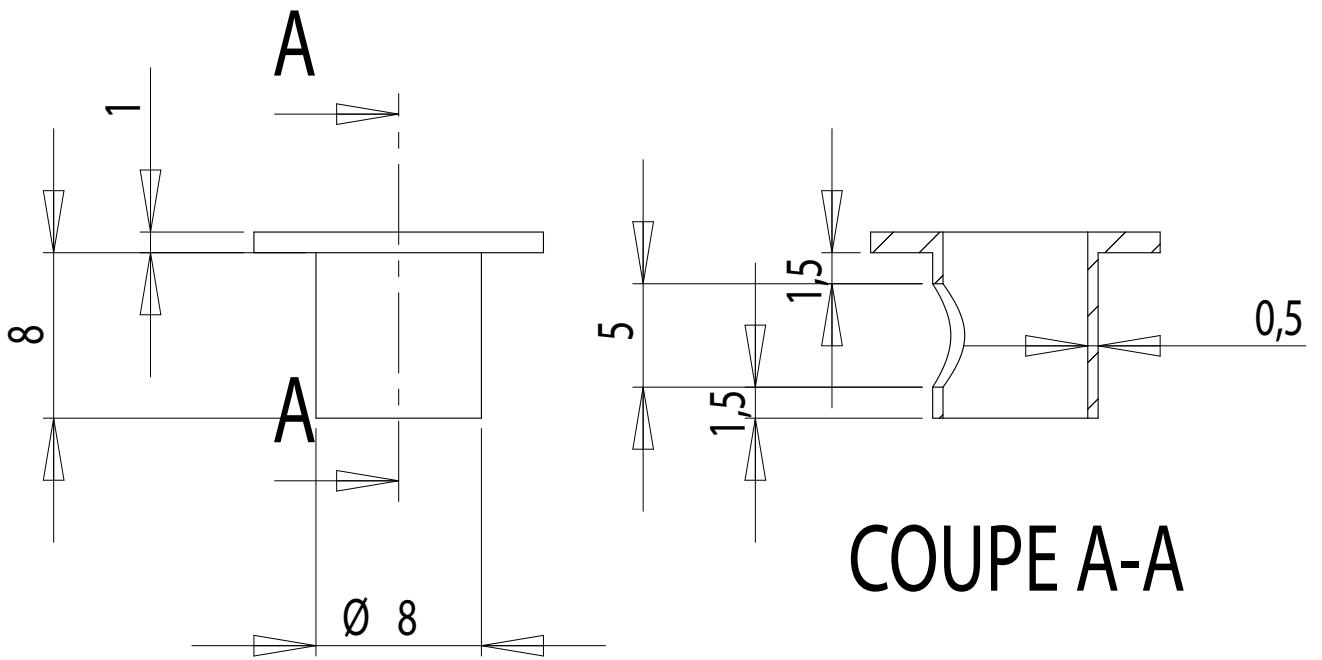
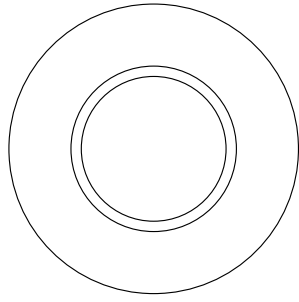

dcw.

Name : **LAMP GRAS**

Matériaux : BLACK PLASTIC

Part : **CORD GRIPP**

Date :

Rev : 1

Details :

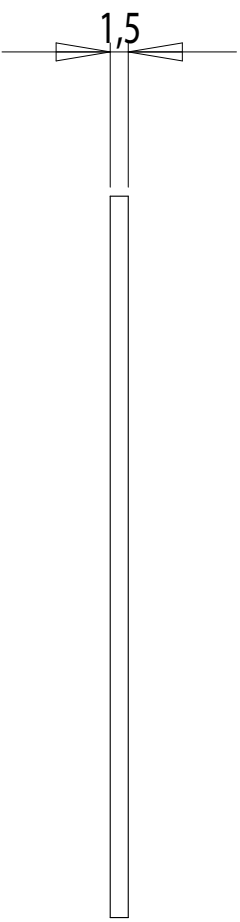
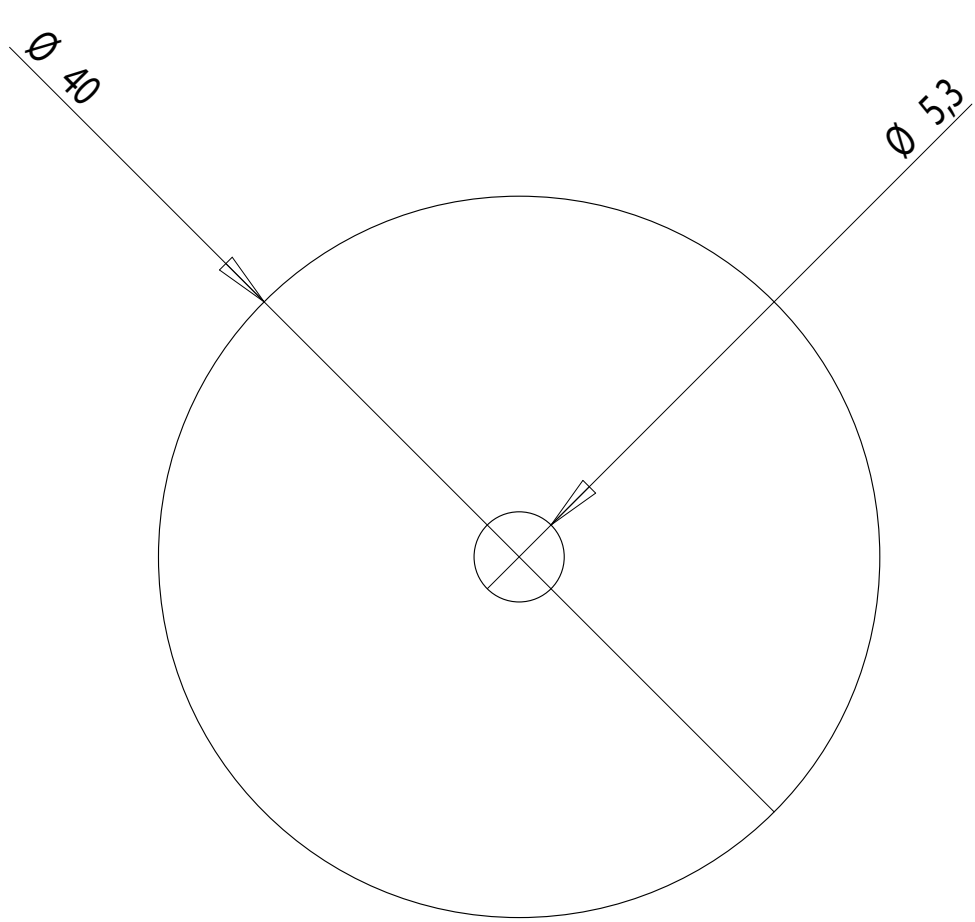

PLIERS SUPPLIED BY DCW

dcw.

Name : LAMP GRAS

Materials : PLASTIC

Part : PLASTIC WASHER – Ø40

Date :

Rev : 1

Details :

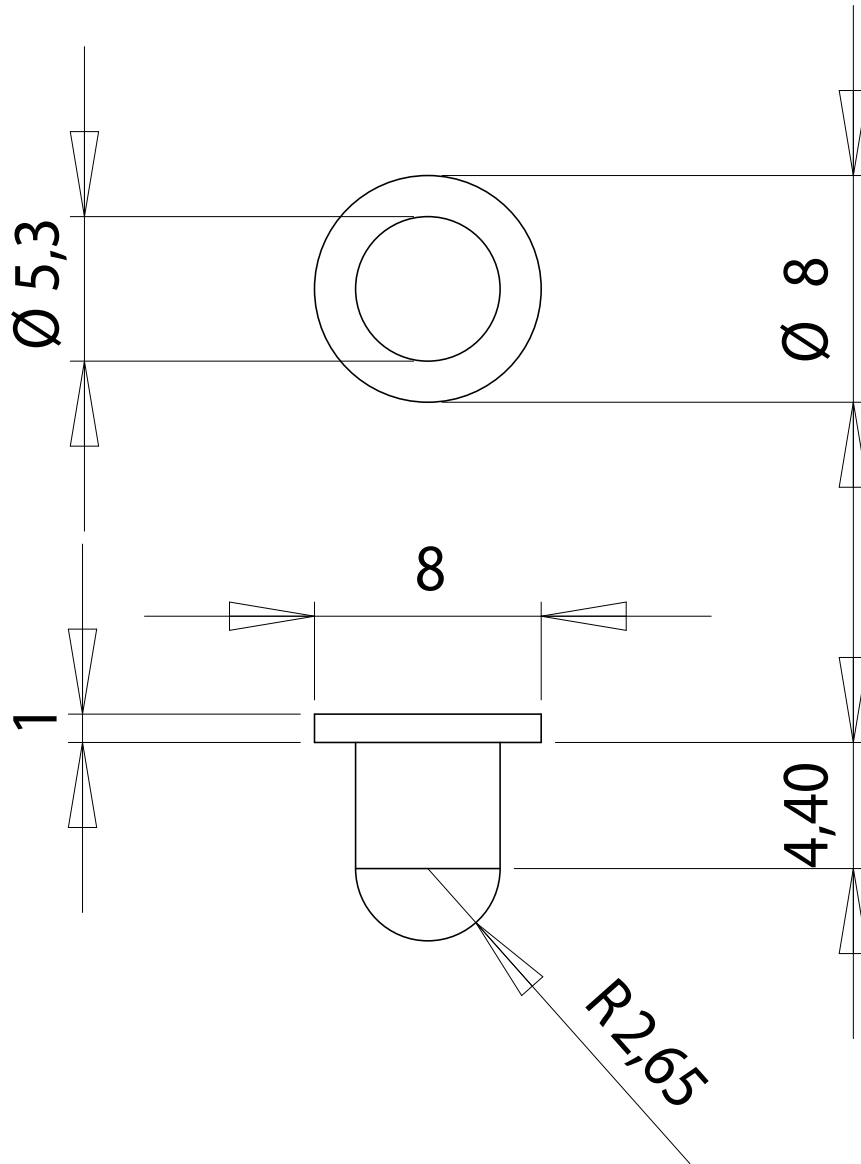

dcw.

Name : LAMP GRAS

Materials : CHROMED STEEL

Part : AXIS

Date :

Rev : 1

Details :

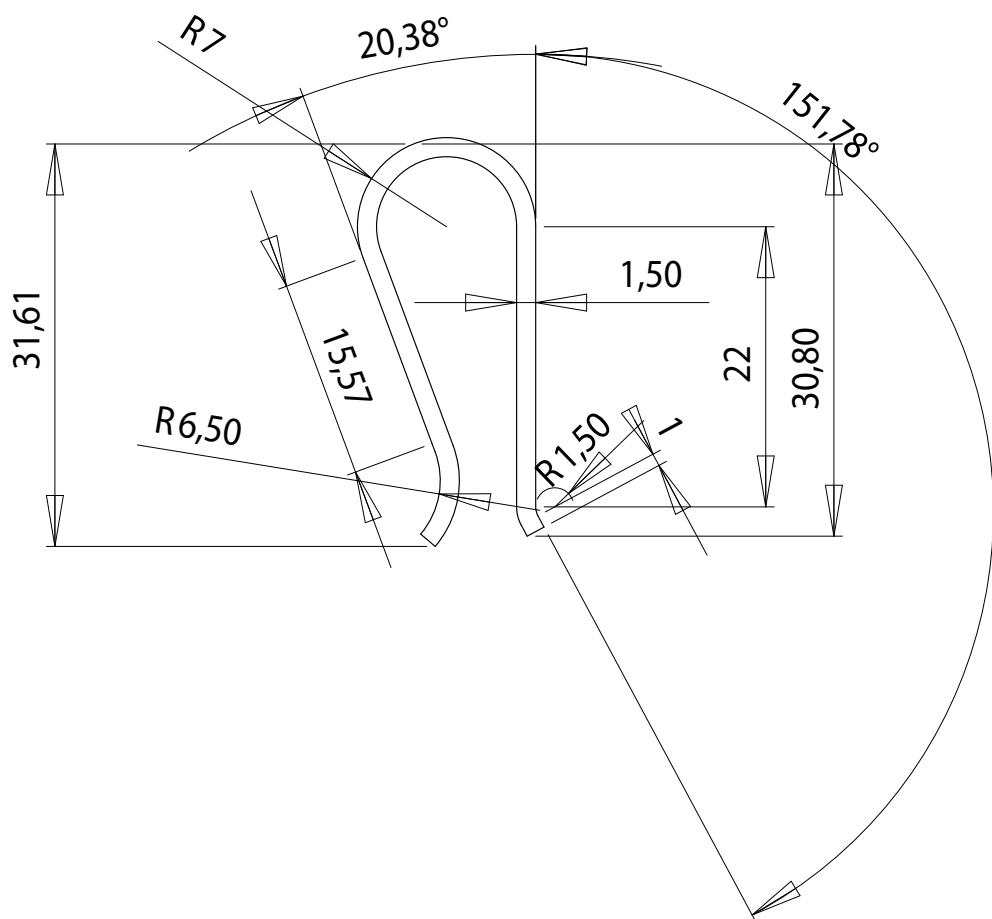
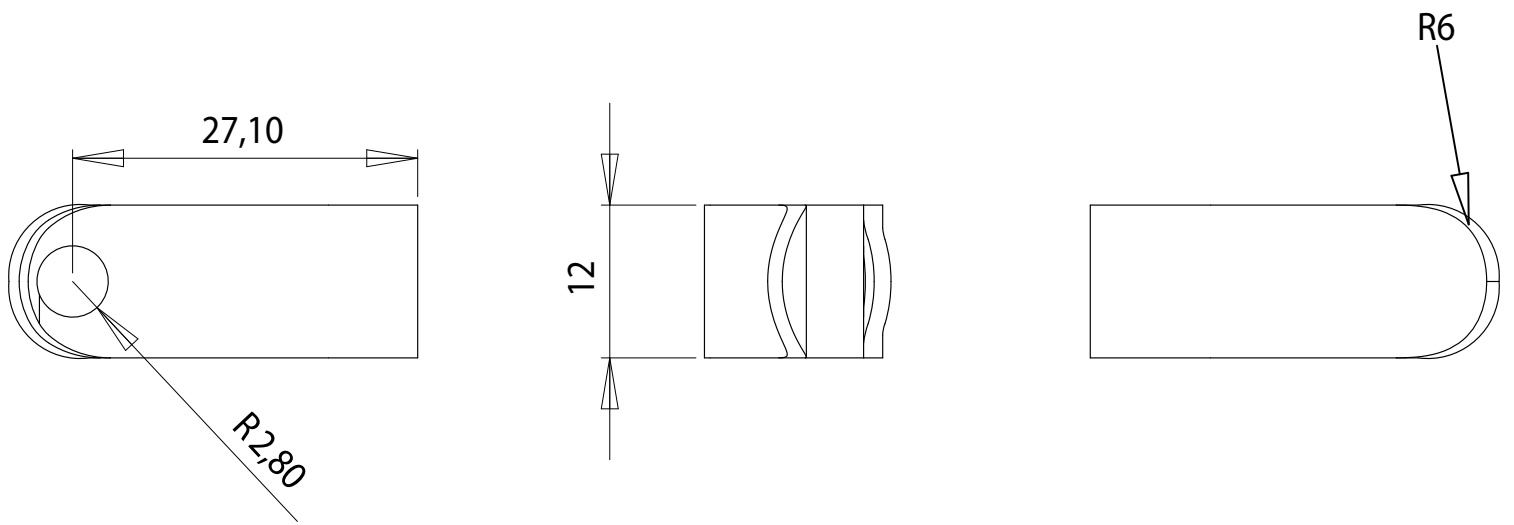

PLIERS SUPPLIED BY DCW

dcw.

Name : LAMP GRAS

Materials : SPRING CHROMED STEEL

Part : PLIERS

Date :

Rev : 1

Details :

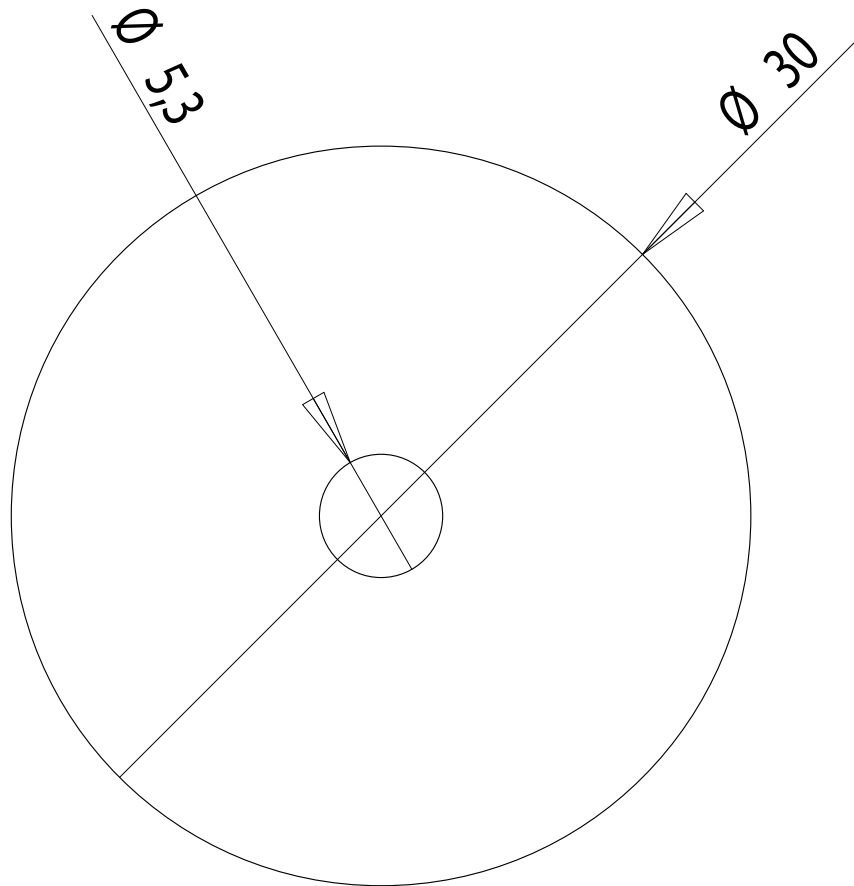
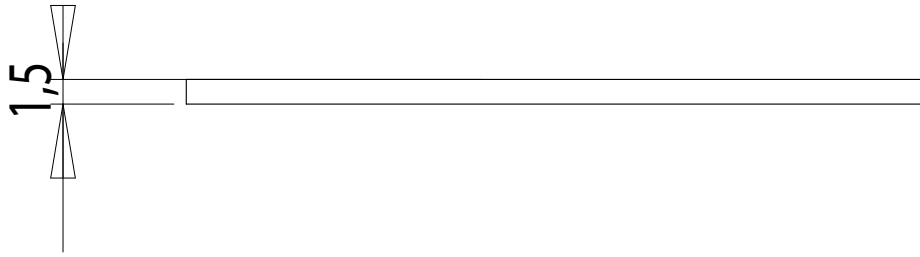

PLIERS SUPPLIED BY DCW

dcw.

Name : LAMP GRAS

Materials : PLASTIC

Part : PLASTIC WASHER – $\varnothing 30$

Date :

Rev : 1

Details :

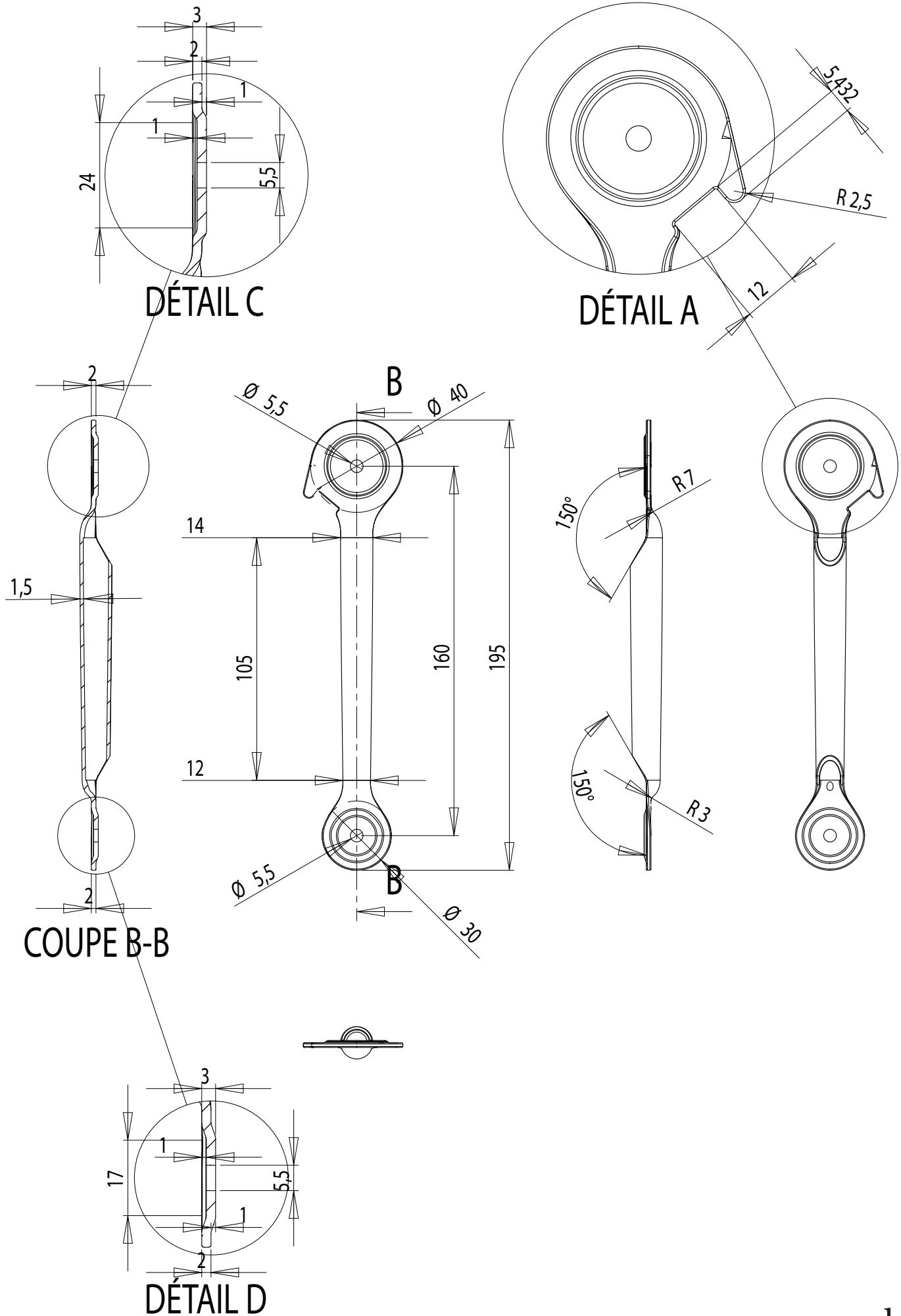

dcw.

Name : **LAMP GRAS**

Materials : PAINTED STEEL/CHROMED STEEL

Part : **TUBE 2**

Date :

Rev : 1

Details :

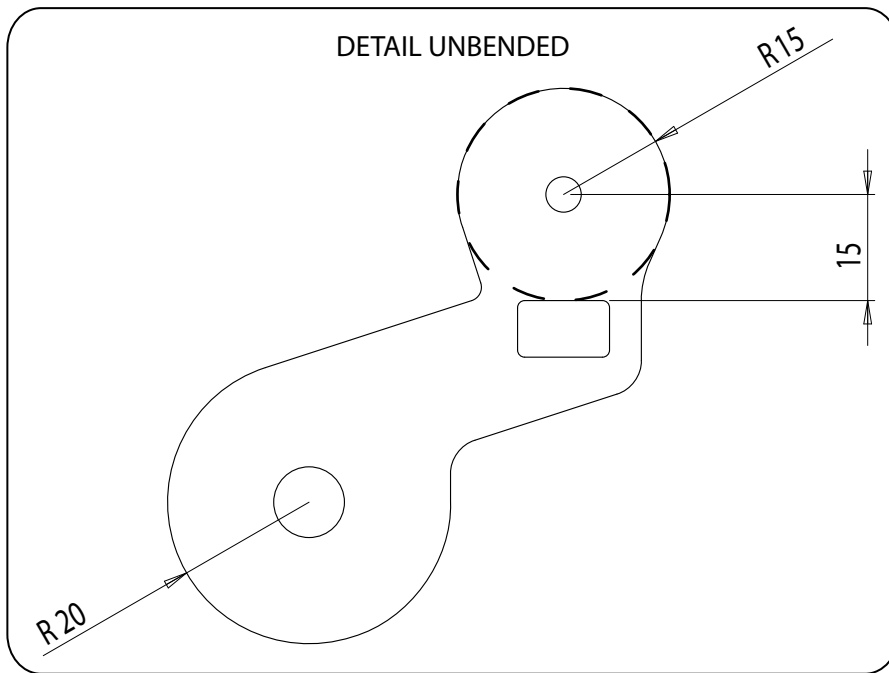
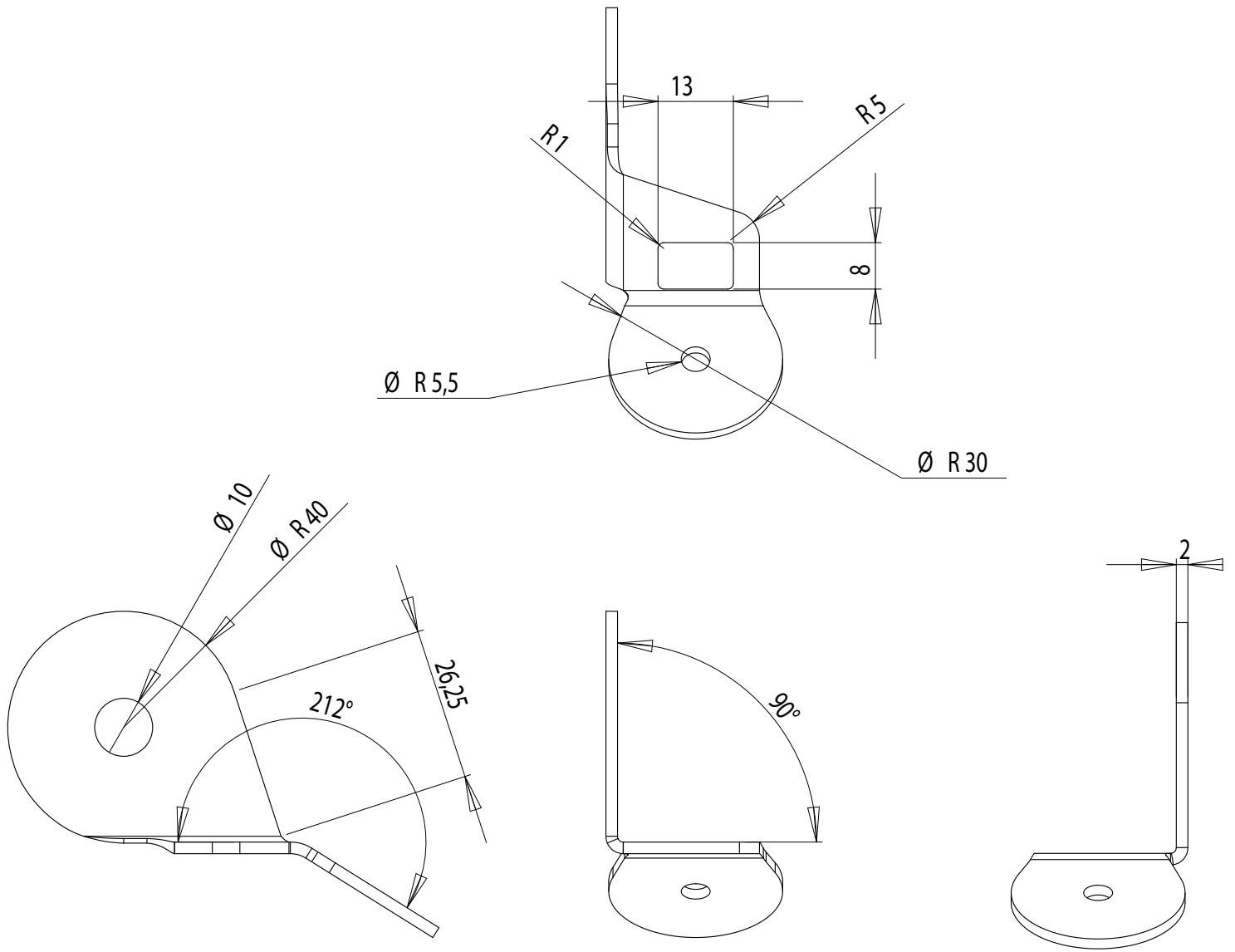

dcw.

Name : **LAMP GRAS**

Materials : PAINTED STEEL / CHROMED STEEL

Part : **JUNCTION PIECE**

Date :

Rev : 1

Details :

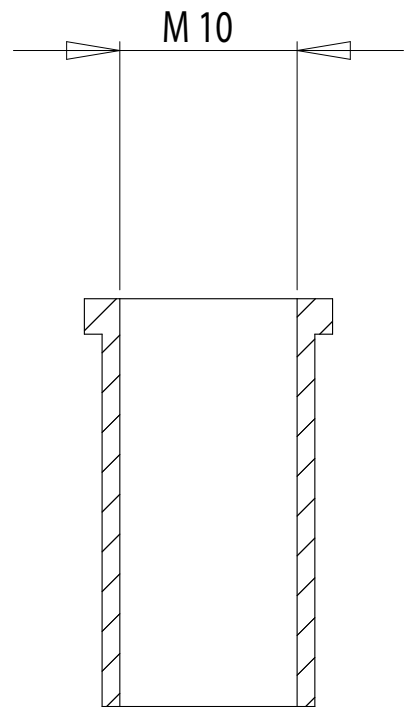
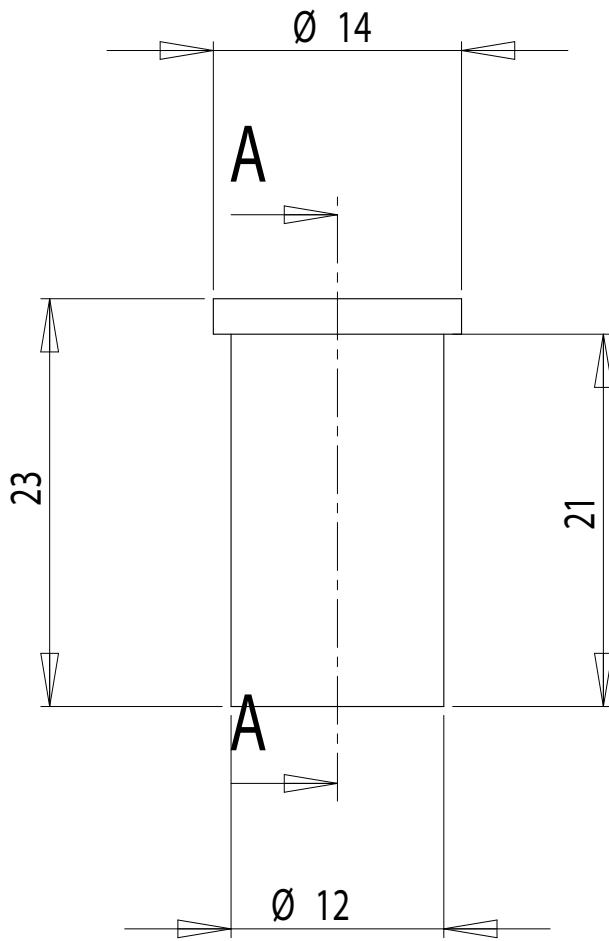

COUPE A-A

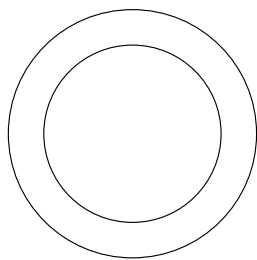

dcw.

Name : LAMP GRAS

Materials : PAINTED STEEL / CHROMED STEEL

Part : FIXATION PIECE

Date :

Rev : 1

Details :

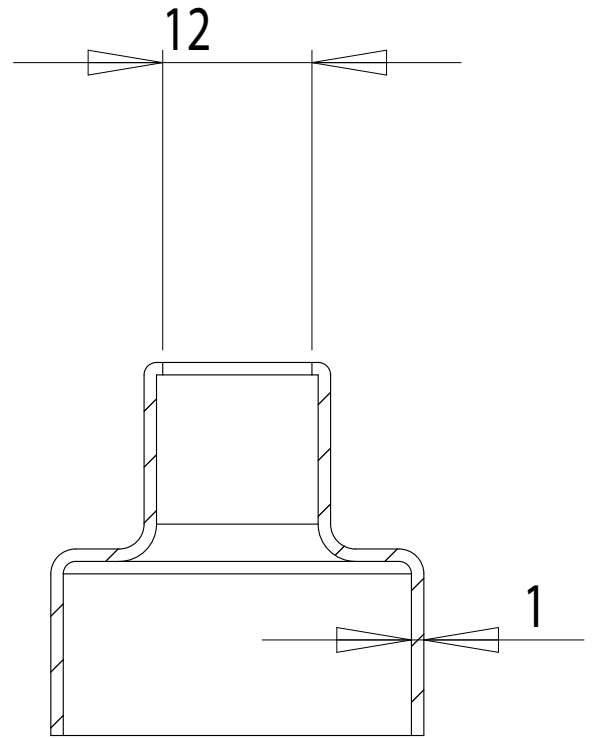
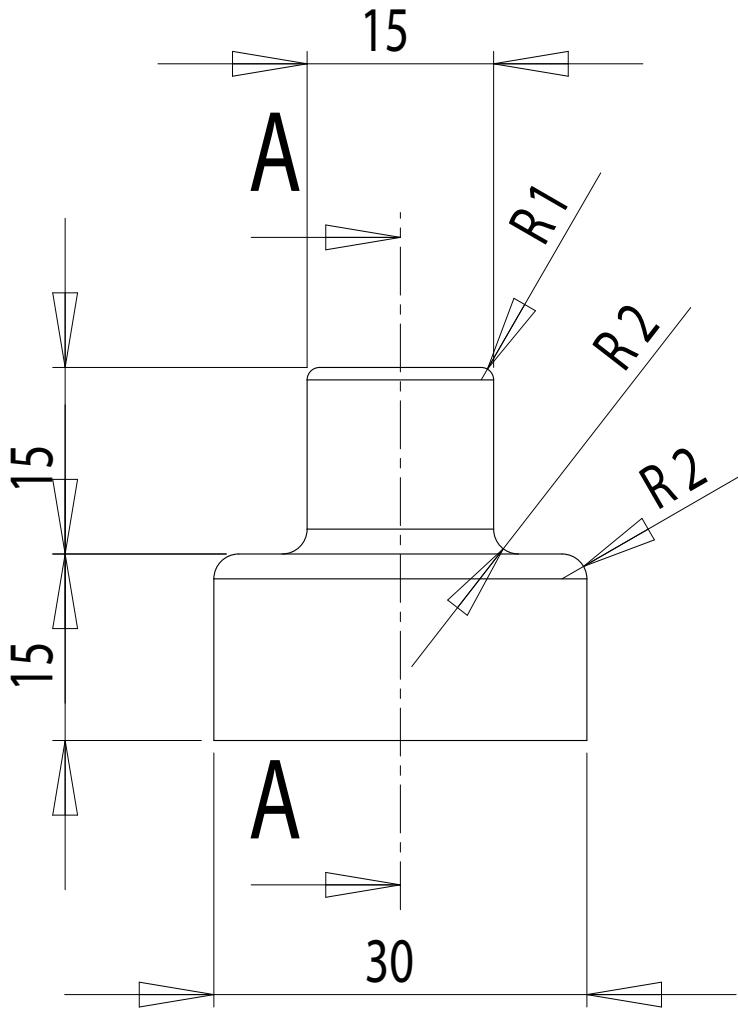

COUPE A-A

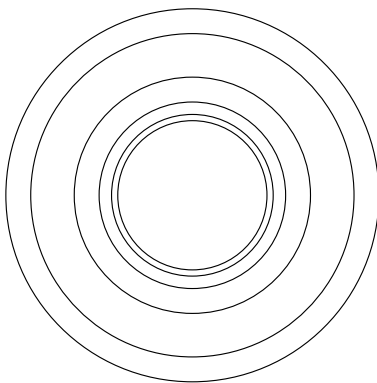

dcw.

Name : **LAMP GRAS**

Materials : PAINTED STEEL / CHROMED STEEL

Part : **COVERING PIECE**

Date :

Rev : 1

Details :

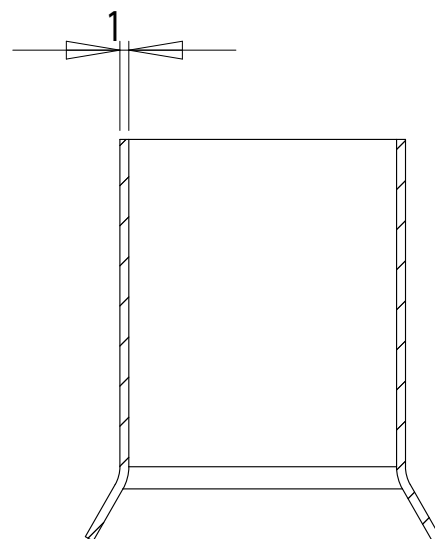
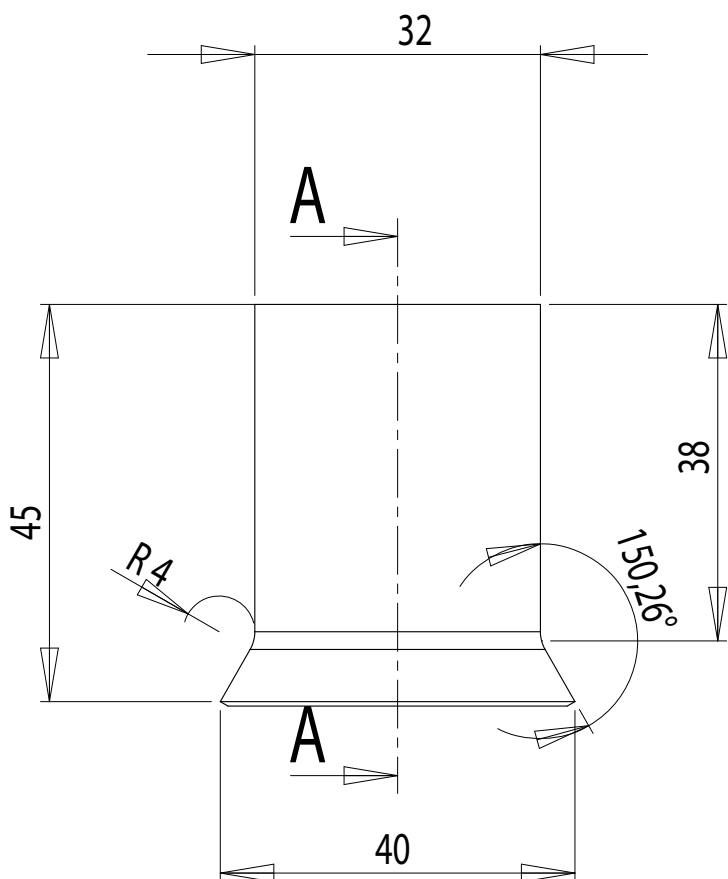
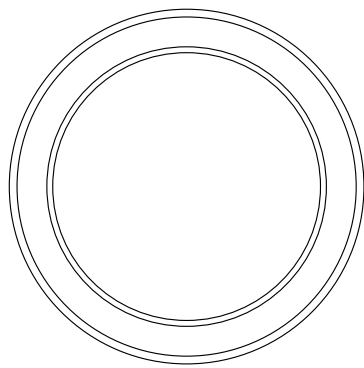

1

COUPE A-A

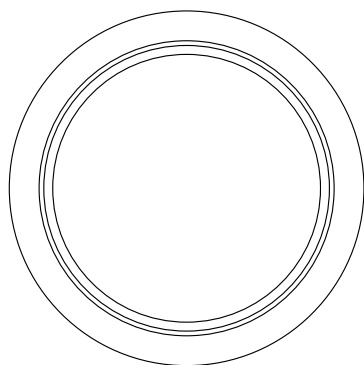

dcw.

Name : **LAMP GRAS**

Matériaux : PAINTED STEEL / CHROMED STEEL

Part : **BULBHOLDER SPACER**

Date :

Rev : 1

Details :

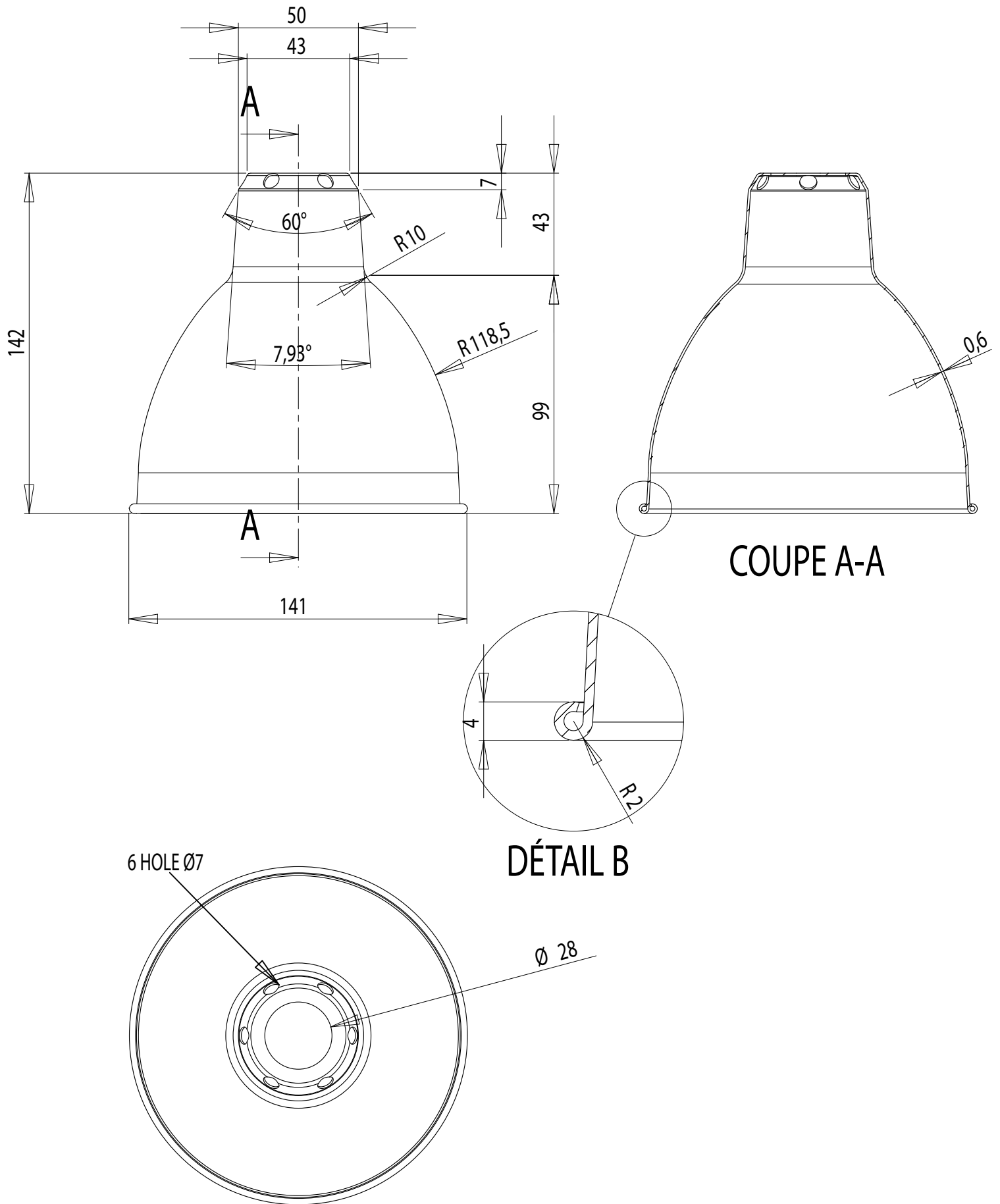

dcw.

Name : **LAMP GRAS**

Materials : PAINTED STEEL/CHROMED STEEL

Part : **ROUND SHADE**

Date :

Rev : 1

Details :