

Qty	Piece	Finishing			
1	WALL PIECE	BLACK SATIN	1	JUNCTION PIECE	BLACK SATIN
1	WALL PIECE 2	BLACK SATIN	1	COVERING PIECE	BLACK SATIN
1	CAST SPRING		1	FIXATION PIECE	BLACK SATIN
1	SPHERE	BLACK	1	ROUND SHADE	BLACK OUTSIDE / WHITE INSIDE
1	BALL BREAKER		1	BULBHOLDER SPACER	CHROME
1	RUBBER	BLACK	1	BULBHOLDER SCREW	CHROME
1	CORD GRIPP	BLACK	1	BULBHOLDER	
1	TUBE 1	BLACK SATIN	3	M10 x 4 NUT	
1	TUBE 2	BLACK SATIN	2	M5 x 5 PLASTIC SCREW	BLACK
1	BREAKING HANDLE	BLACK SATIN	1	THREAD 10X100	
1	PLASTIC WASHER Ø40	RED			
1	PLASTIC WAHSER Ø30	RED			
1	PLIERS	CHROME			
1	AXIS	CHROME			

dcw.

Name : LAMP GRAS N°304 L60 BL-SAT

Matérials :

Part :

Date : 06/02/2013

Rev : 1

Details : E14 - 11w ; Arditi métal bulbholder ; Switch on cast, Black fabric wire

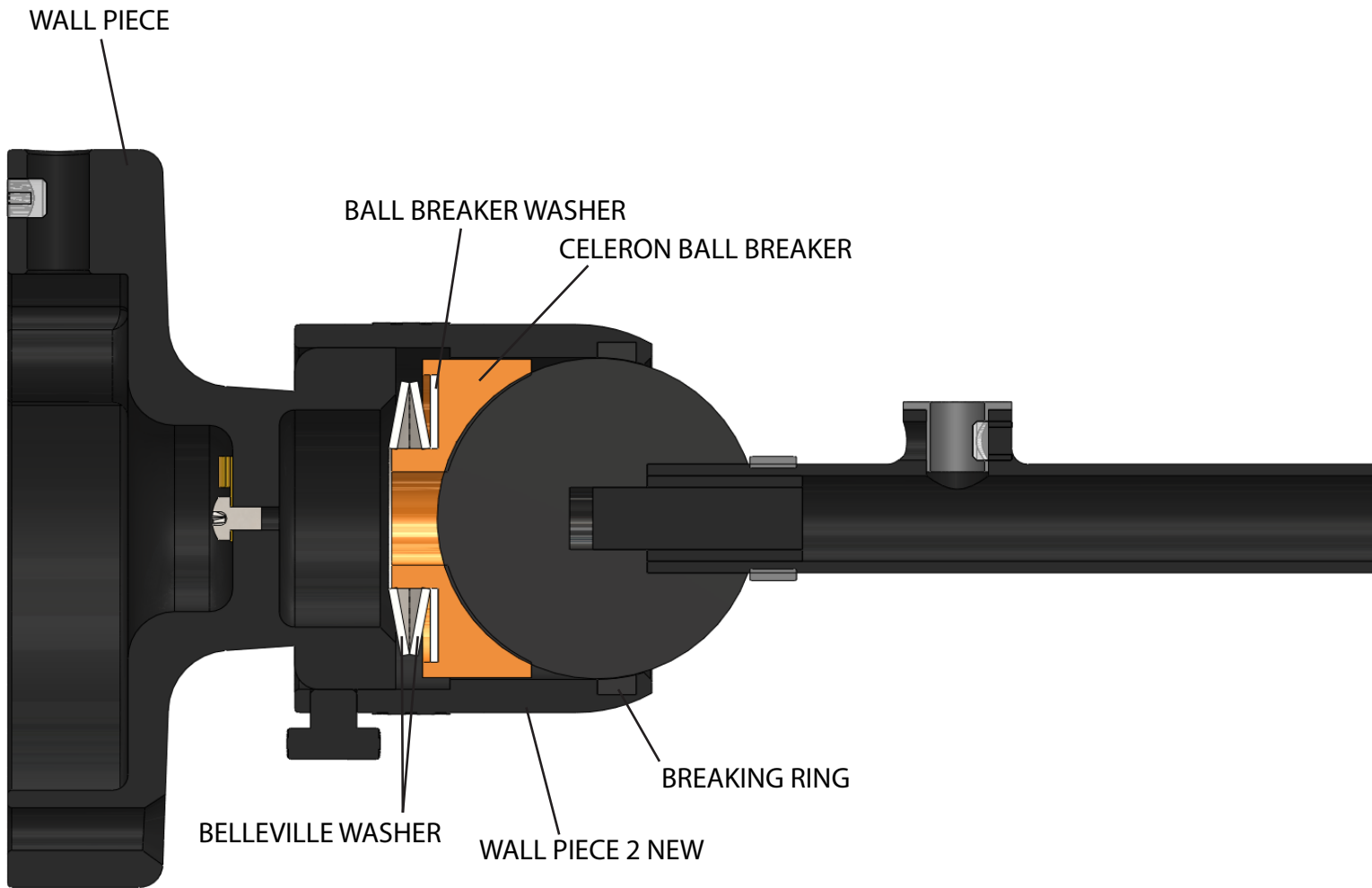

Name : LAMP GRAS N°304

Matériaux :

Part : BREAKING SYSTEM DETAILS

Date :

Rev : 1

Details : E14 - 11w ; Arditì métal bulbholder ; Black fabric wire

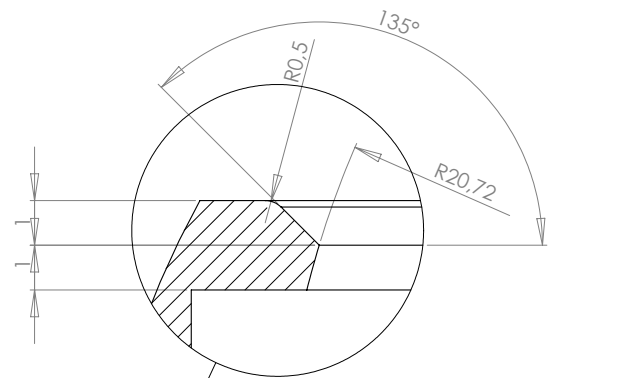
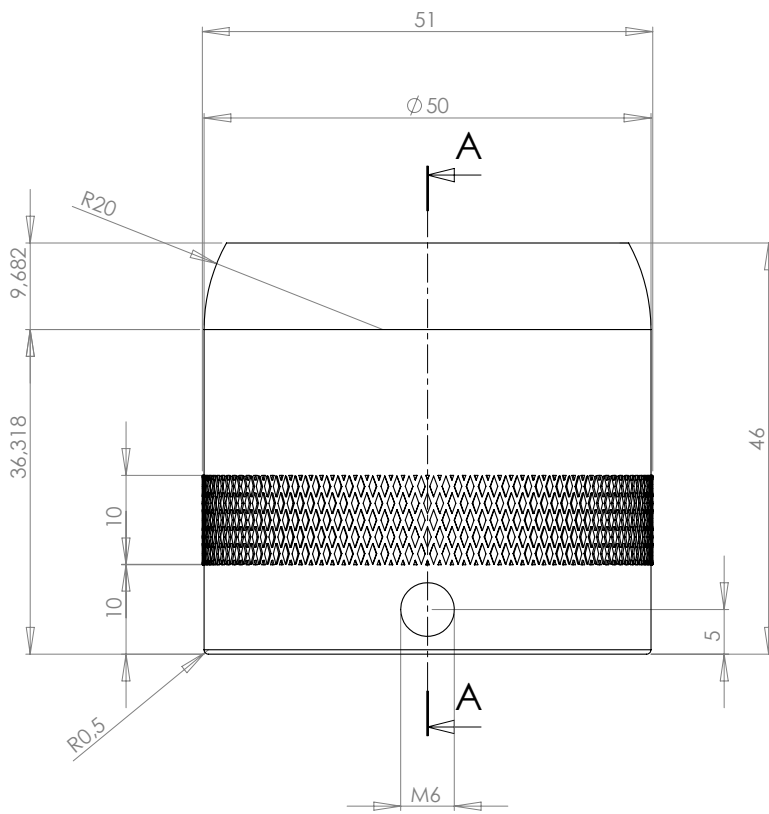
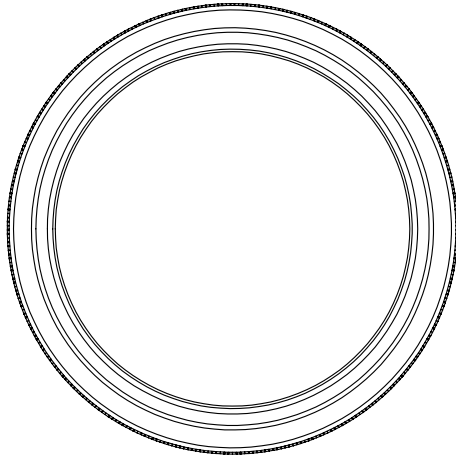

DÉTAIL B

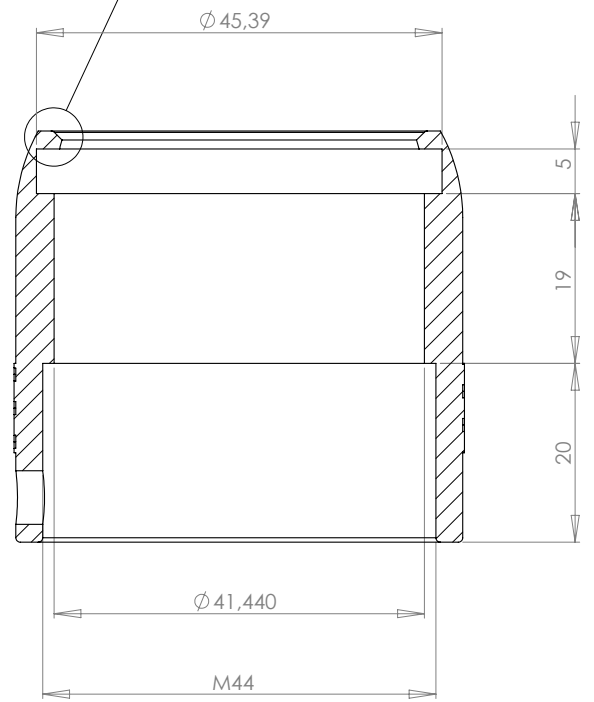

COUPE A-A

dcw.

Name : LAMP GRAS

Materials : PAINTED STEEL

Part : WALL PIECE 2 NEW

Date :

Rev : 1

Details :

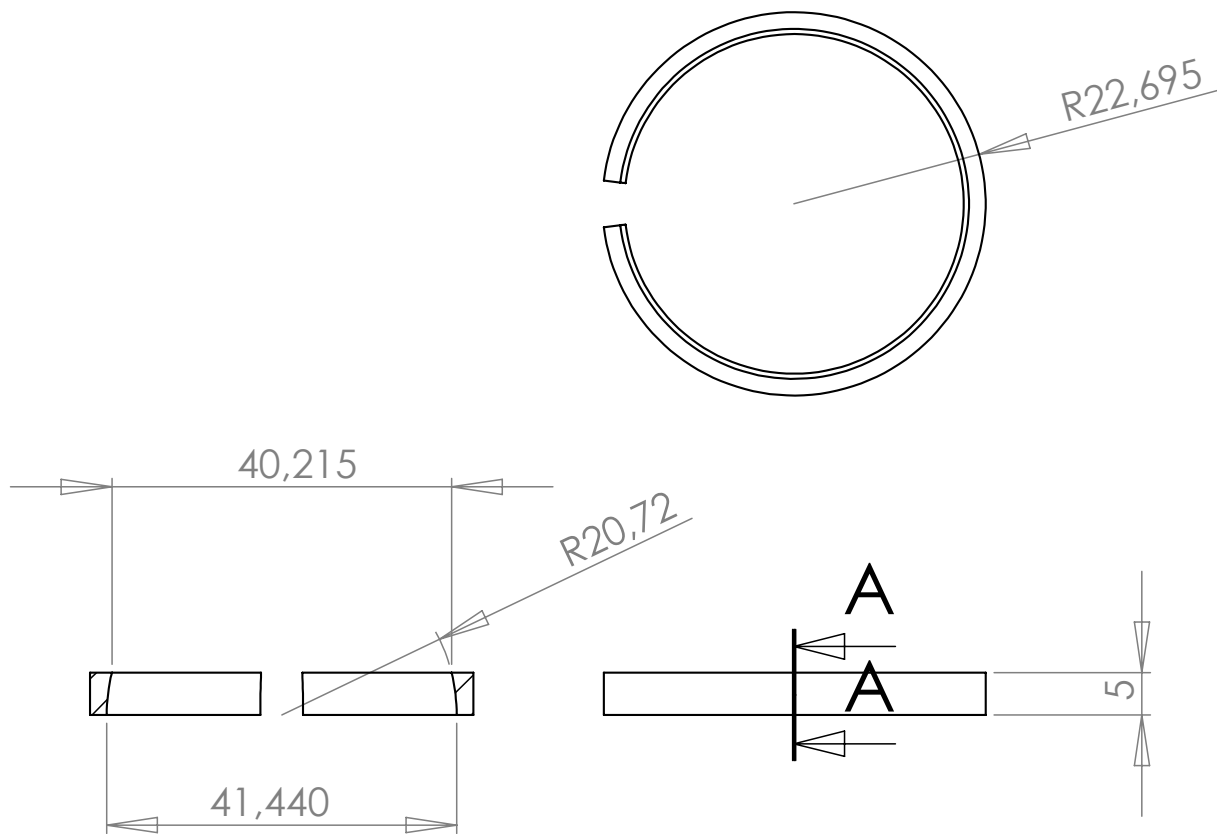

COUPE A-A

dcw.

Name : **LAMP GRAS**

Matériaux : PA 6

Part : **BREAKING RING**

Date :

Rev : 1

Details :



CELERON

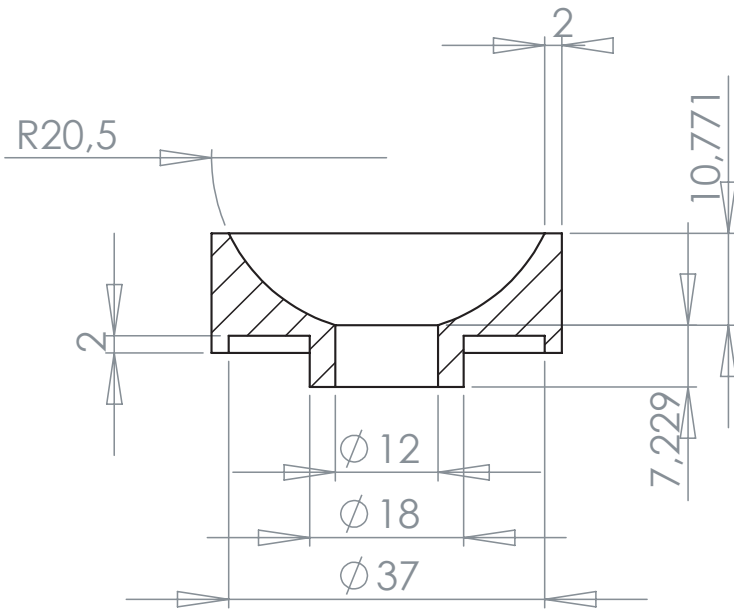
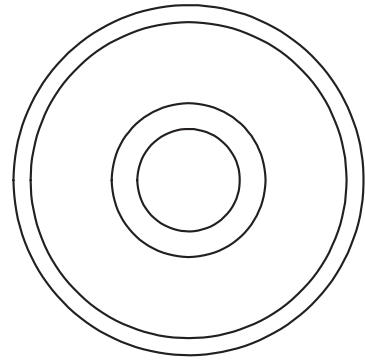

COUPE A-A

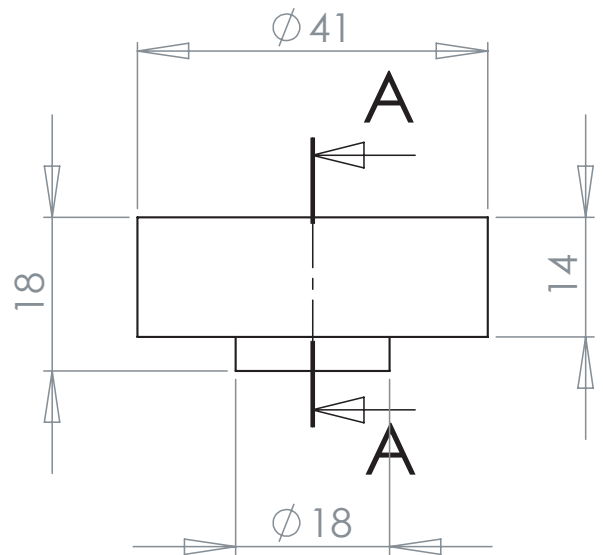

dcw.

Name : LAMP GRAS

Matériaux : CELERON / THERMOPLASTIC RESIN

Part : BALL BREAKER NEW

Date :

Rev : 1

Details :

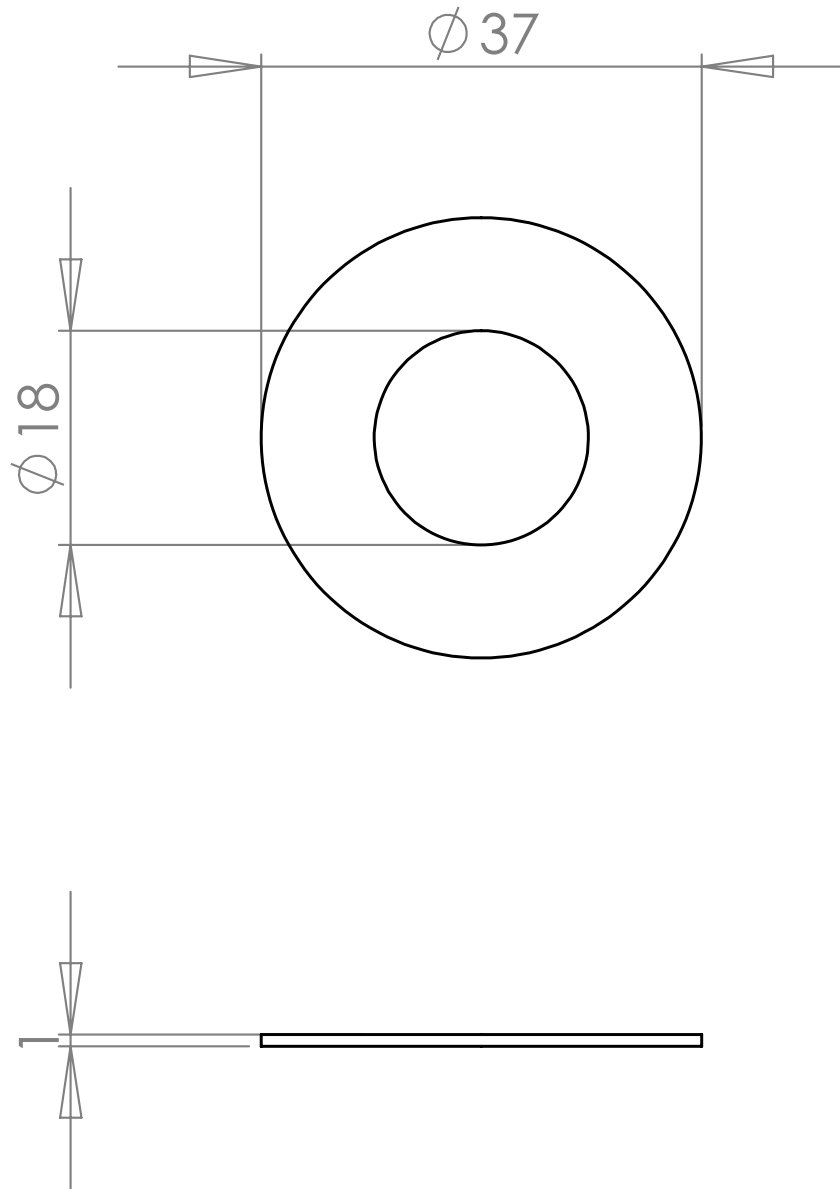

dcw.

Name : **LAMP GRAS**

Materials : STEEL

Part : **BALL BREAKER WASHER**

Date :

Rev : 1

Details :

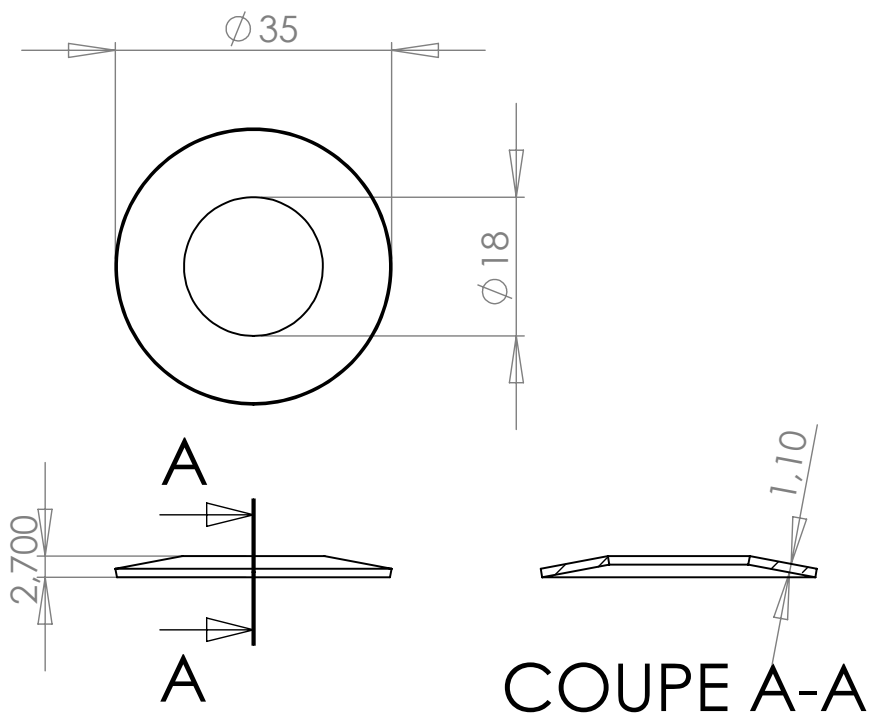

dcw.

Name : LAMP GRAS		Matériaux : SPRING STEEL
Part : BELLEVILLE WASHER		
Date :	Rev : 1	Details :

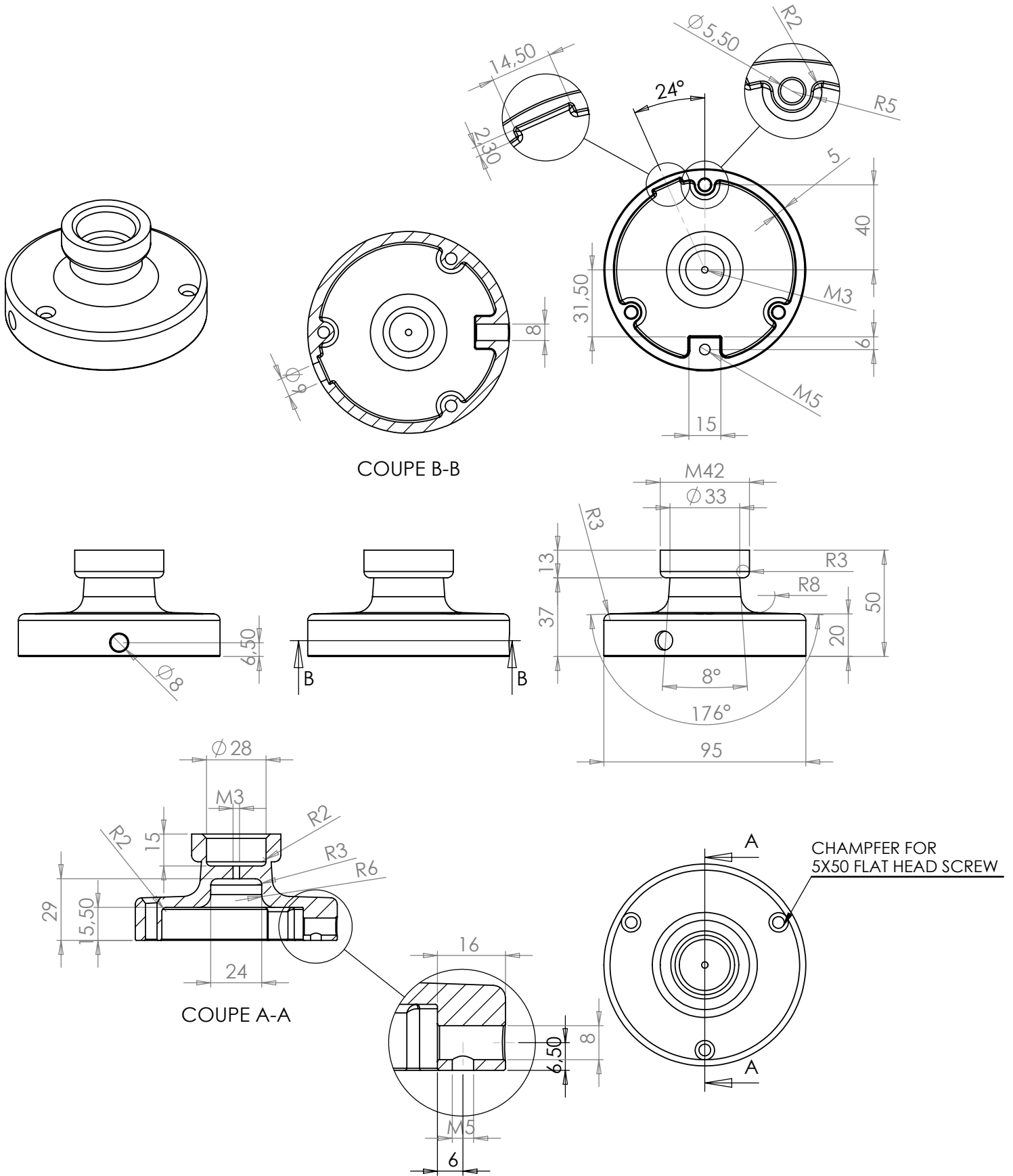

dcw.

Name : LAMP GRAS N°302/304

Materials : PAINTED STEEL

Part : WALL PIECE

Date :

Rev : 1

Details :

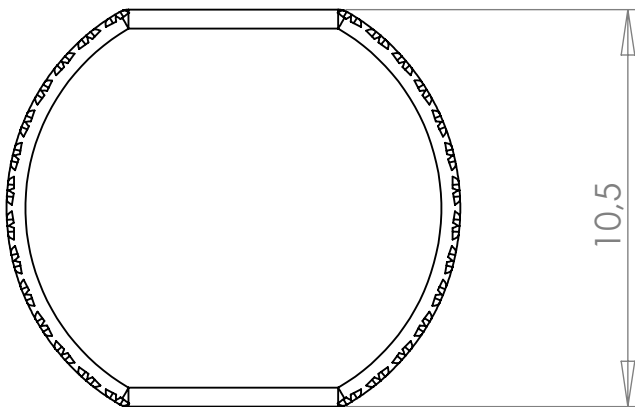
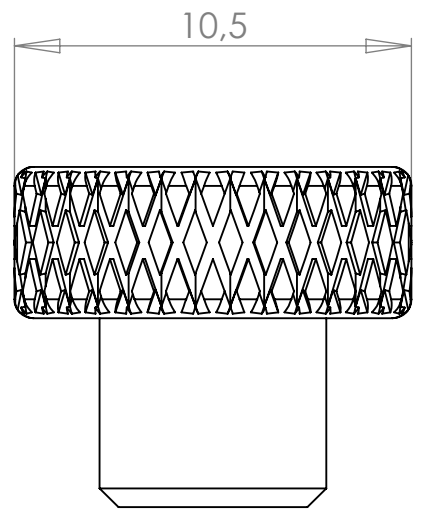
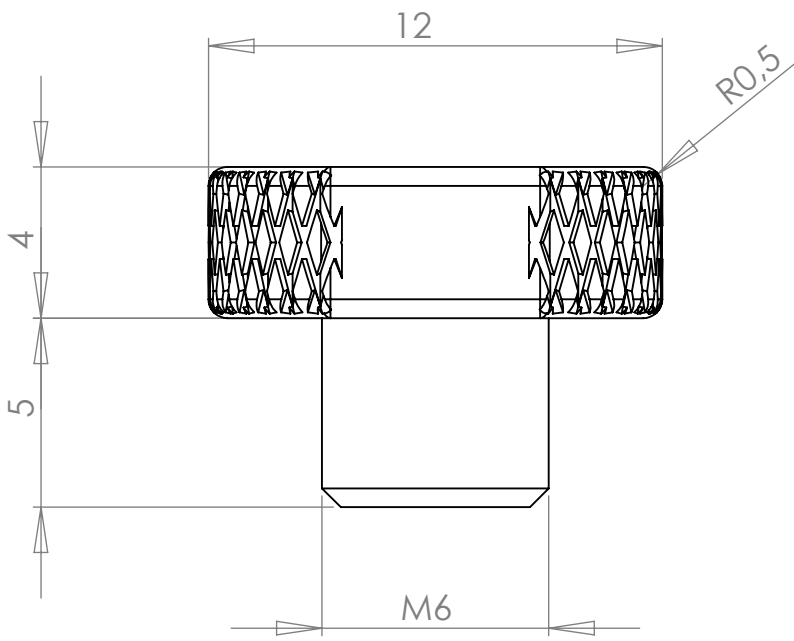
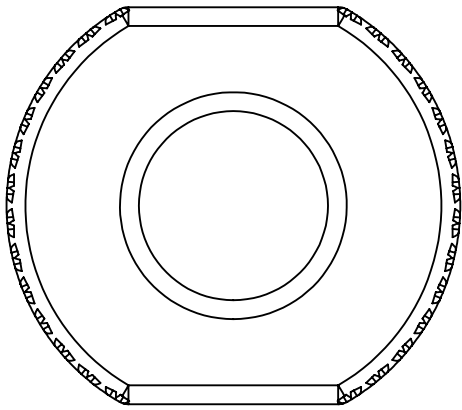

dcw.

Name : LAMP GRAS N°302/304

Materials : PAINTED STEEL

Part : BREAKING HANDLE

Date :

Rev : 2

Details :

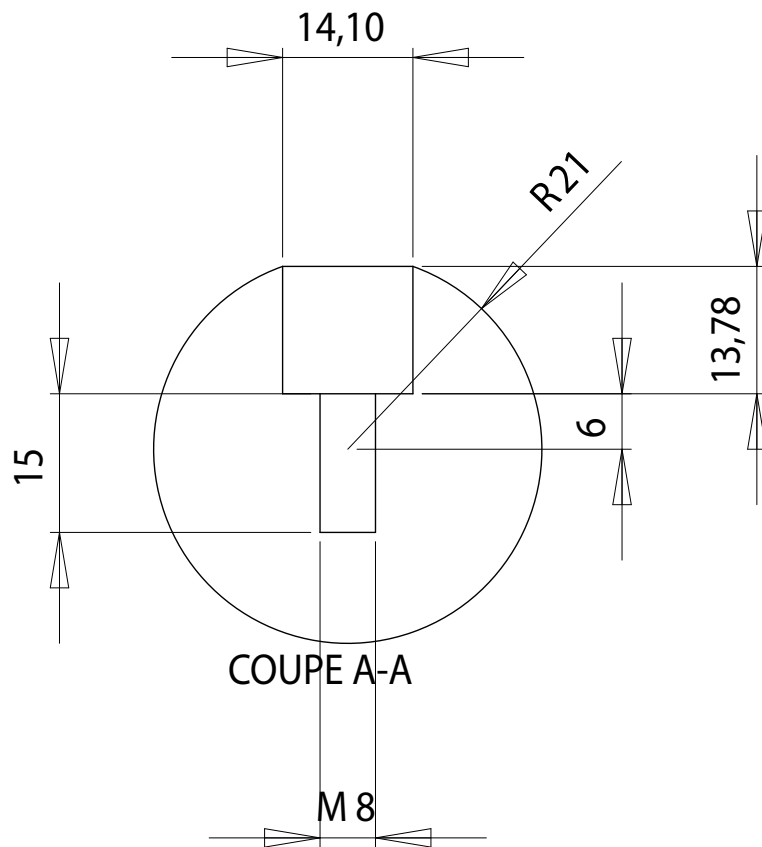
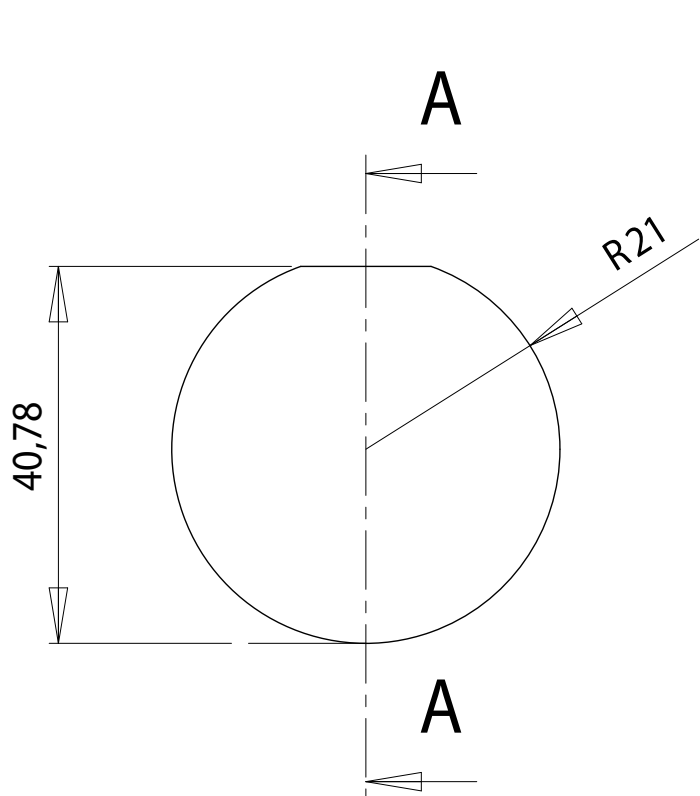

dcw.

Name : LAMP GRAS

Matériaux : BLACK BAKELITE

Part : SPHERE

Date :

Rev : 1

Details :

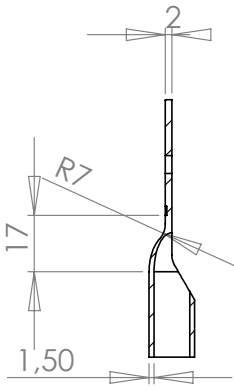

COUPE C-C

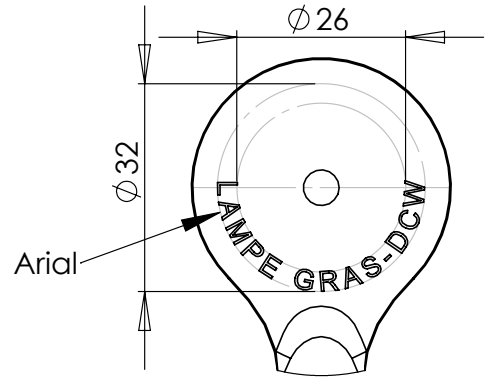

DÉTAIL B

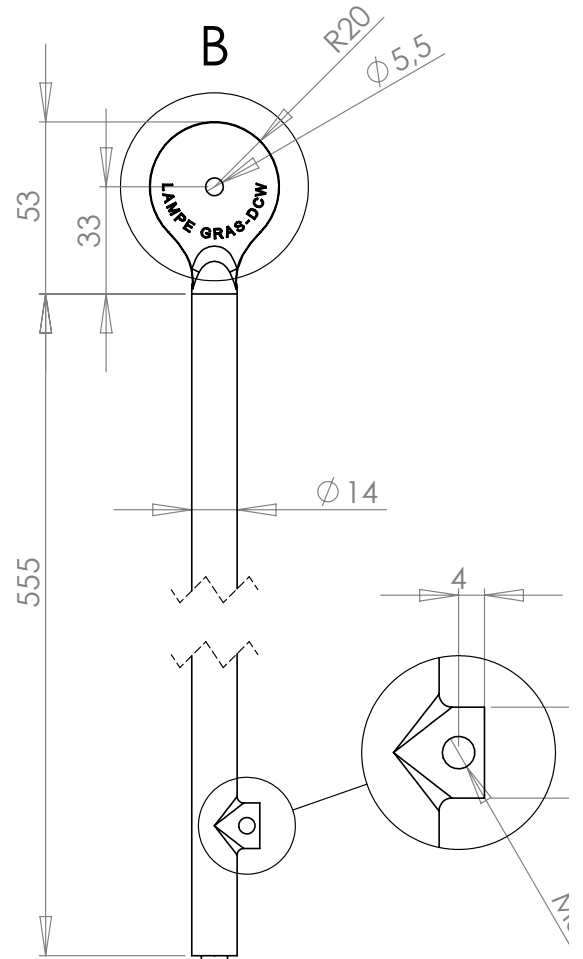
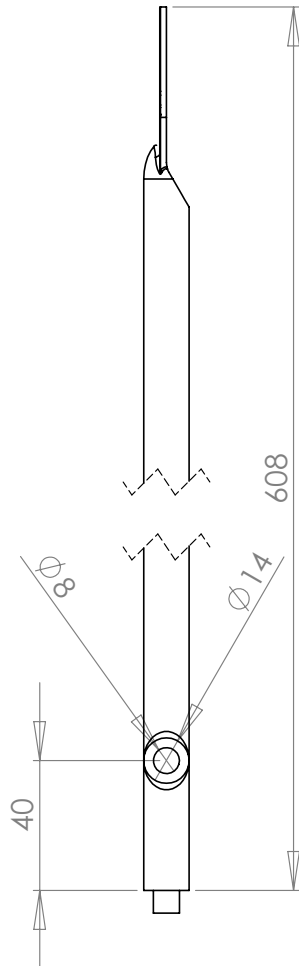
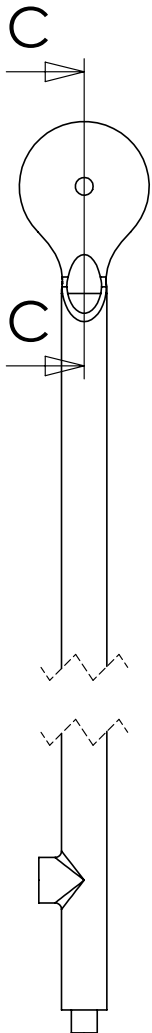

DÉTAIL A

dcw.

Name : LAMP GRAS

Matériaux : PAINTED STEEL / CHROMED STEEL

Part : TUBE 1 – 608

Date :

Rev : 1

Details :

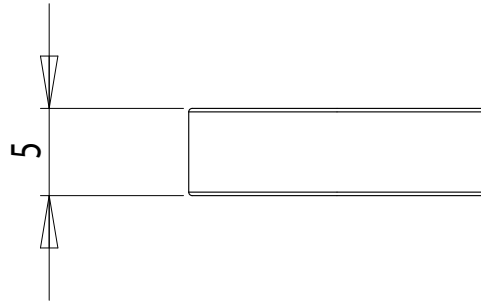
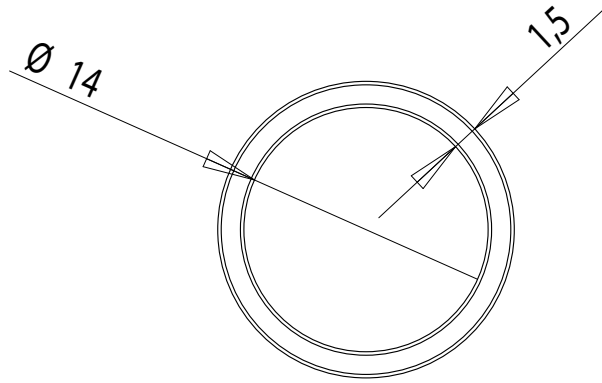

dcw.

Name : LAMP GRAS

Materials : RUBBER

Part : RUBBER

Date :

Rev : 1

Details :

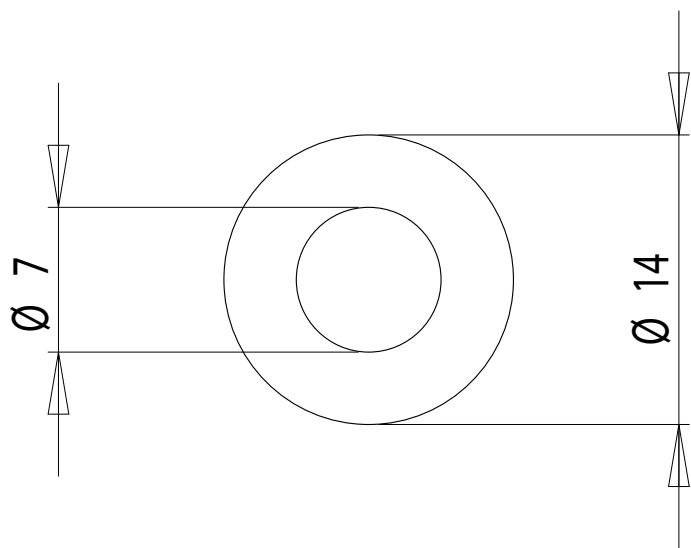
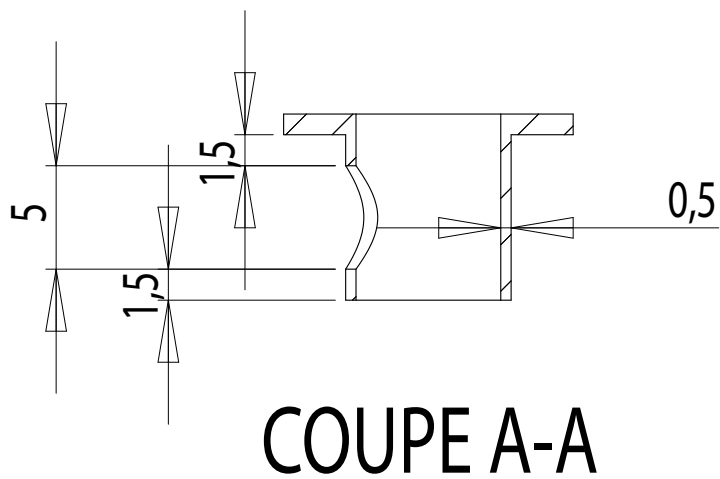
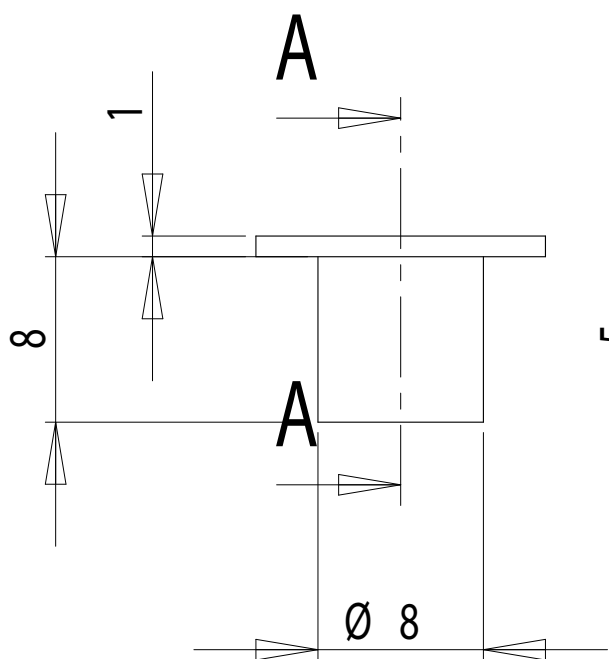
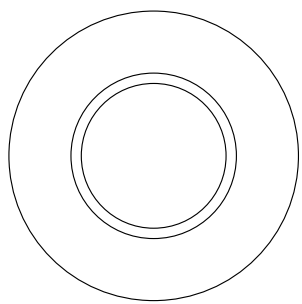

dcw.

Name : LAMP GRAS

Materials : BLACK PLASTIC

Part : CORD GRIPP

Date :

Rev : 1

Details :

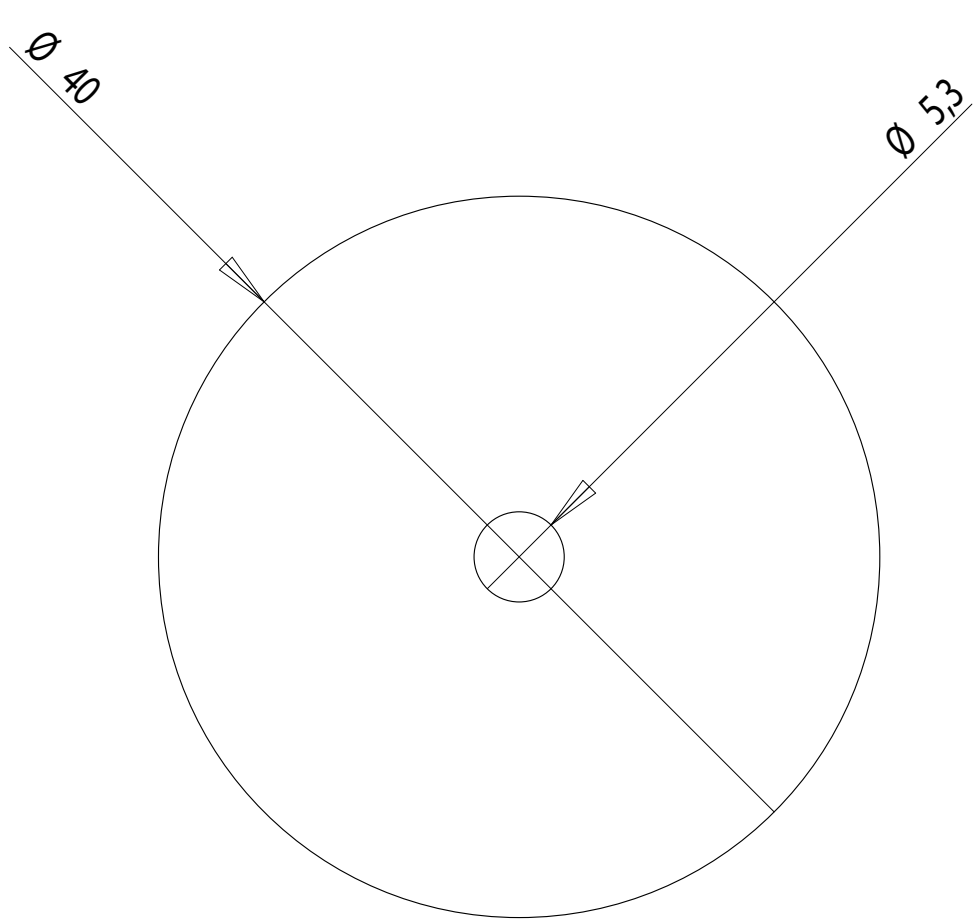

PLIERS SUPPLIED BY DCW

dcw.

Name : LAMP GRAS

Materials : PLASTIC

Part : PLASTIC WASHER – Ø40

Date :

Rev : 1

Details :

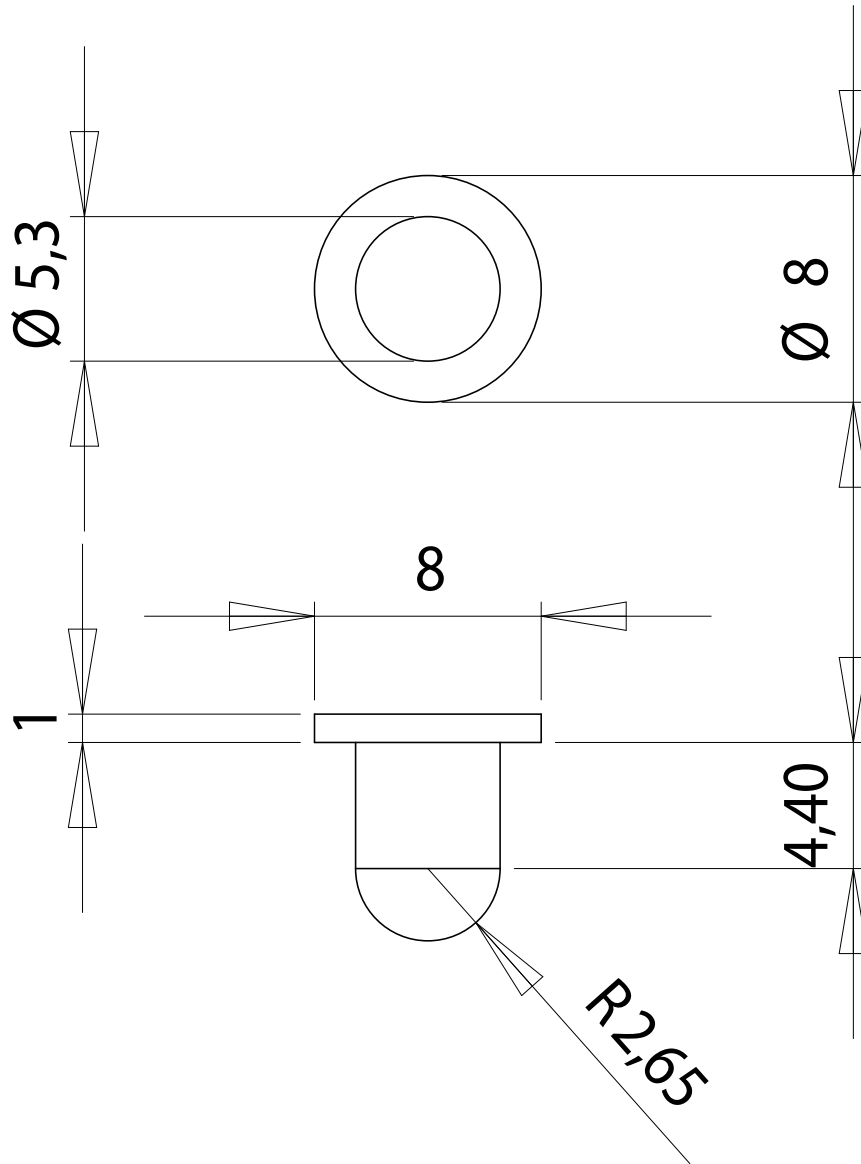

dcw.

Name : LAMP GRAS

Materials : CHROMED STEEL

Part : AXIS

Date :

Rev : 1

Details :

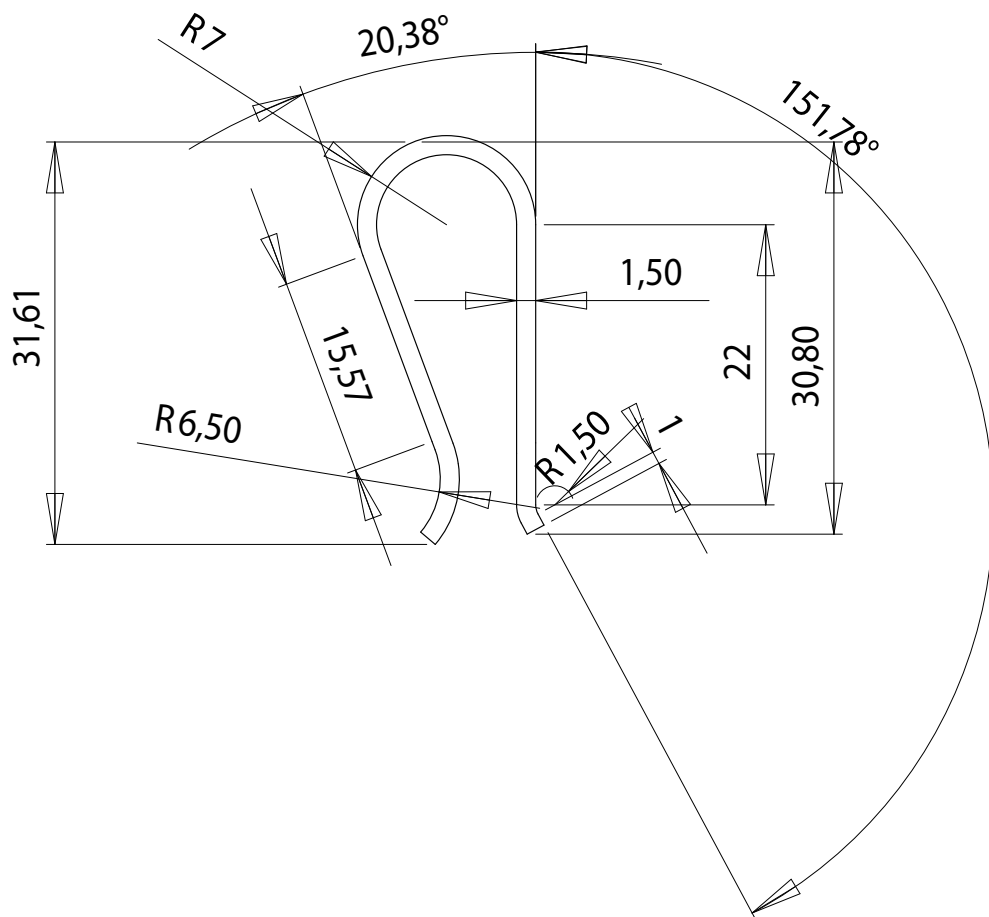
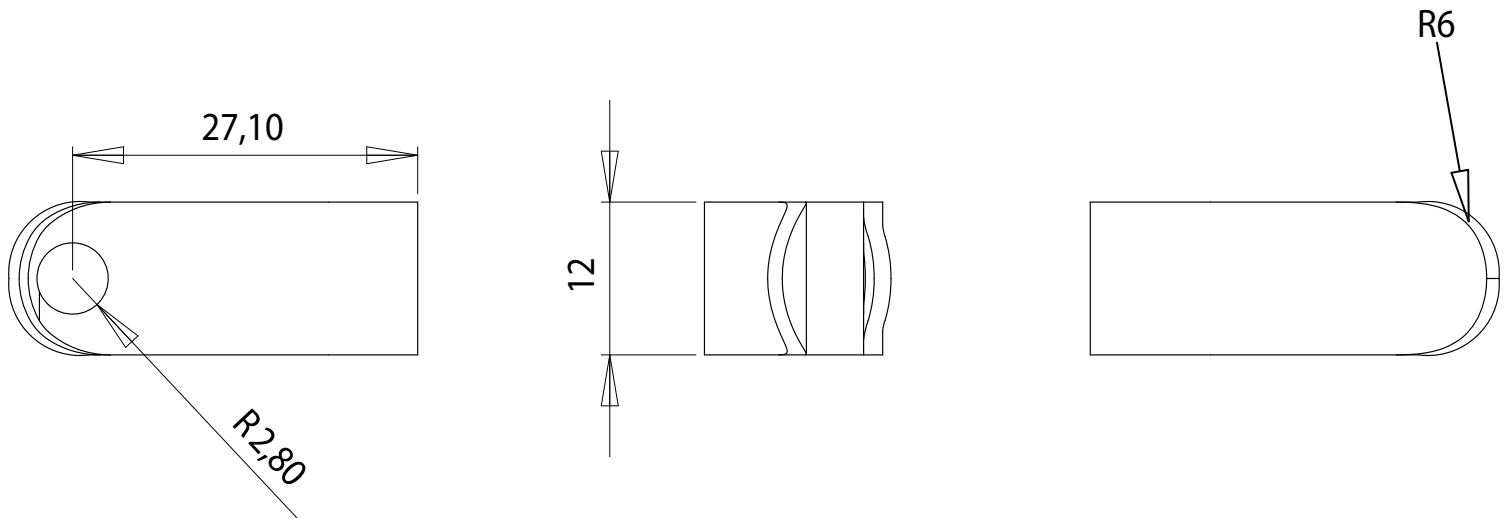

PLIERS SUPPLIED BY DCW

dcw.

Name : LAMP GRAS

Materials : SPRING CHROMED STEEL

Part : PLIERS

Date :

Rev : 1

Details :

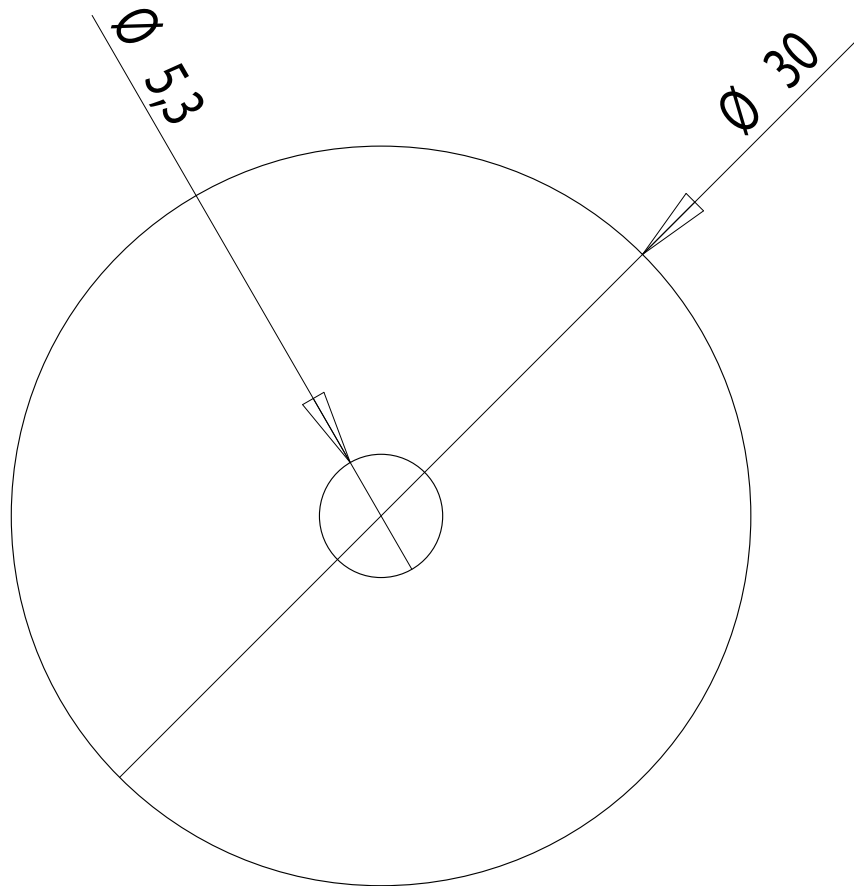
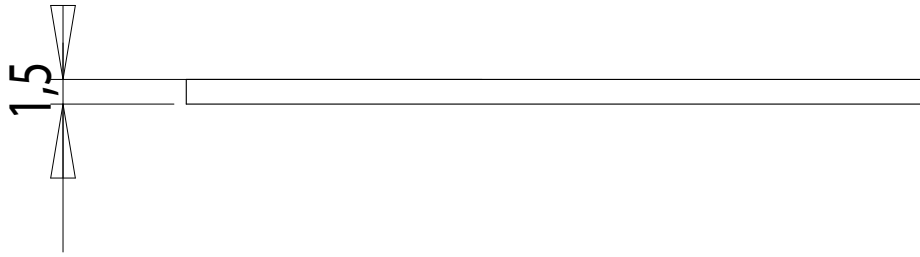

PLIERS SUPPLIED BY DCW

dcw.

Name : LAMP GRAS

Materials : PLASTIC

Part : PLASTIC WASHER – Ø30

Date :

Rev : 1

Details :

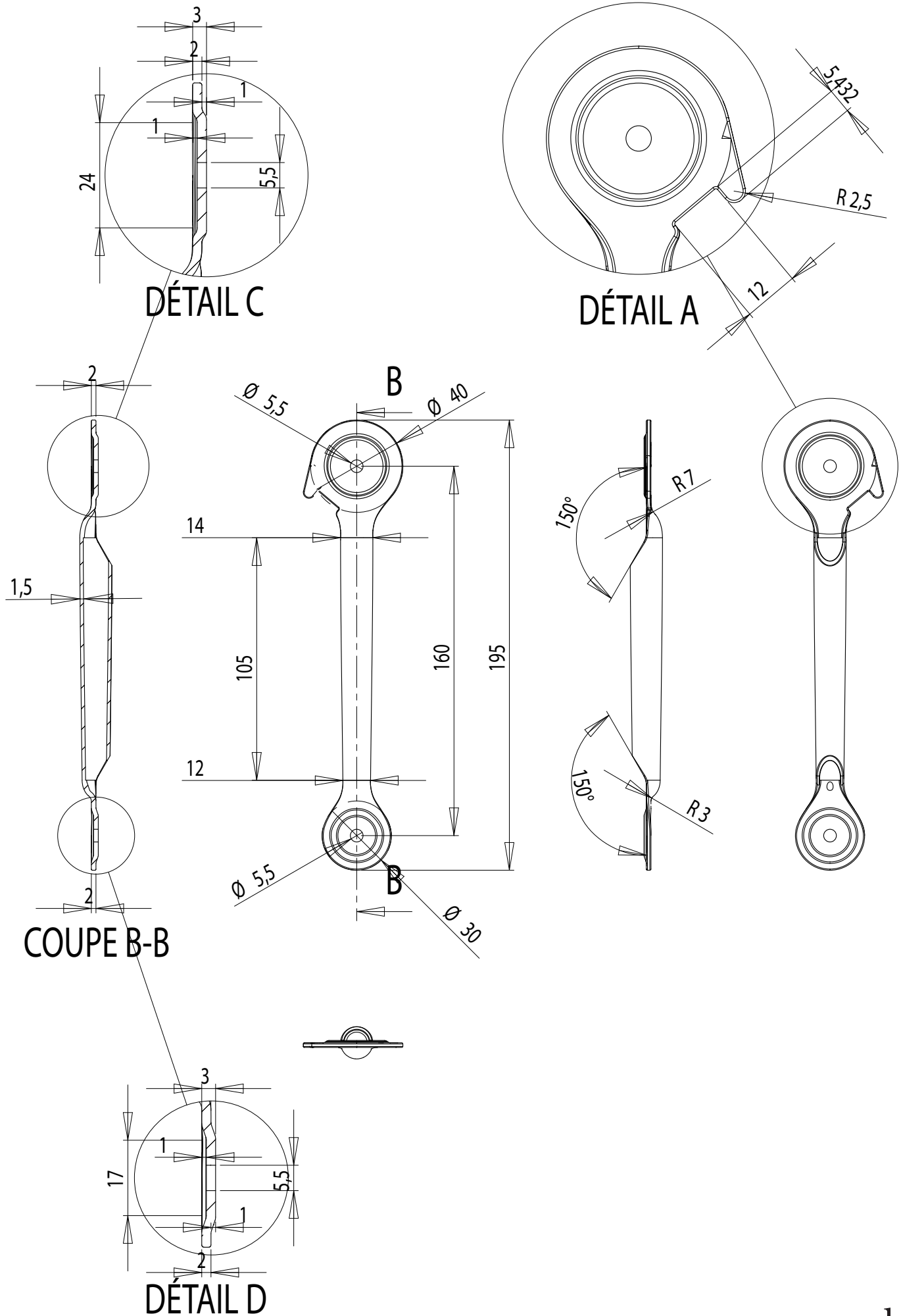

dcw.

Name : LAMP GRAS

Materials : PAINTED STEEL/CHROMED STEEL

Part : TUBE 2

Date :

Rev : 1

Details :

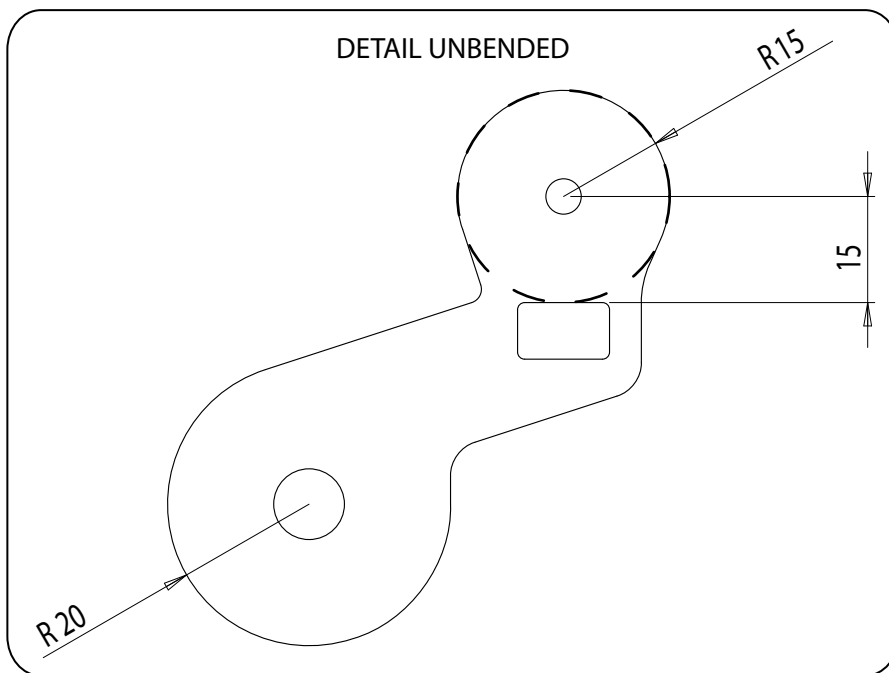
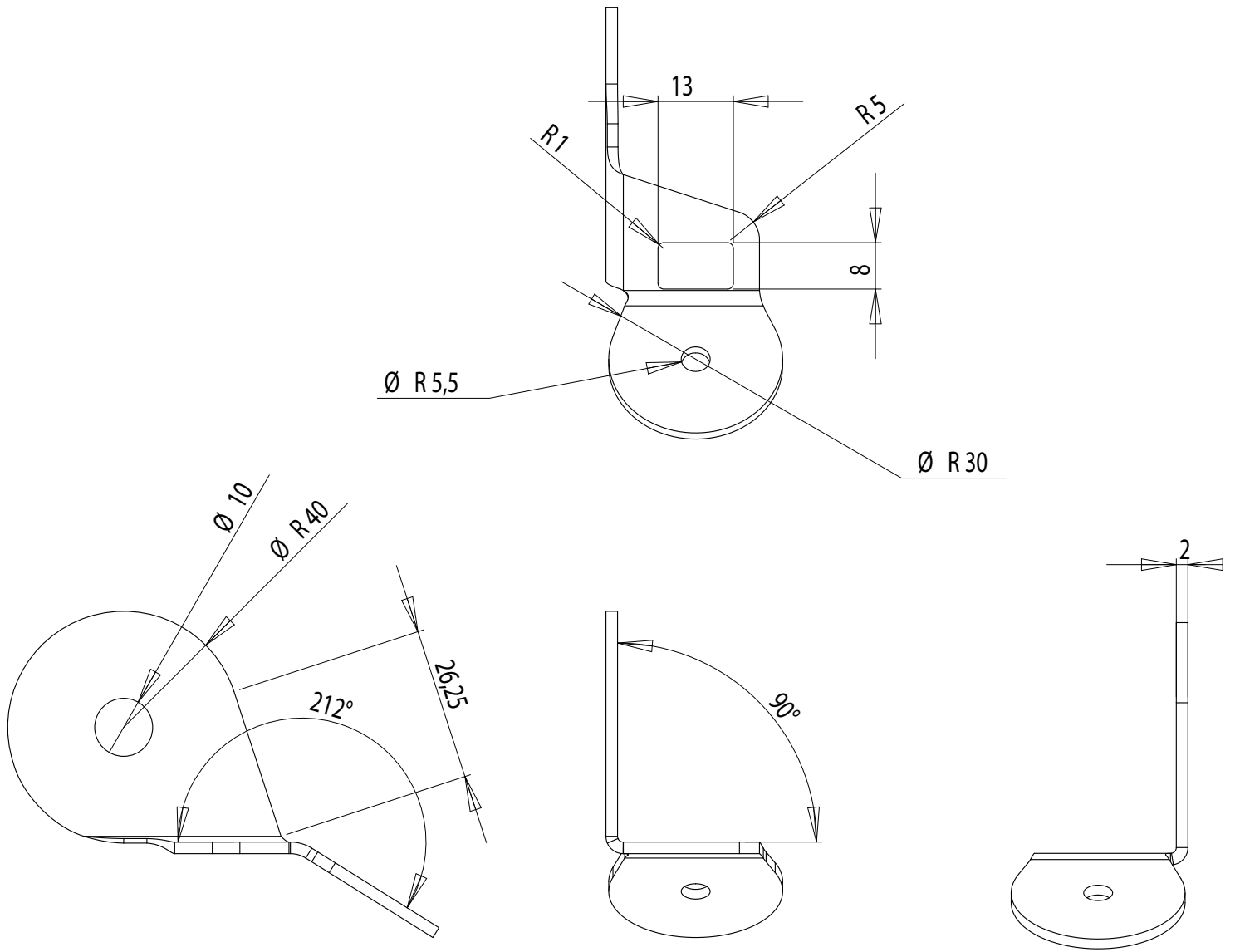

dcw.

Name : **LAMP GRAS**

Materials : PAINTED STEEL / CHROMED STEEL

Part : **JUNCTION PIECE**

Date :

Rev : 1

Details :

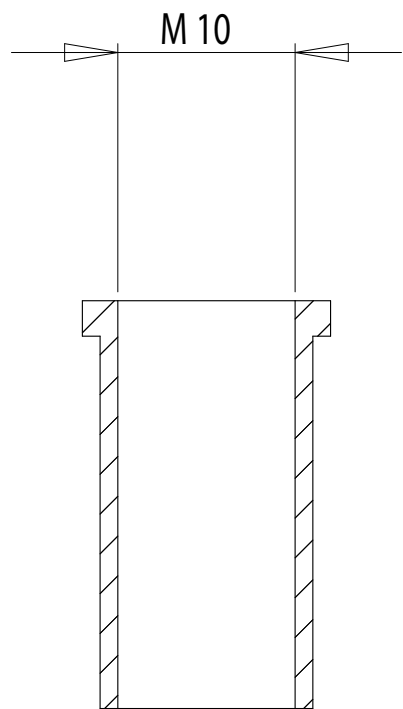
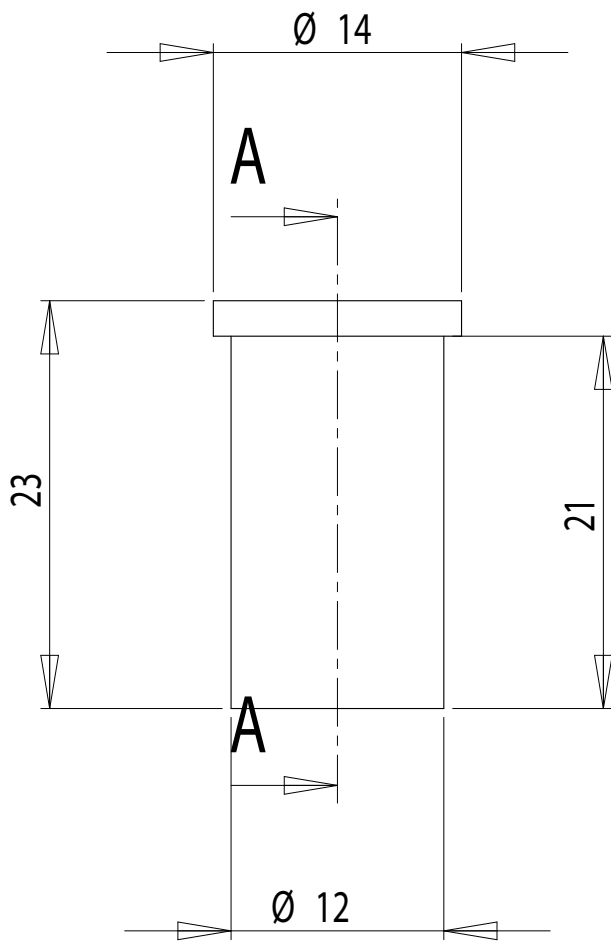

COUPE A-A

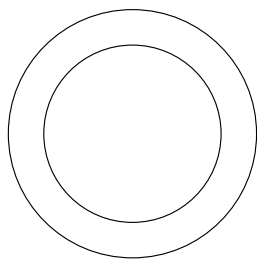

dcw.

Name : **LAMP GRAS**

Part : **FIXATION PIECE**

Date :

Rev : 1

Materials : PAINTED STEEL / CHROMED STEEL

Details :

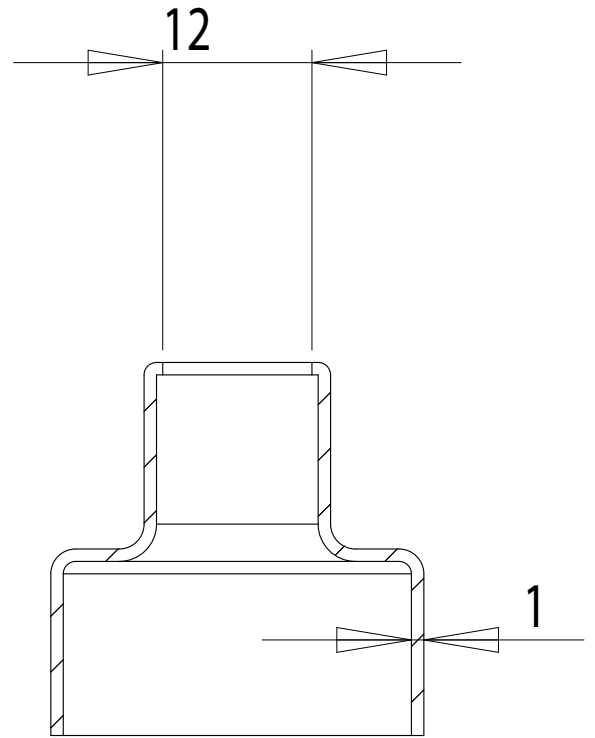
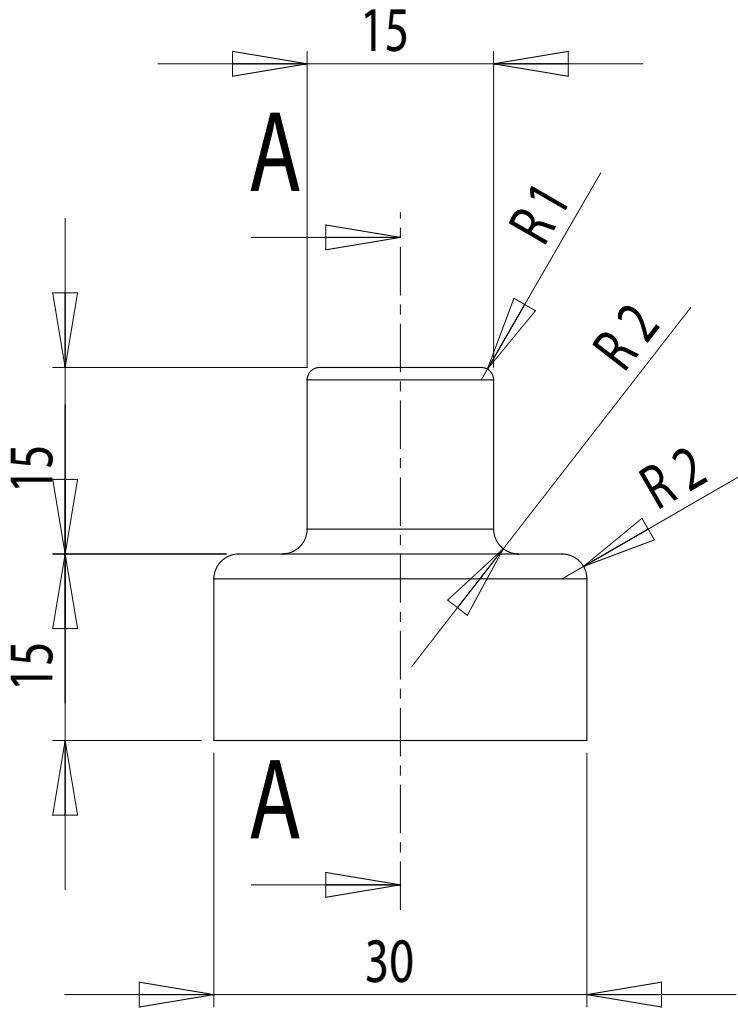

COUPE A-A

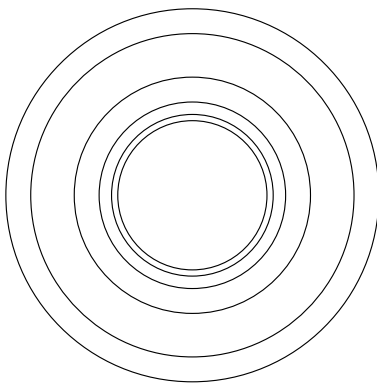

dcw.

Name : **LAMP GRAS**

Materials : PAINTED STEEL / CHROMED STEEL

Part : **COVERING PIECE**

Date :

Rev : 1

Details :

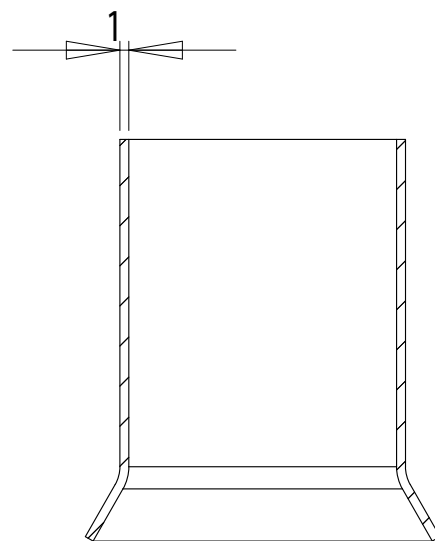
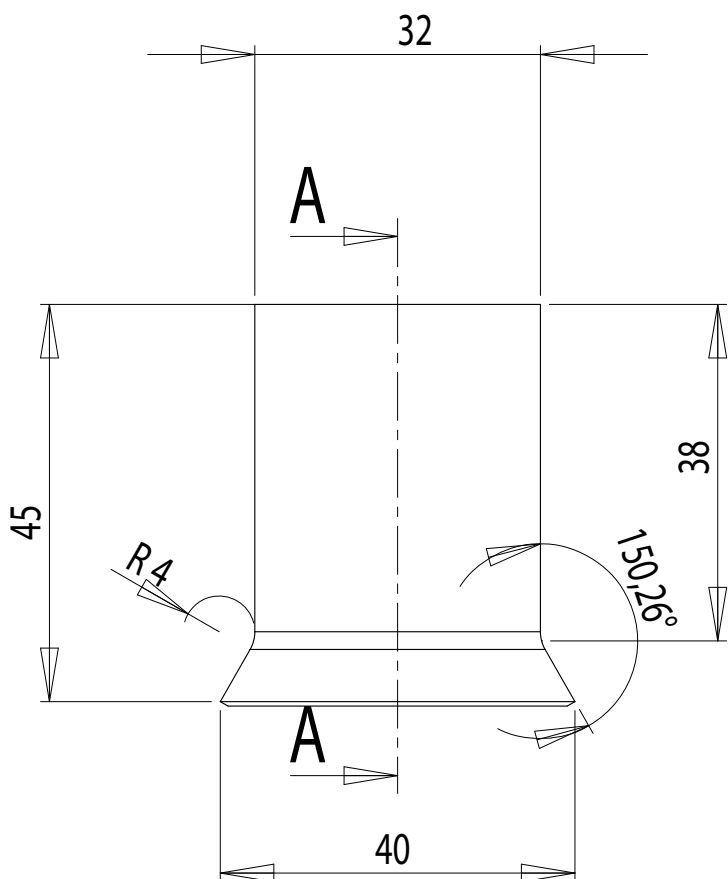
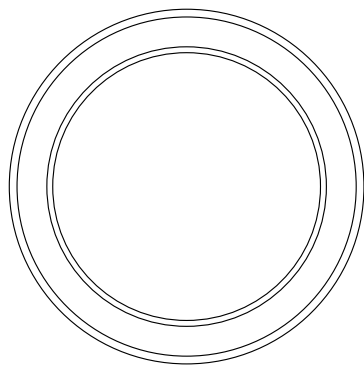

COUPE A-A

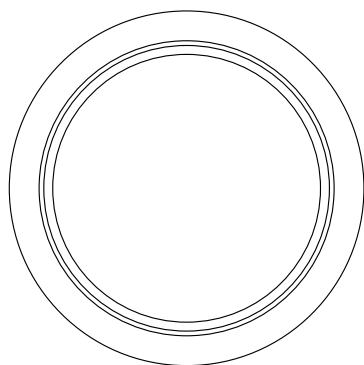

dcw.

Name : **LAMP GRAS**

Materials : PAINTED STEEL / CHROMED STEEL

Part : **BULBHOLDER SPACER**

Date :

Rev : 1

Details :

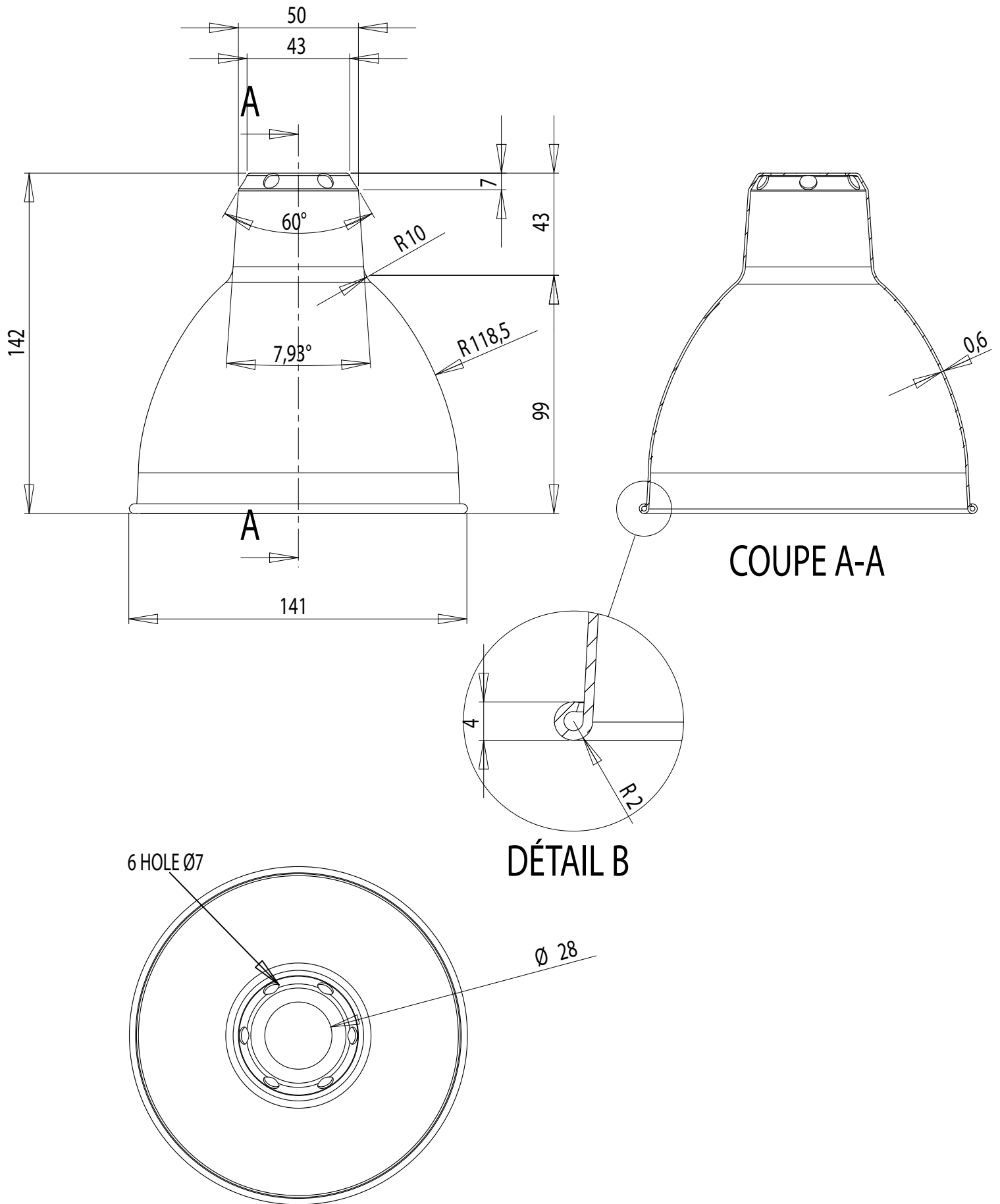

dcw.

Name : **LAMP GRAS**

Materials : PAINTED STEEL/CHROMED STEEL

Part : **ROUND SHADE**

Date :

Rev : 1

Details :