

DÉTAIL F

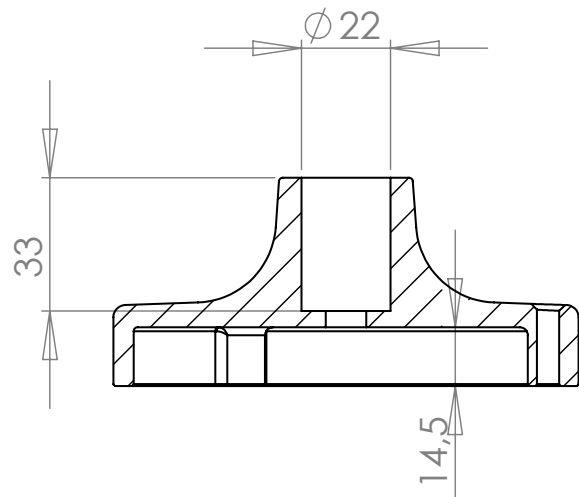

COUPE A-A

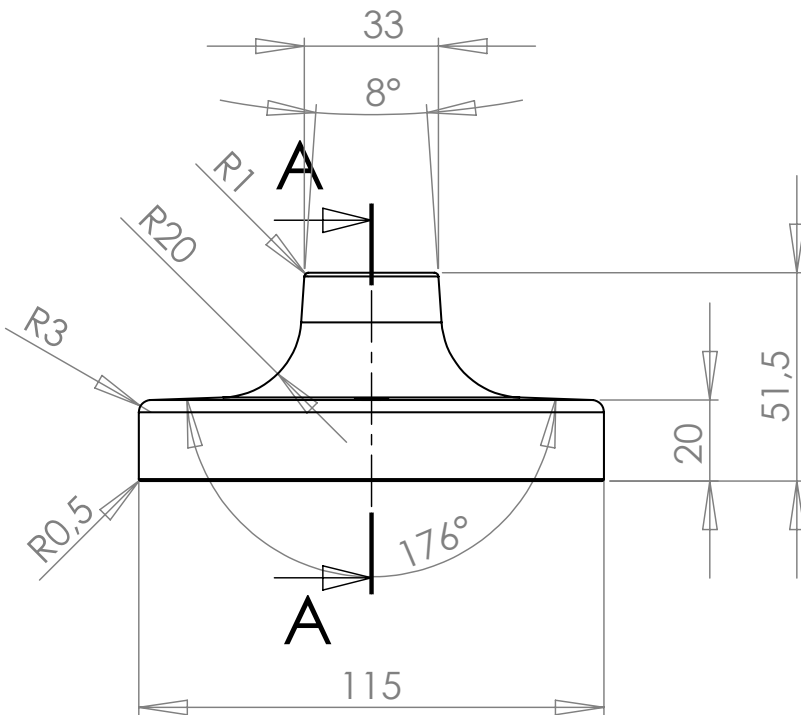
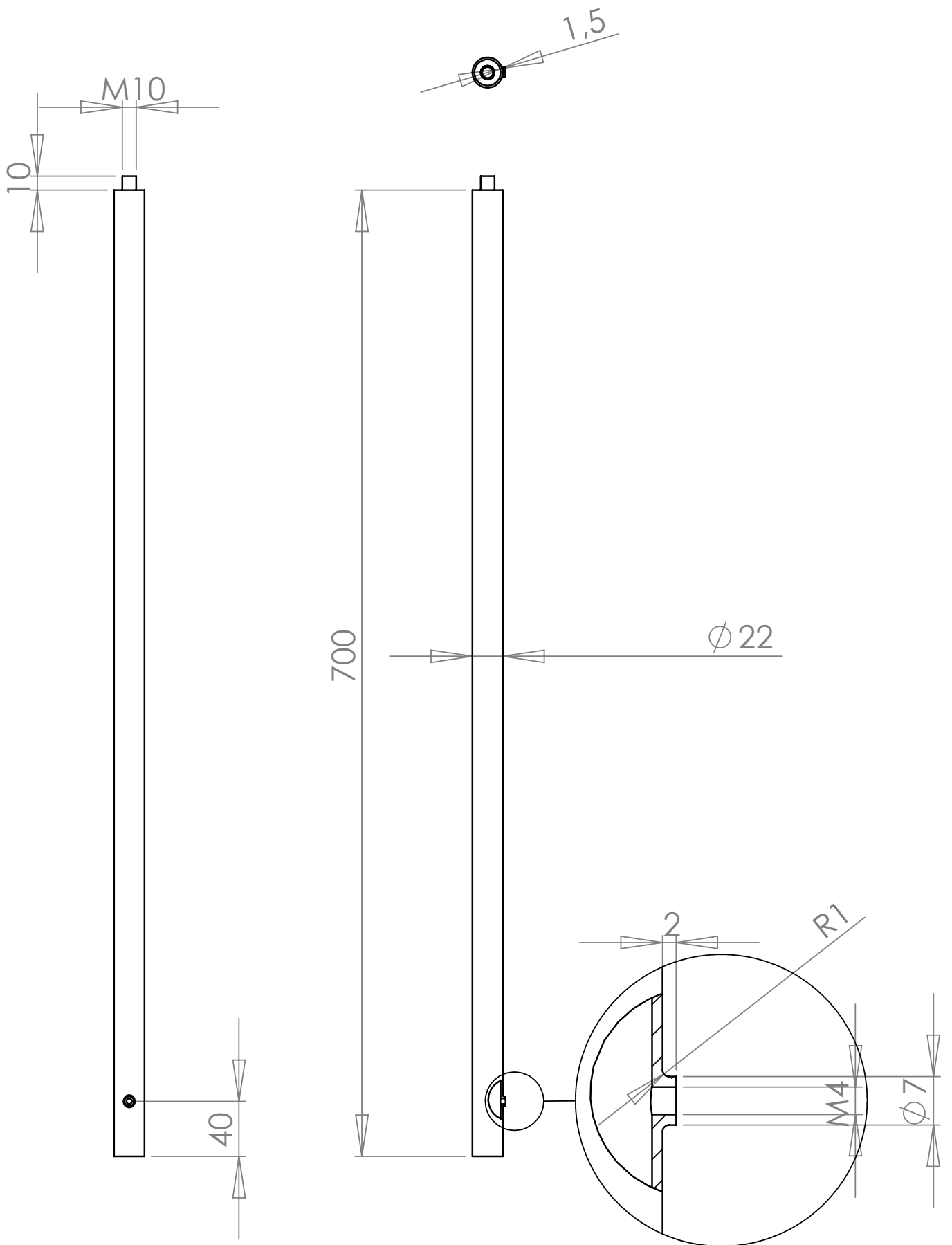

DÉTAIL A

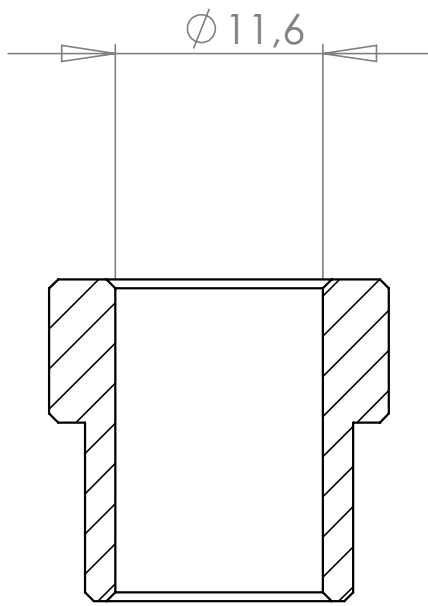

COUPE A-A

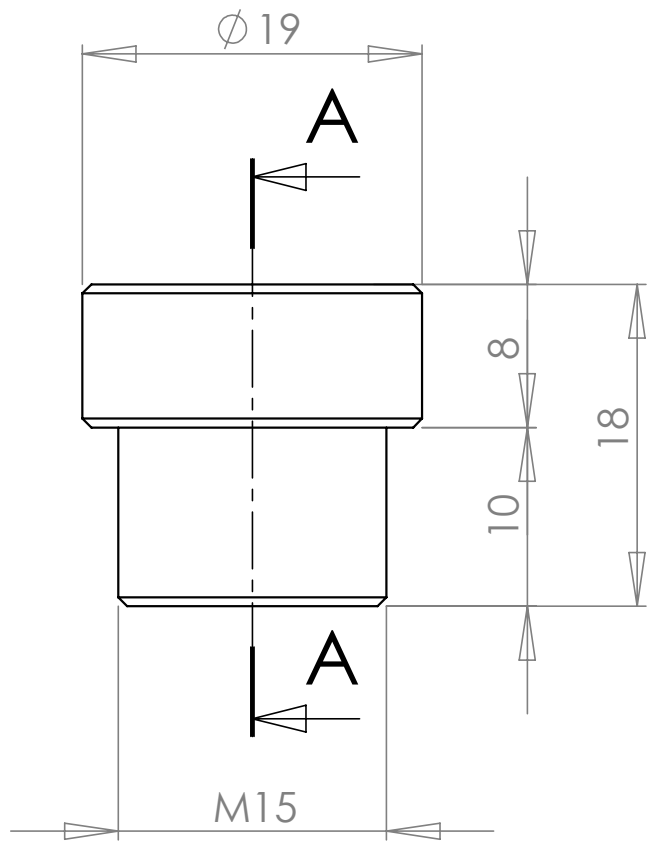

dcw.

Name : LAMP GRAS N°312

Matériaux : NYLON

Part : CENTRING PIECE

Date :

Rev : 1

Details :

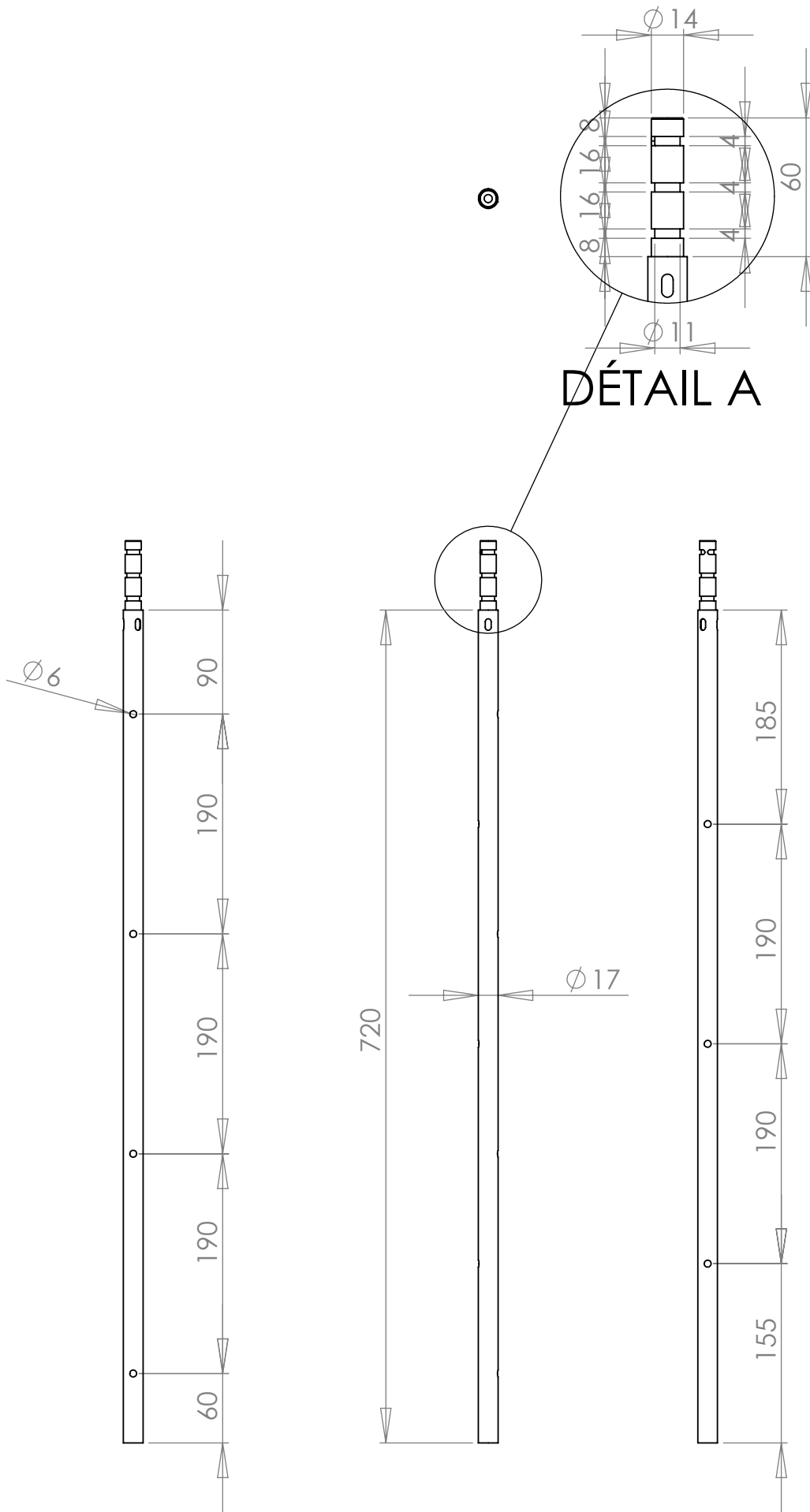

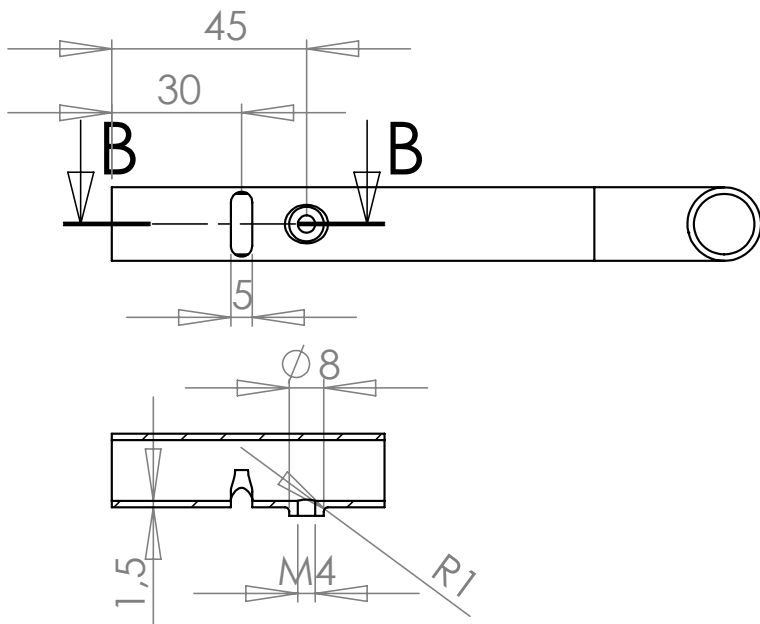

COUPE B-B

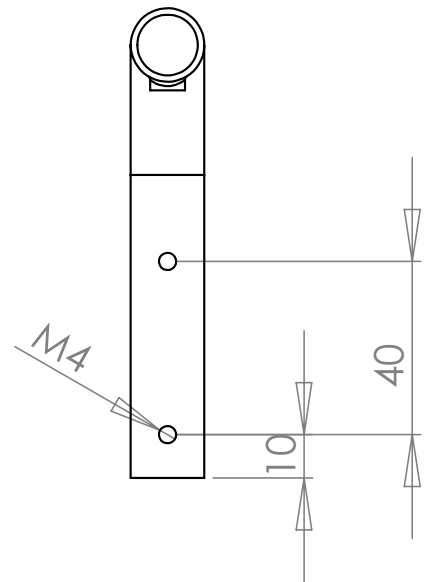
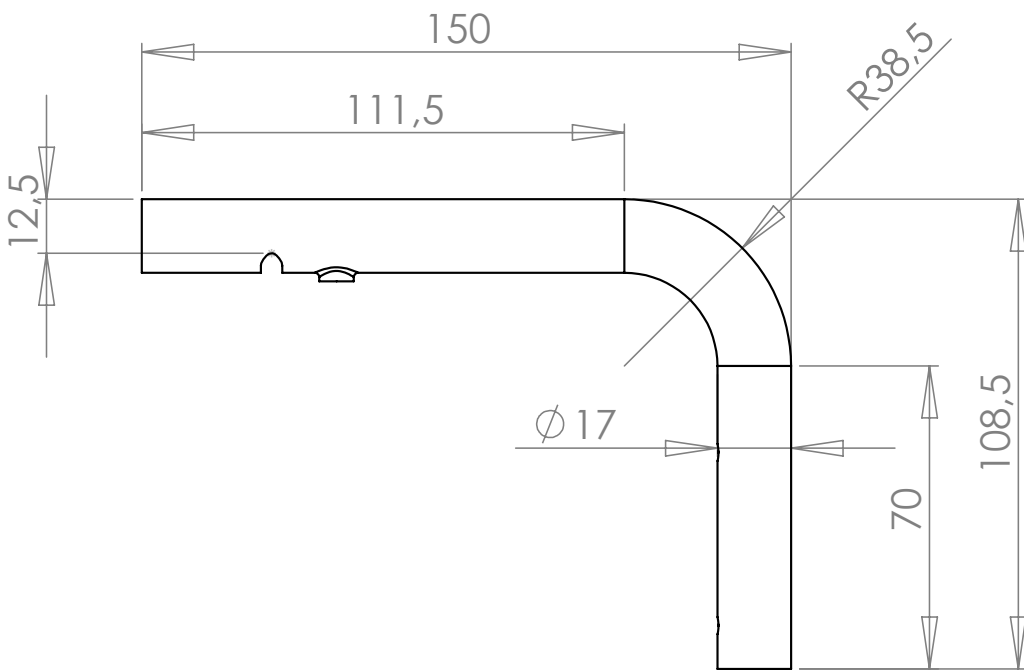

dcw.

Name : LAMP GRAS N°312

Matériaux : PAINTED STEEL/CHROMED STEEL

Part : L TUBE – 150

Date :

Rev : 2

Details :

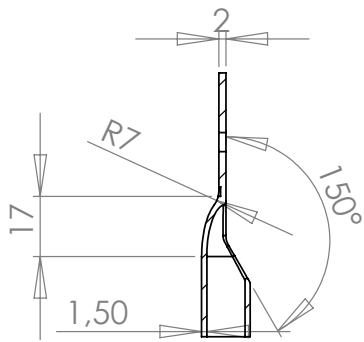

COUPE C-C

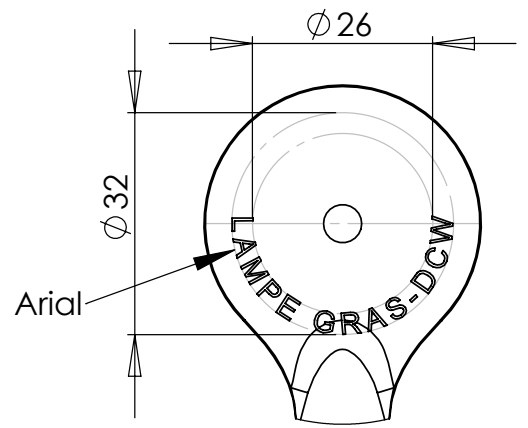

DÉTAIL B

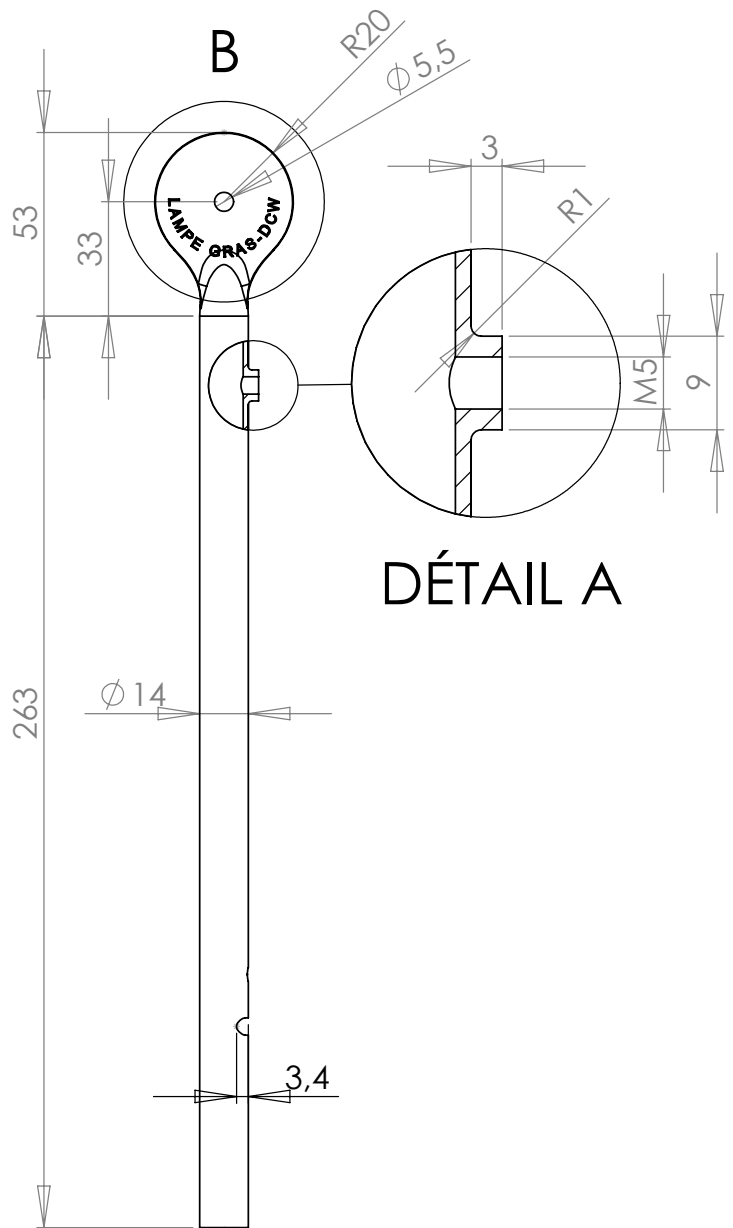
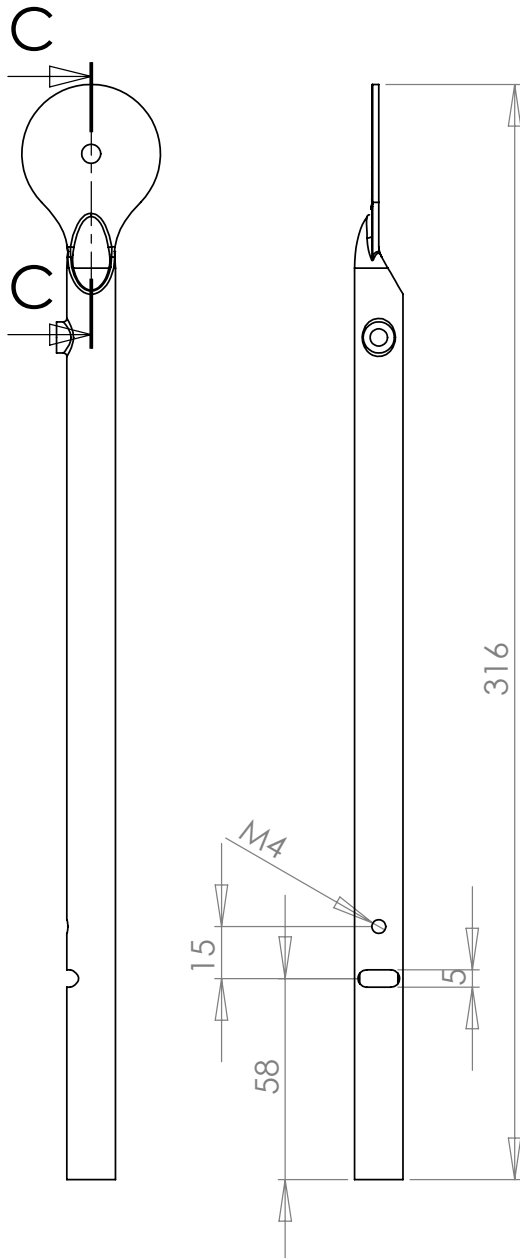

DÉTAIL A

dcw.

Name : LAMP GRAS

Matériaux : PAINTED STEEL/CHROMED STEEL

Part : TUBE 1 – 316

Date :

Rev : 1

Details :

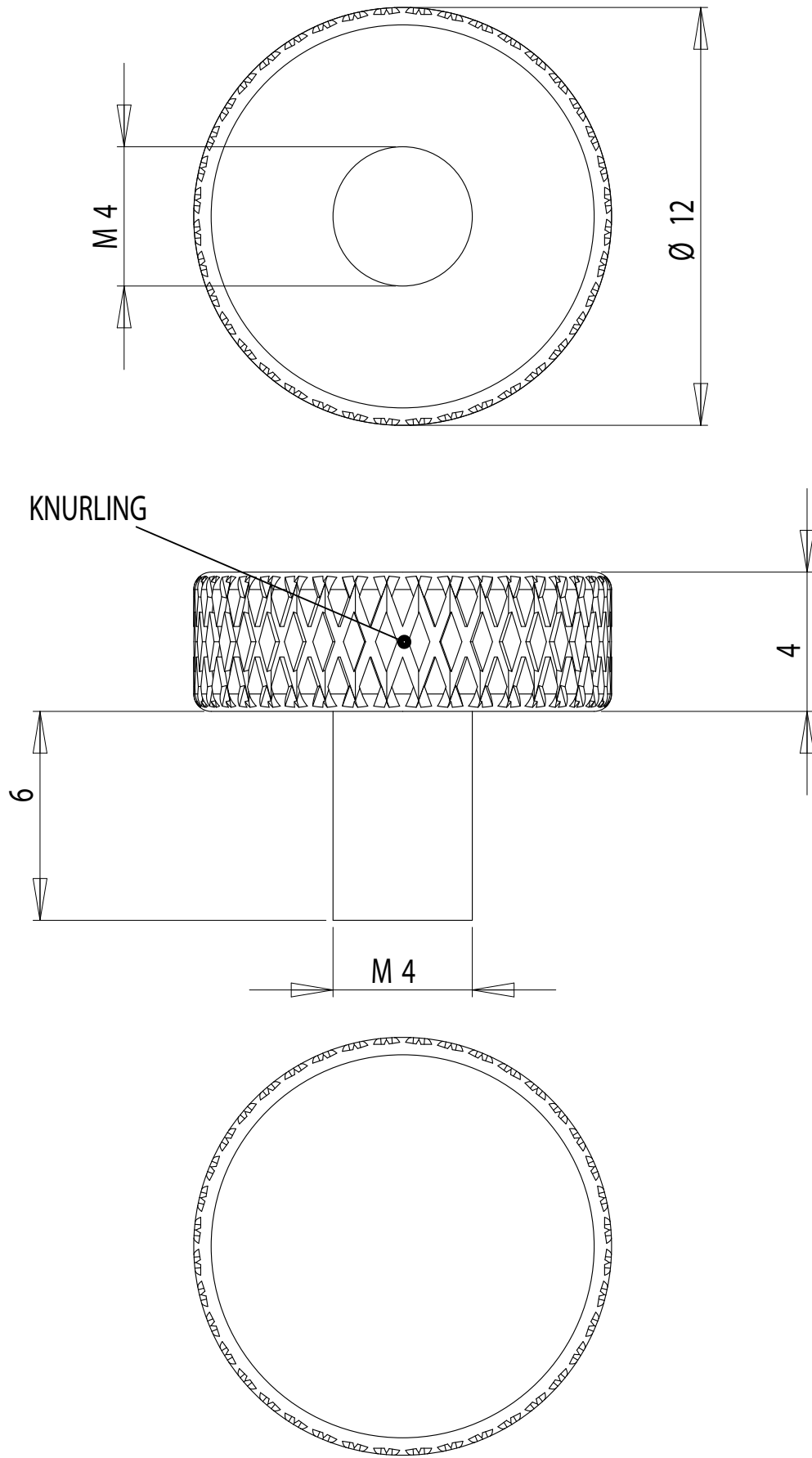

dcw.

Name : **LAMP GRAS**

Materials : PAINTED STEEL

Part : **BREAKING HANDLE**

Date :

Rev : 1

Details :

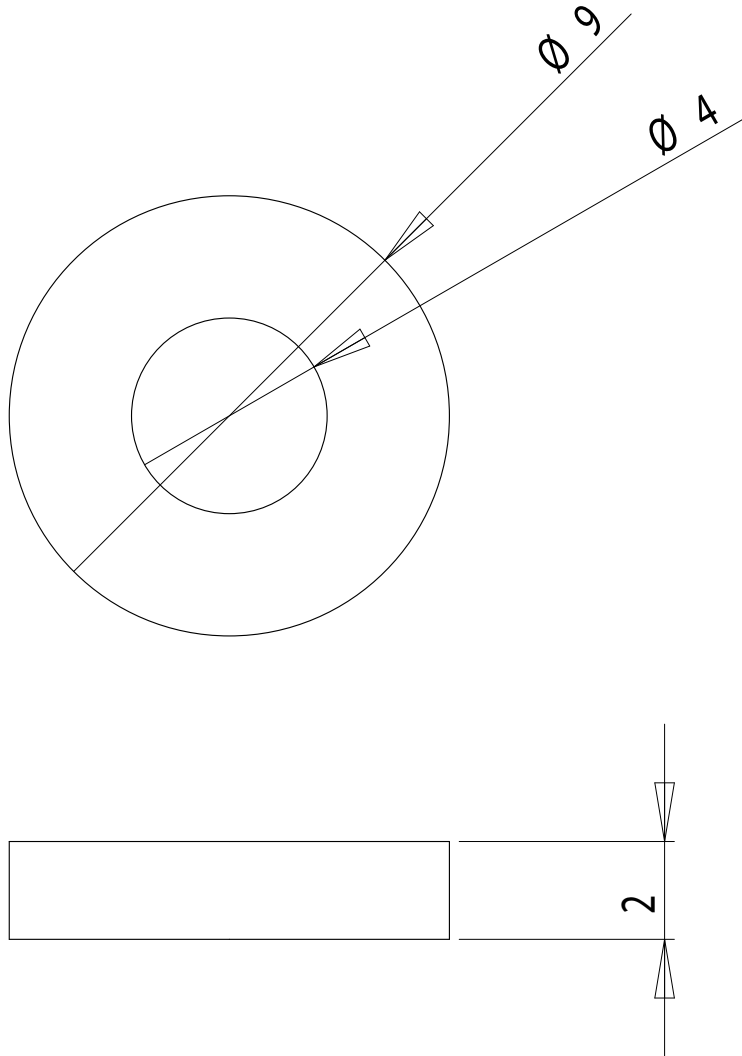

dcw.

Name : **LAMP GRAS**

Materials : PLASTIC

Part : **HANDLE WASHER**

Date :

Rev : 1

Details :

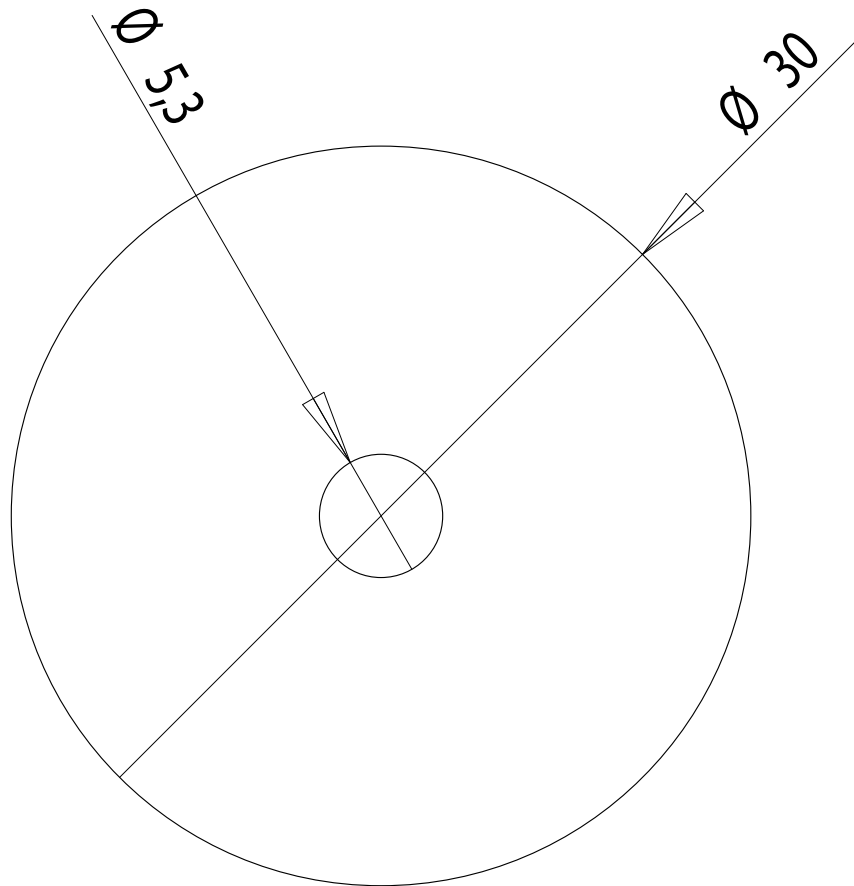
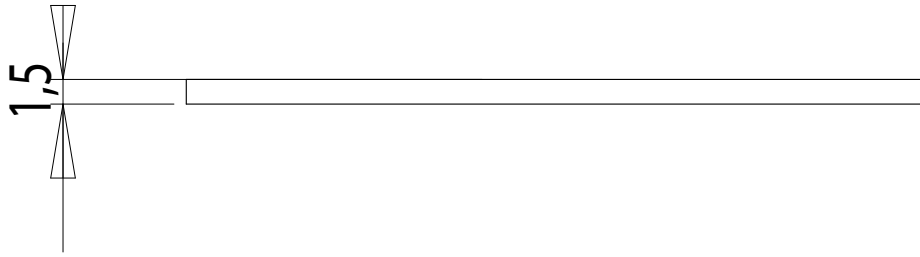

PLIERS SUPPLIED BY DCW

dcw.

Name : LAMP GRAS

Materials : PLASTIC

Part : PLASTIC WASHER – $\varnothing 30$

Date :

Rev : 1

Details :

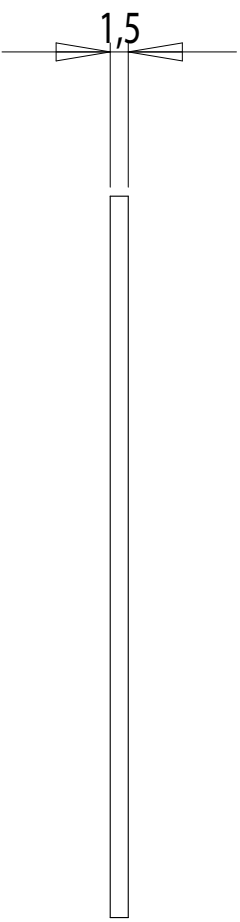
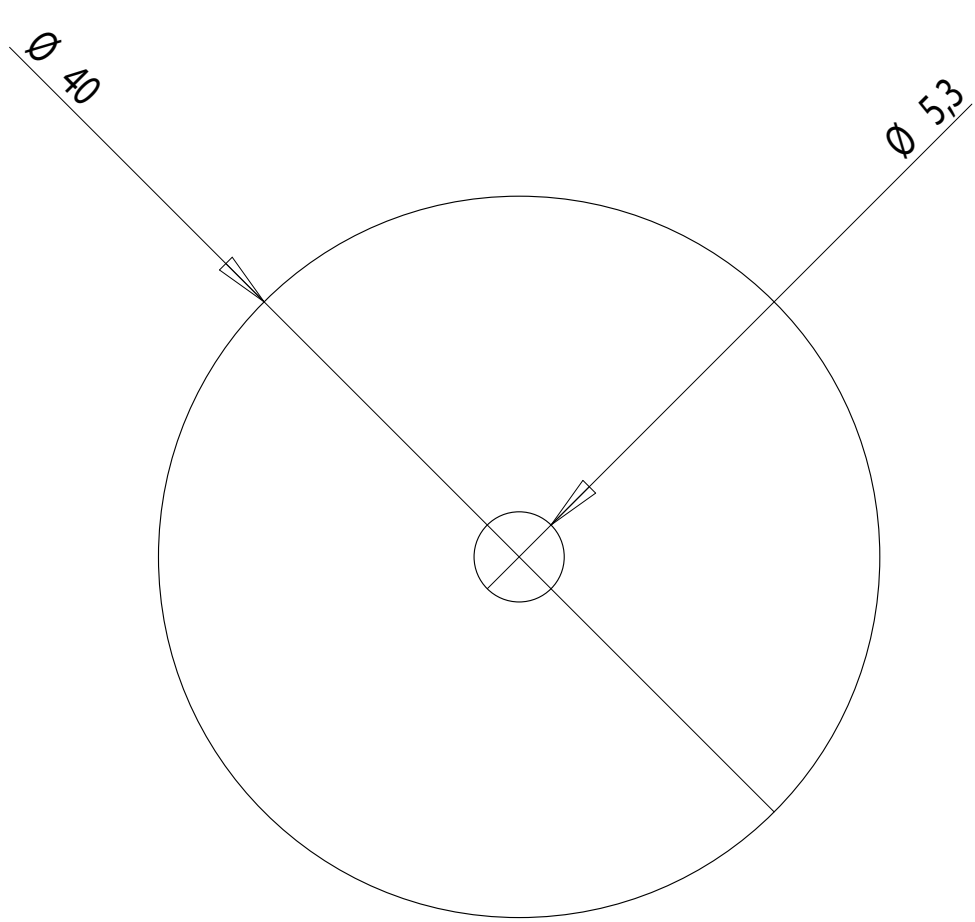

PLIERS SUPPLIED BY DCW

dcw.

Name : LAMP GRAS

Materials : PLASTIC

Part : PLASTIC WASHER – Ø40

Date :

Rev : 1

Details :

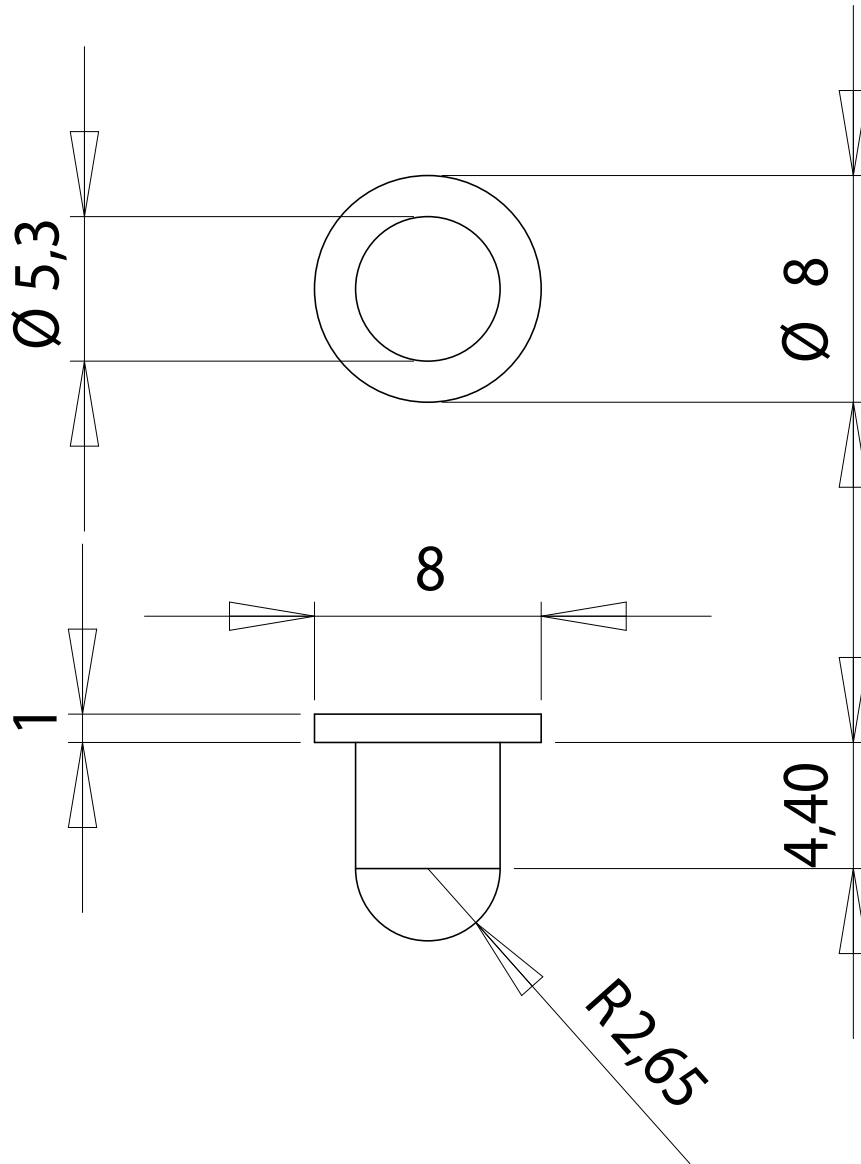

dcw.

Name : **LAMP GRAS**

Materials : CHROMED STEEL

Part : **AXIS**

Date :

Rev : 1

Details :

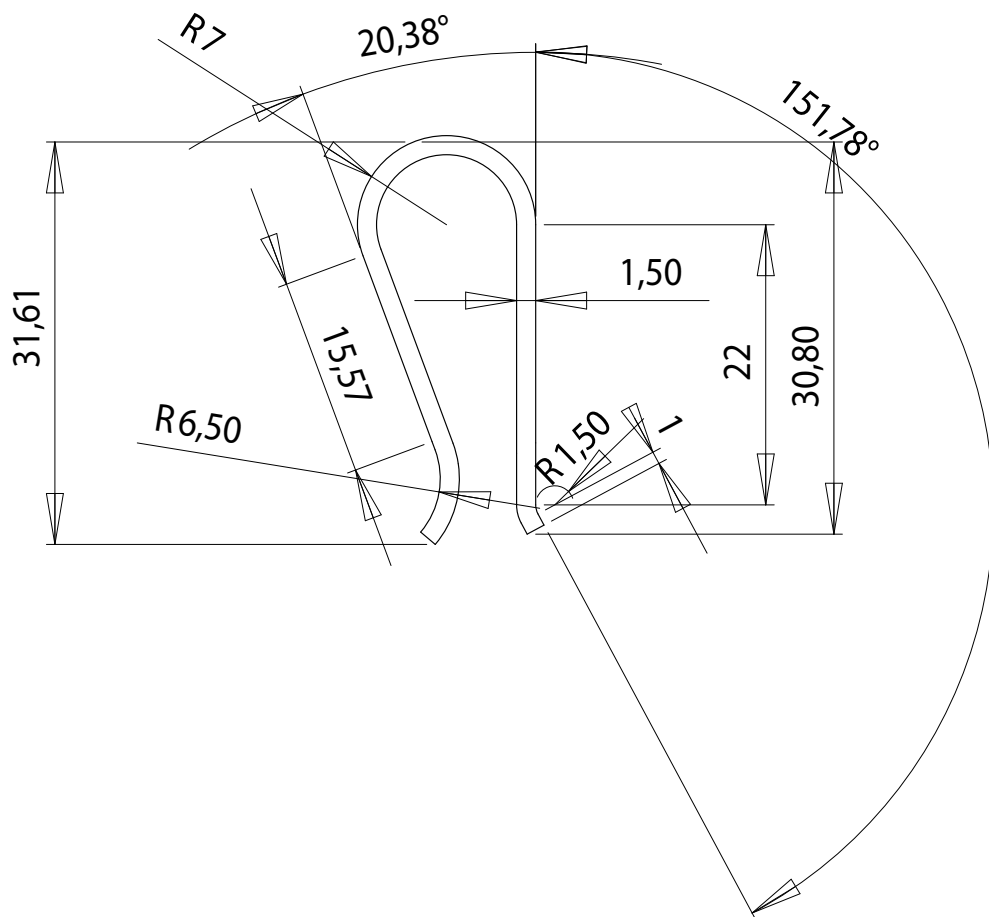
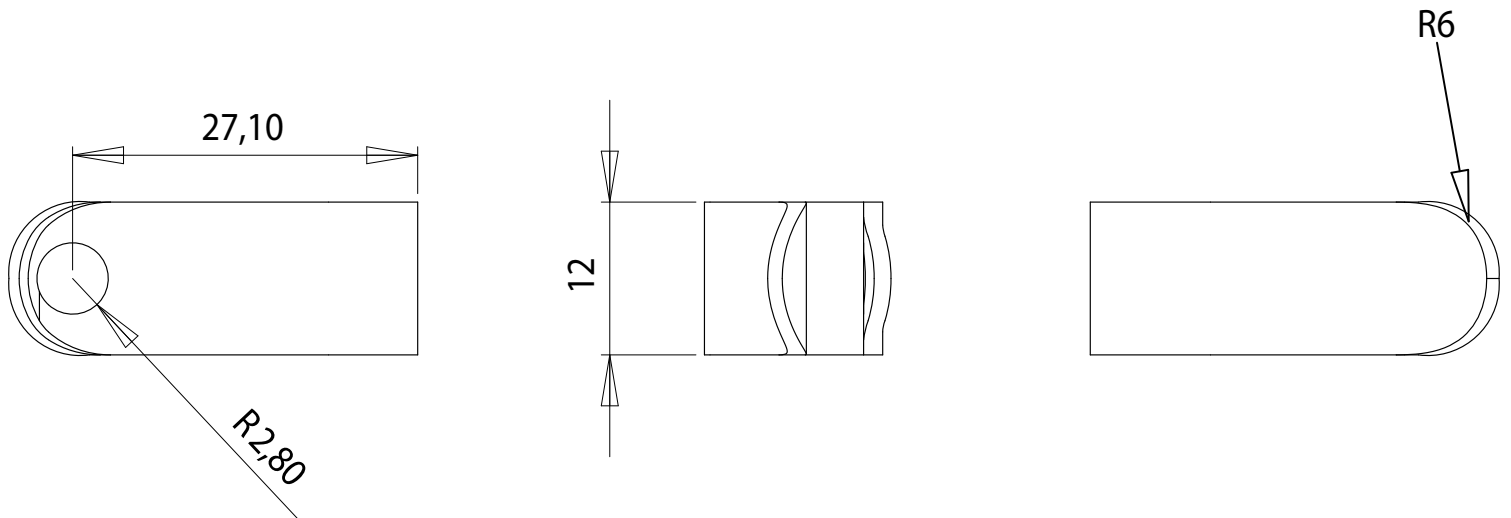

PLIERS SUPPLIED BY DCW

dcw.

Name : LAMP GRAS

Materials : SPRING CHROMED STEEL

Part : PLIERS

Date :

Rev : 1

Details :

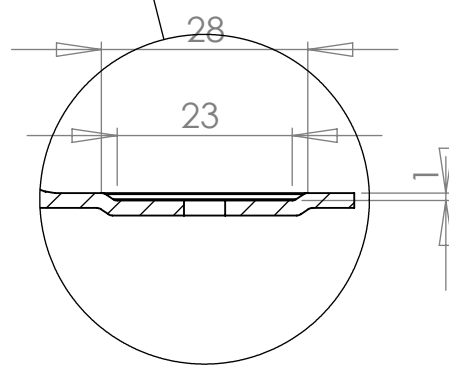
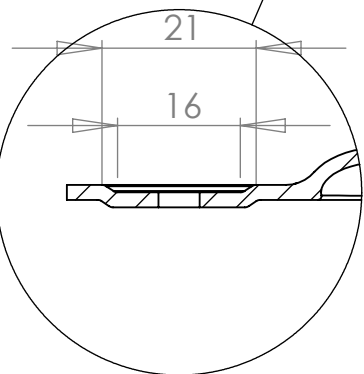
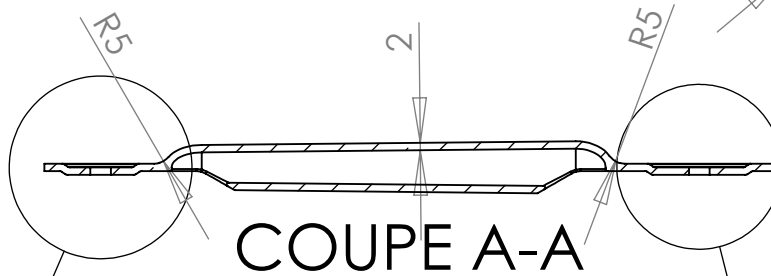
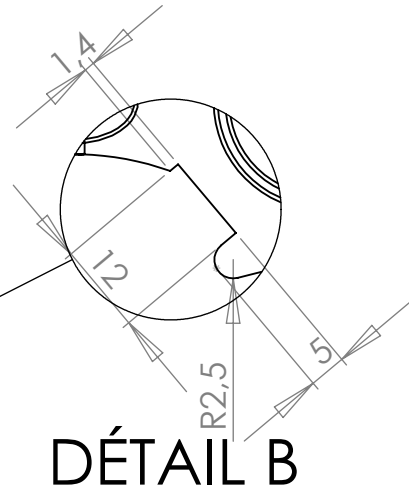
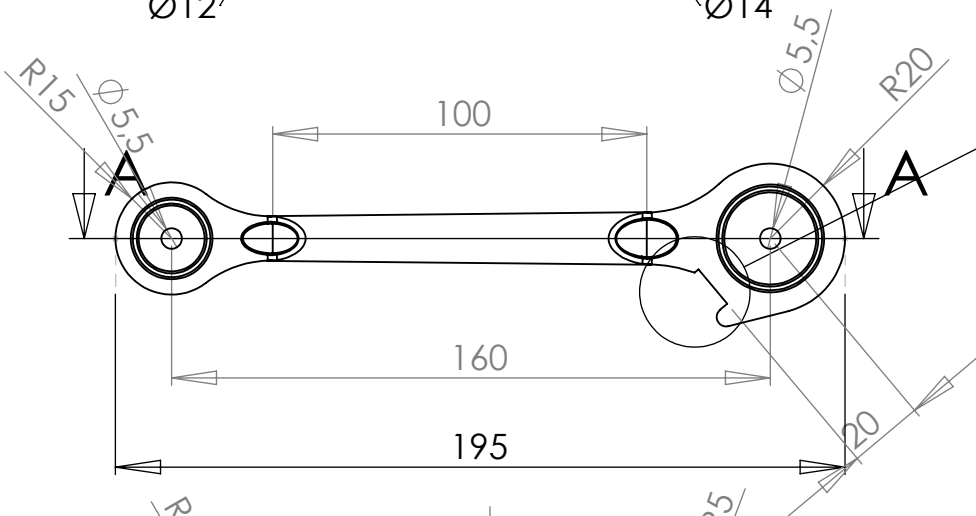
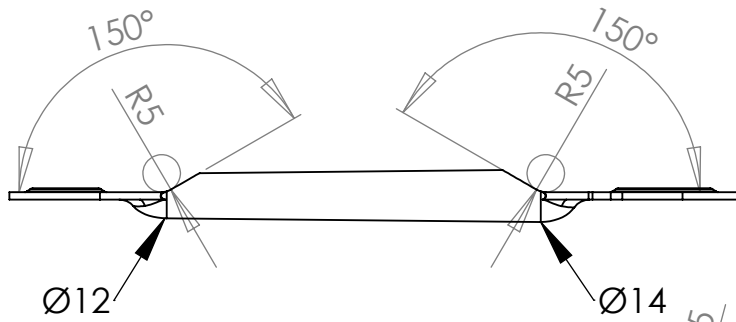
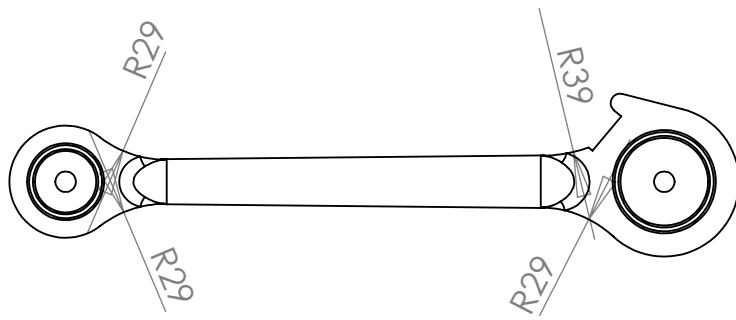

DÉTAIL C

DÉTAIL D

dcw.

Name : LAMP GRAS

Materials : PAINTED STEEL/CHROMED STEEL

Part : TUBE 2

Date : 16/12/2013

Rev : 1

Details :

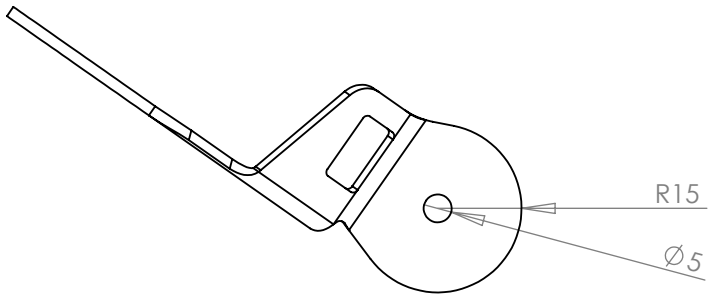
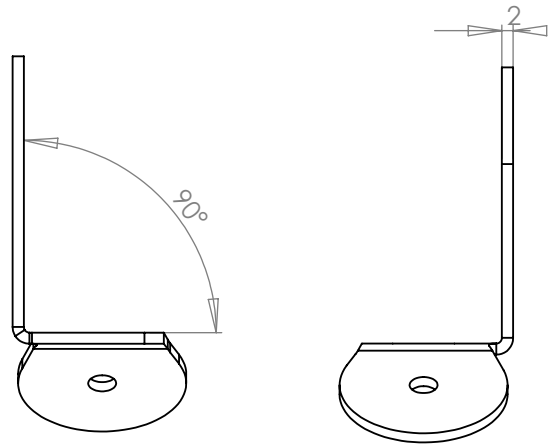
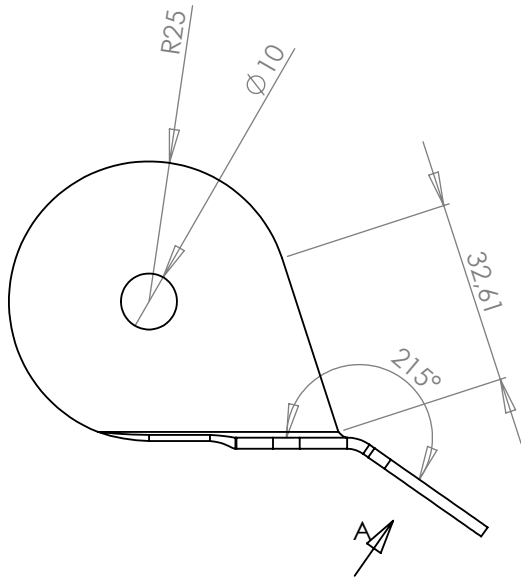
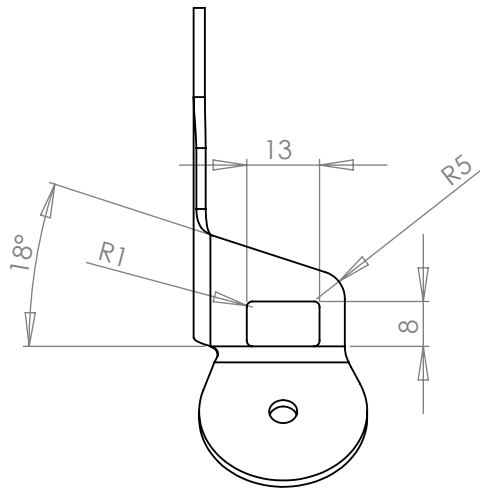

VUE A

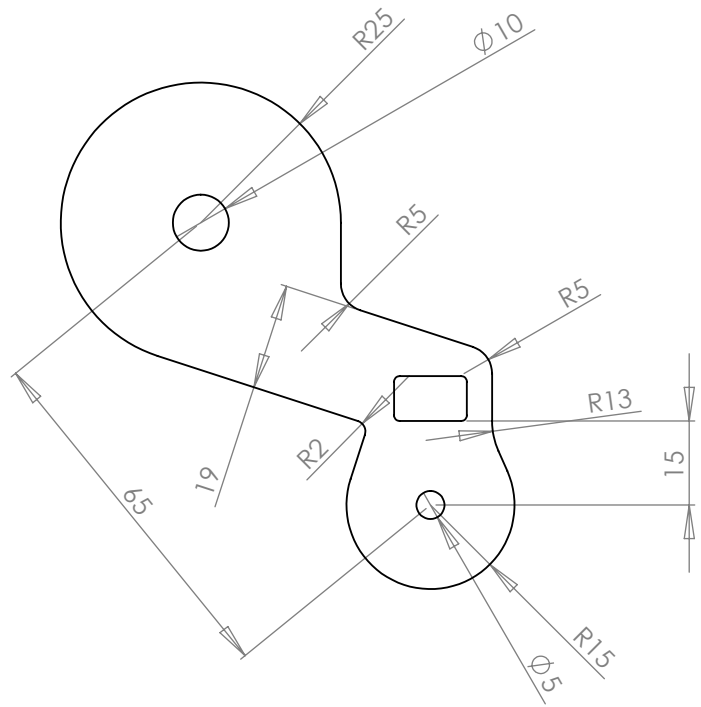

dcw.

Name : **LAMP GRAS**

Materials : PAINTED STEEL / CHROMED STEEL

Part : **JUNCTION PIECE for E27**

Date :

Rev : 1

Details :

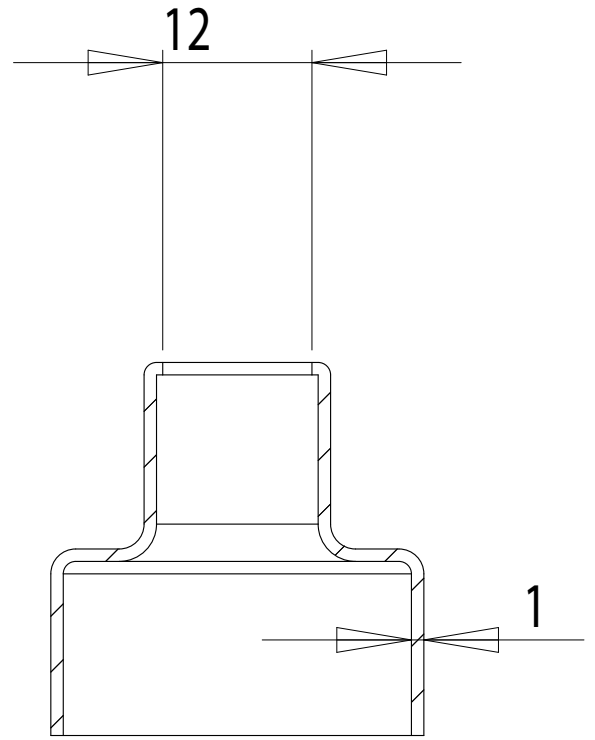
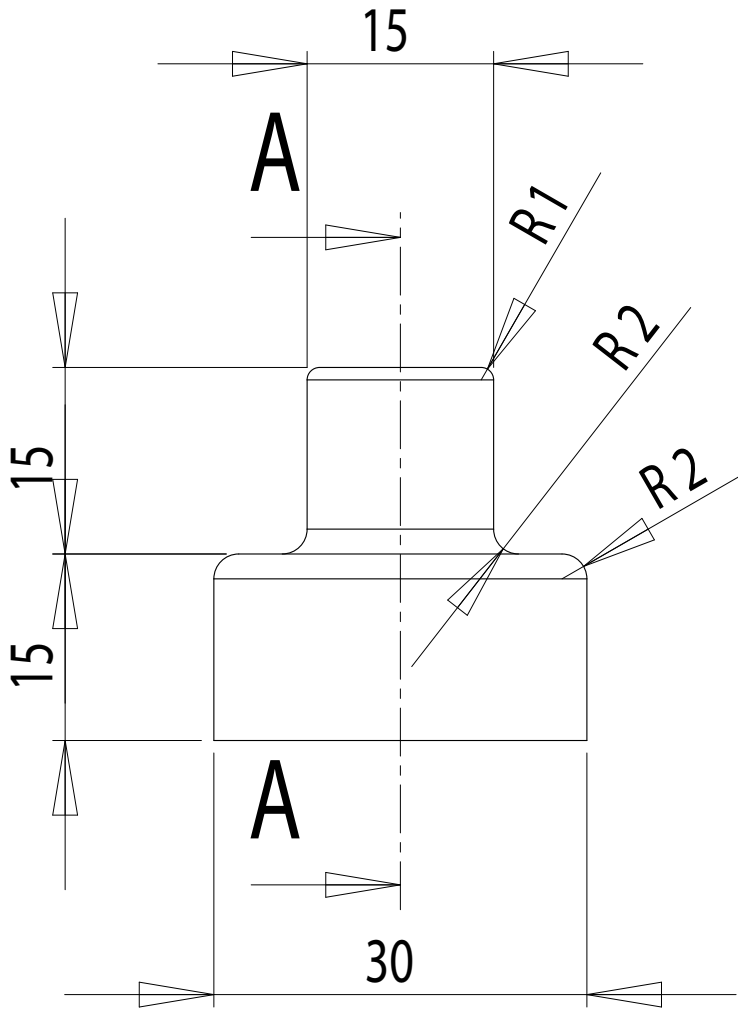

COUPE A-A

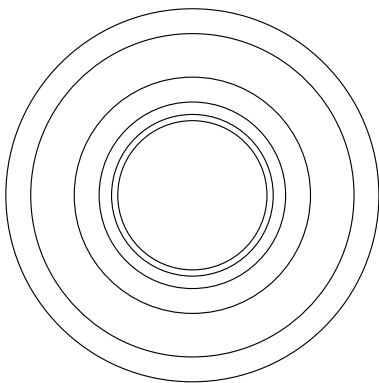

dcw.

Name : **LAMP GRAS**

Materials : PAINTED STEEL / CHROMED STEEL

Part : **COVERING PIECE**

Date :

Rev : 1

Details :

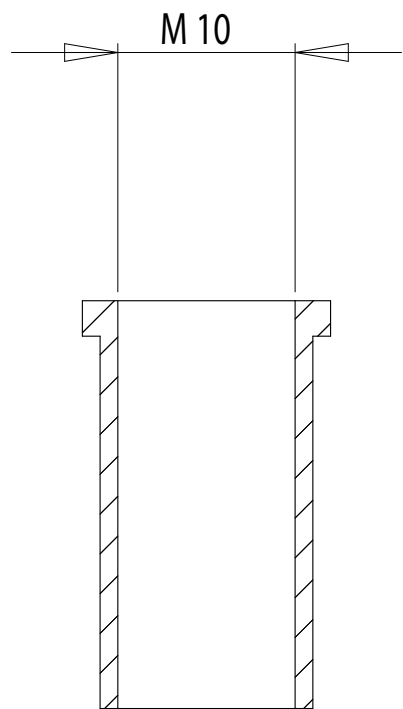
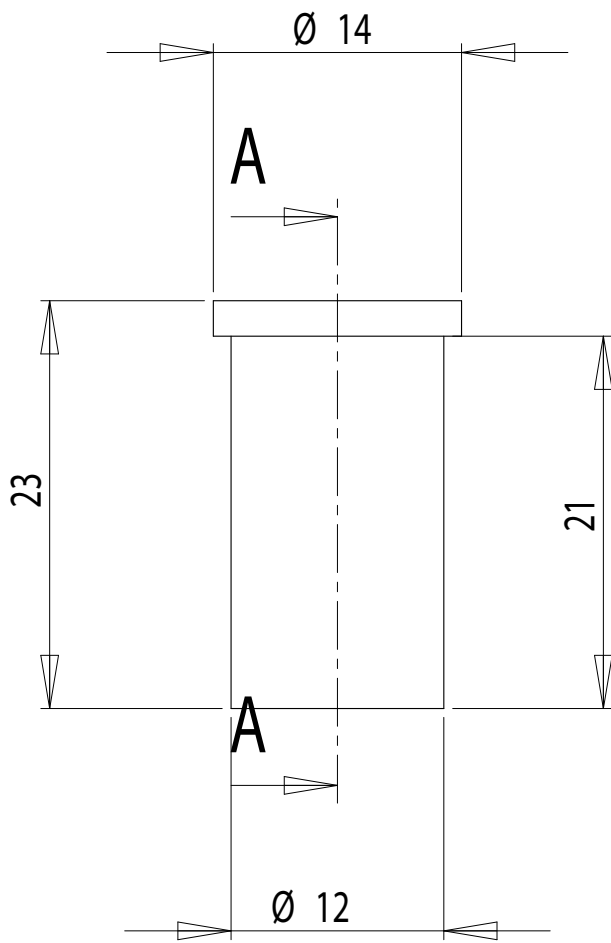

COUPE A-A

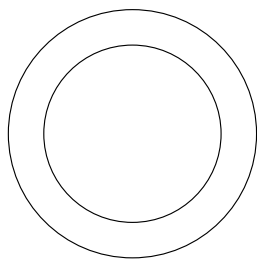

dcw.

Name : **LAMP GRAS**

Part : **FIXATION PIECE**

Date :

Rev : 1

Materials : PAINTED STEEL / CHROMED STEEL

Details :

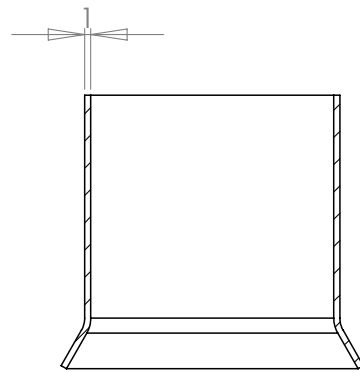
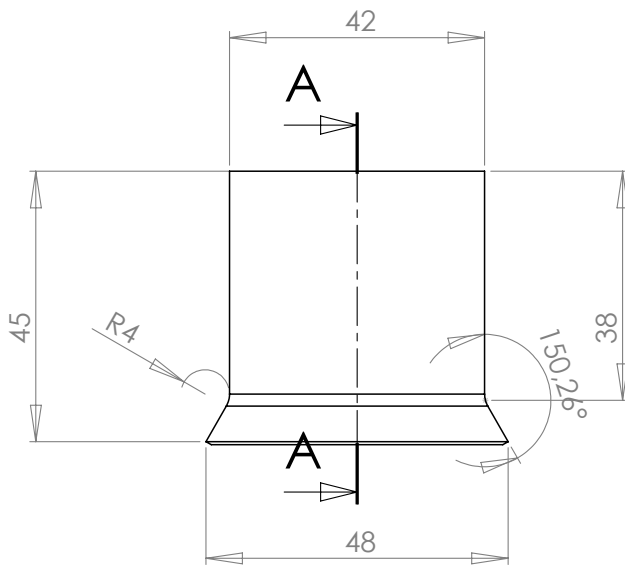
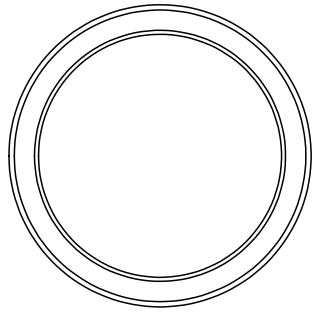

COUPE A-A

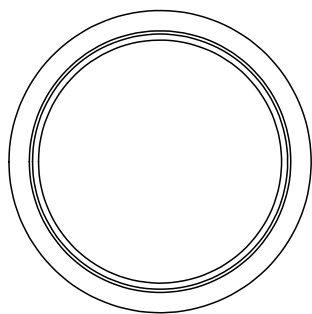

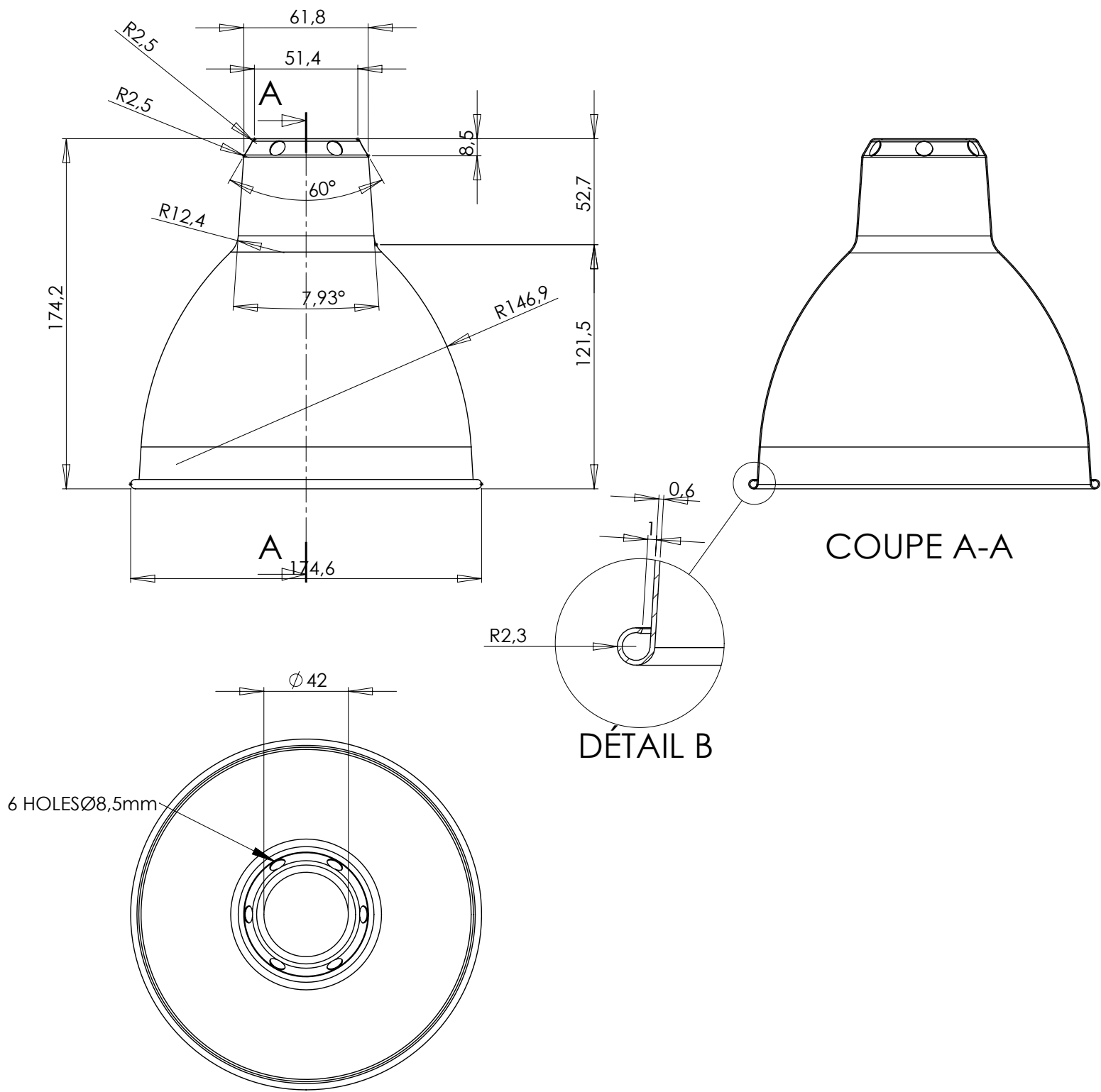

RANGE : LAMPE GRAS	REF :	MATERIAL/FINISHING : PAINTED STEEL - WHITE INSIDE
PART : SHADE ROUND LARGE		
REV N° : 2		