

Qty	Piece	Finishing			
1	COVER	BLACK SATIN	1	COVERING PIECE	BLACK SATIN
1	WEIGHT	BLACK SATIN	1	FIXATION PIECE	BLACK SATIN
1	BASE	BLACK SATIN	1	ROUND SHADE	BLACK OUTSIDE / WHITE INSIDE
1	VERTICAL TUBE	BLACK SATIN	1	BULBHOLDER SPACER	CHROME
1	S TUBE	BLACK SATIN	1	BULBHOLDER SCREW	CHROME
1	L TUBE	BLACK SATIN	1	BULBHOLDER	
1	HANDLE	BLACK SATIN	3	M3 x 4 SCREW	BLACK
1	HANDLE WASHER	BLACK	3	M10 x 4 NUT	BLACK
1	TUBE 1	BLACK SATIN	1	M4 x 5 SCREW	BLACK
1	PLASTIC WASHER Ø40	RED	1	M5 x 10 PLASTIC SCREW	BLACK
1	PLASTIC WAHSER Ø30	RED	2	M4 x 3 SCREW	BLACK
2	PLIERS	BLACK SATIN	3	M6 x 7 SCREW	BLACK
1	TUBE 2	BLACK SATIN	1	THREAD 10X100	
1	JUNCTION PIECE	BLACK SATIN			

dcw.

Name : LAMP GRAS N°411 BL-SAT

Matérials :

Part :

Date : 17/01/2013

Rev : 1

Details : E14 - 11w ; Ardití metal bulbholder ; Dimmer on wire - Black fabric wire

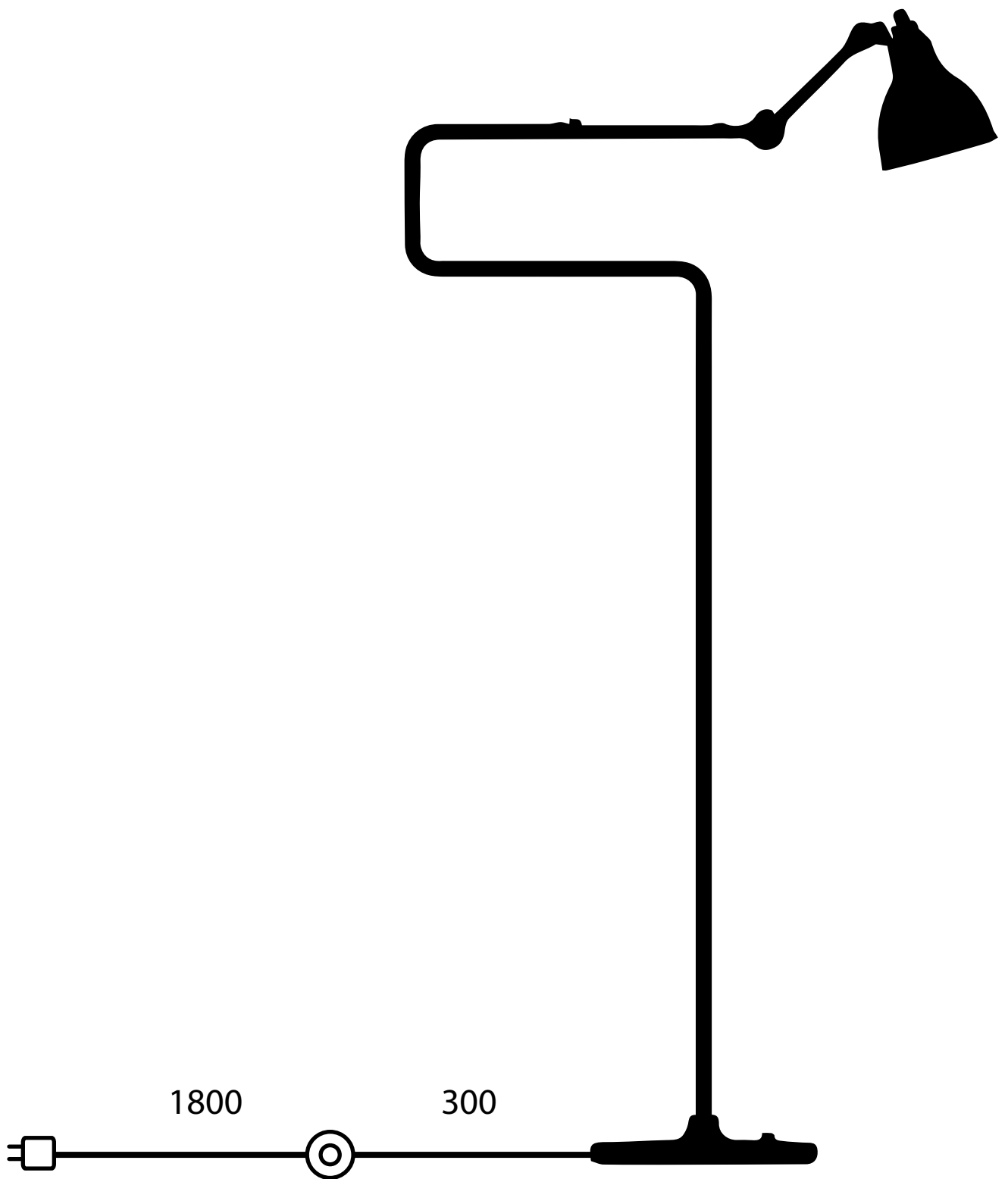

dcw.

Name : LAMP GRAS N°411

Matériaux :

Part : ELEC LENGHT NO DIMMER

Date : 17/01/2013

Rev : 1

Details :

325

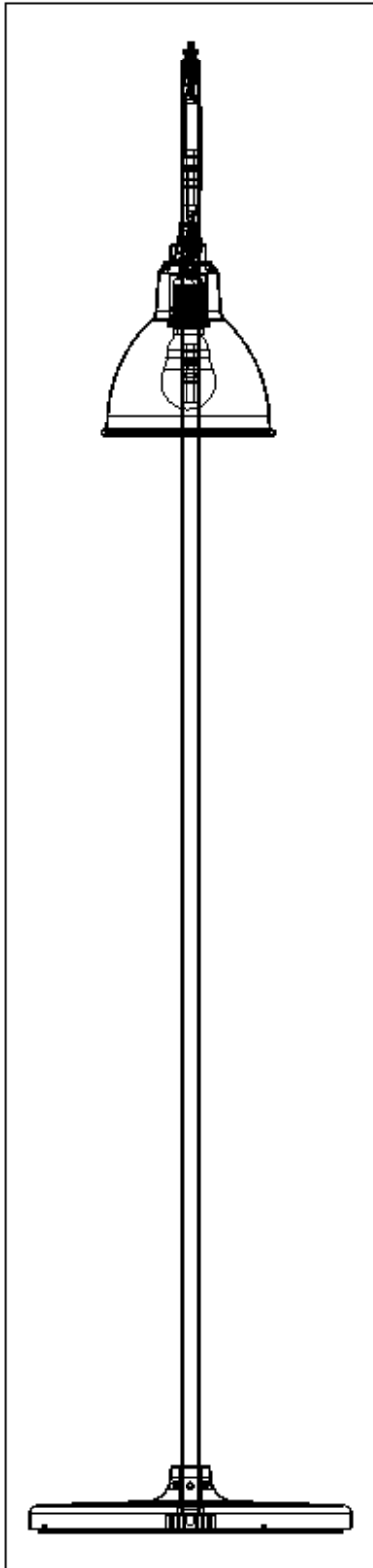

585

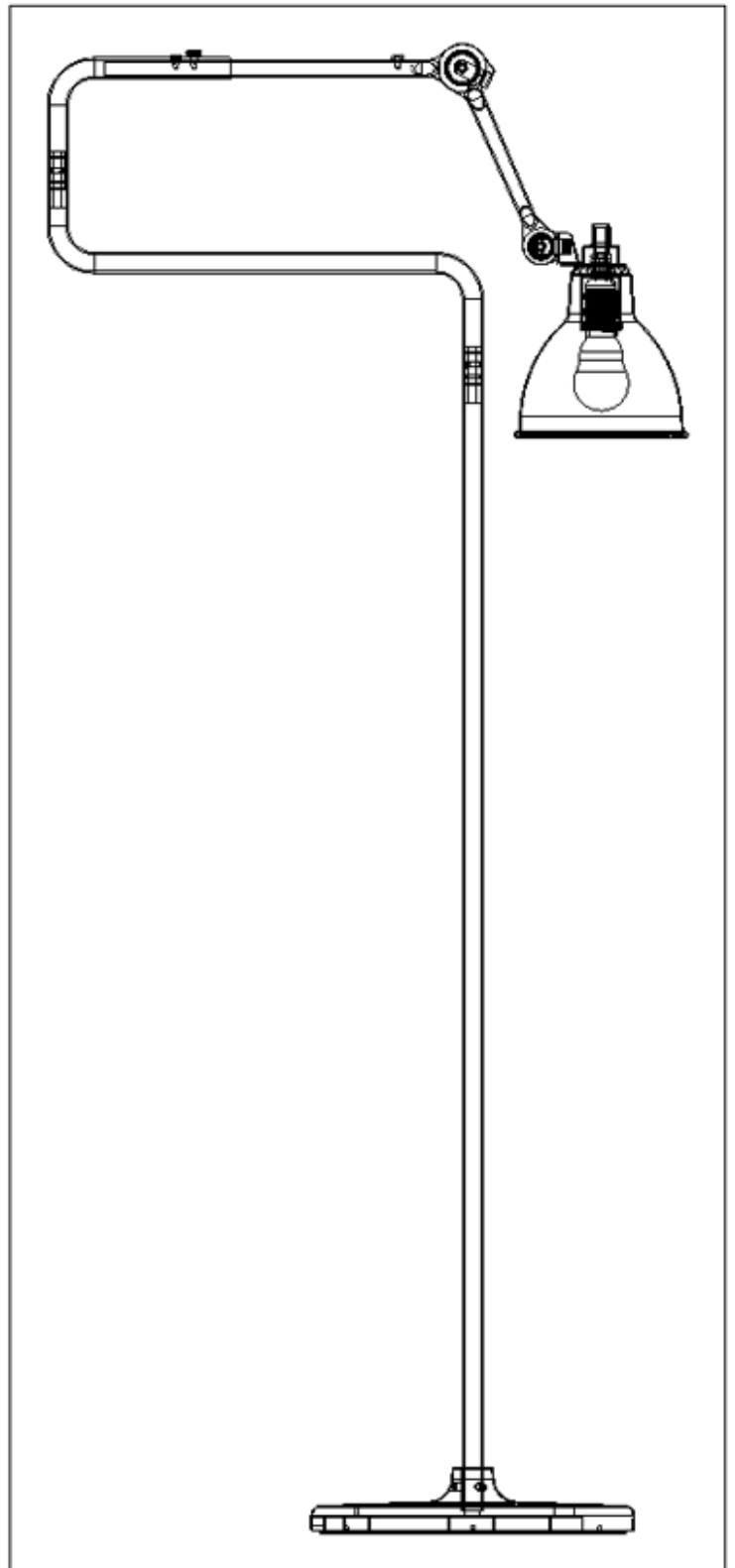

1285

dcw.

Name : LAMP GRAS

Part : N°411 PACKAGE

Date :

Rev : 1

Matérials :

Details :

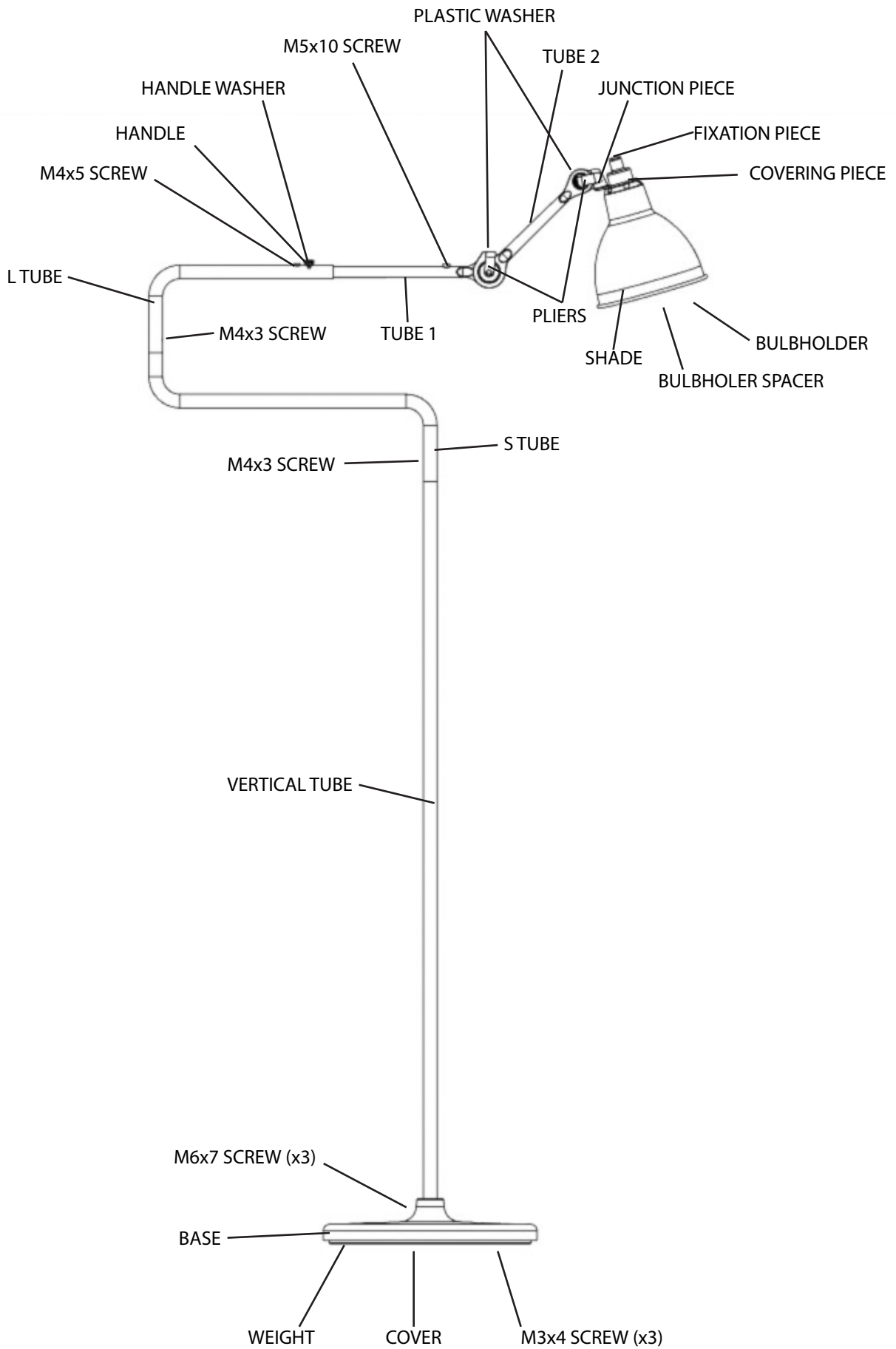

dcw.

Name : LAMP GRAS N°411

Materials :

Part : ELEMENTS

Date : 17/01/2013

Rev : 1

Details :

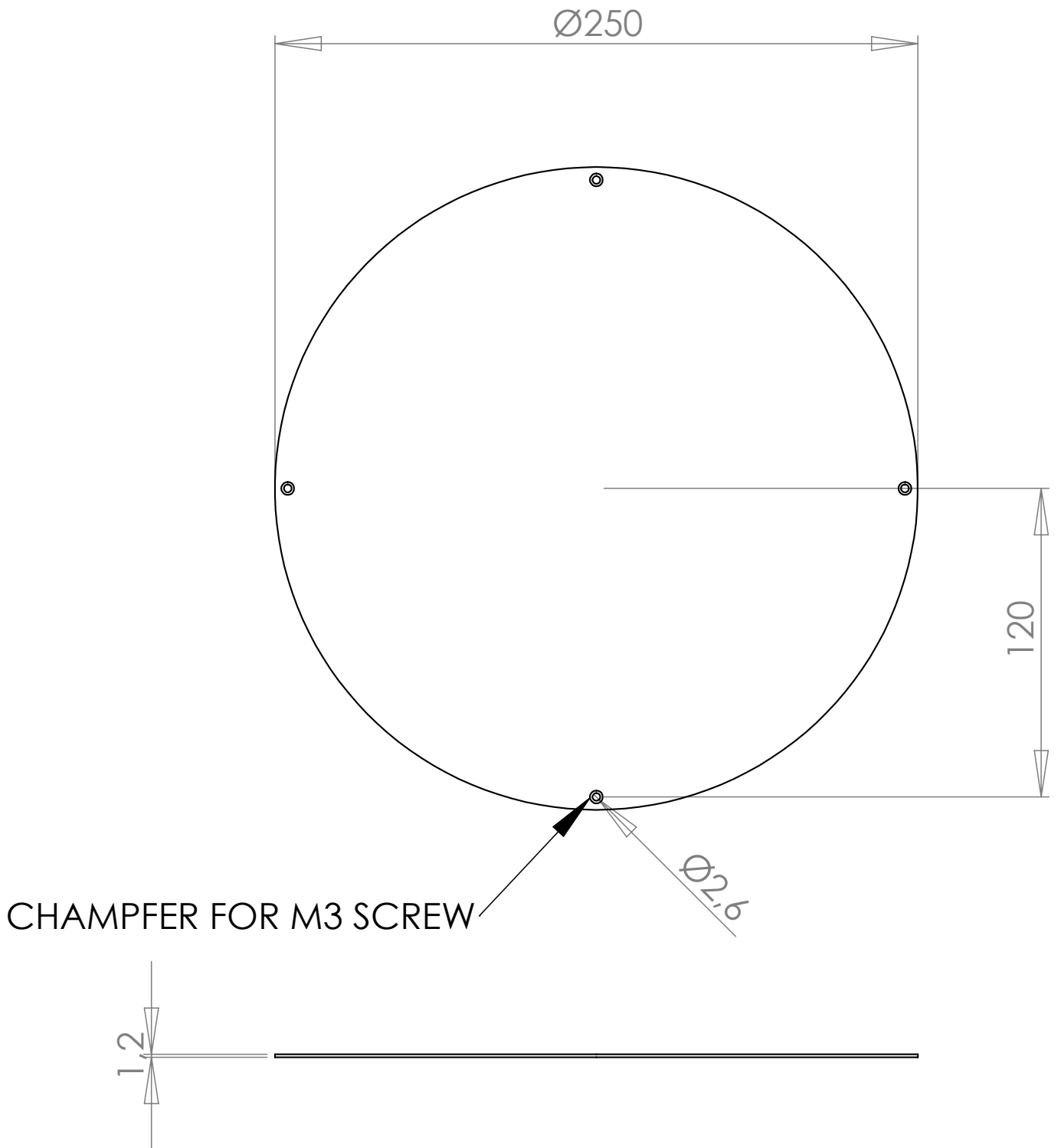

dcw.

Name : LAMP GRAS N°411

Materials : PAINTED STEEL

Part : COVER

Date :

Rev : 2

Details :

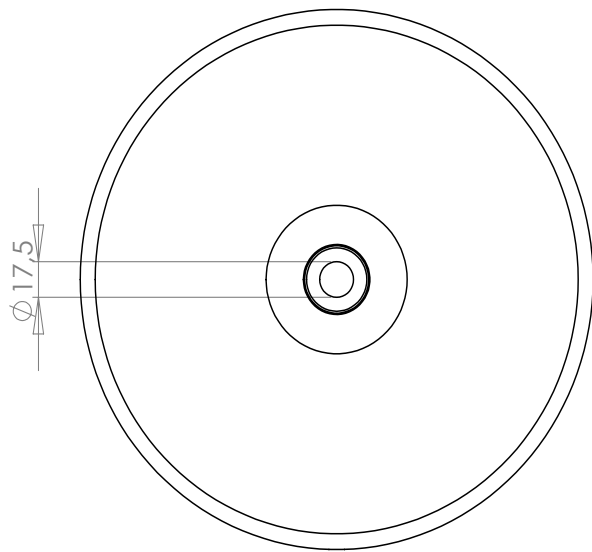
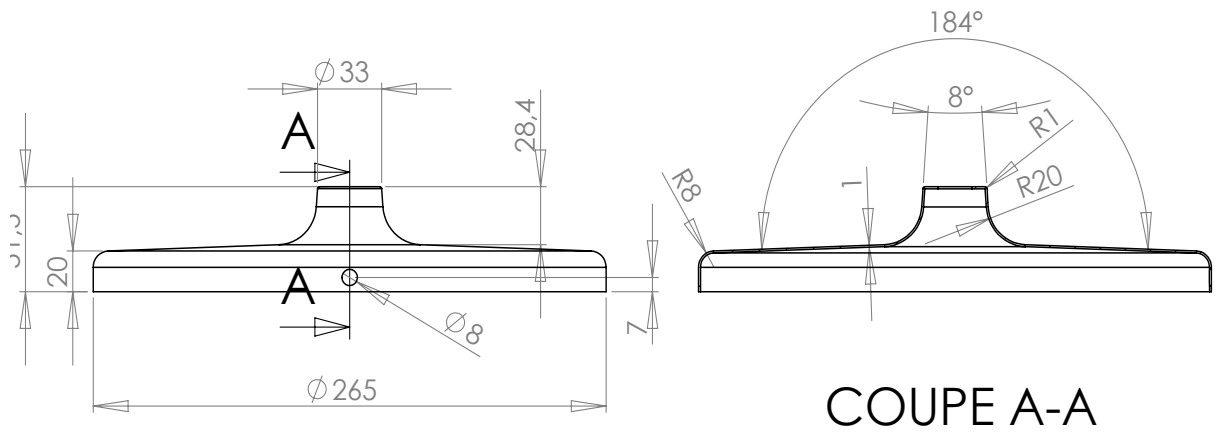

dcw.

Name : LAMP GRAS N°411

Materials : PAINTED STEEL

Part : BASE NO DIMMER

Date : 17/01/2013

Rev : 1

Details :

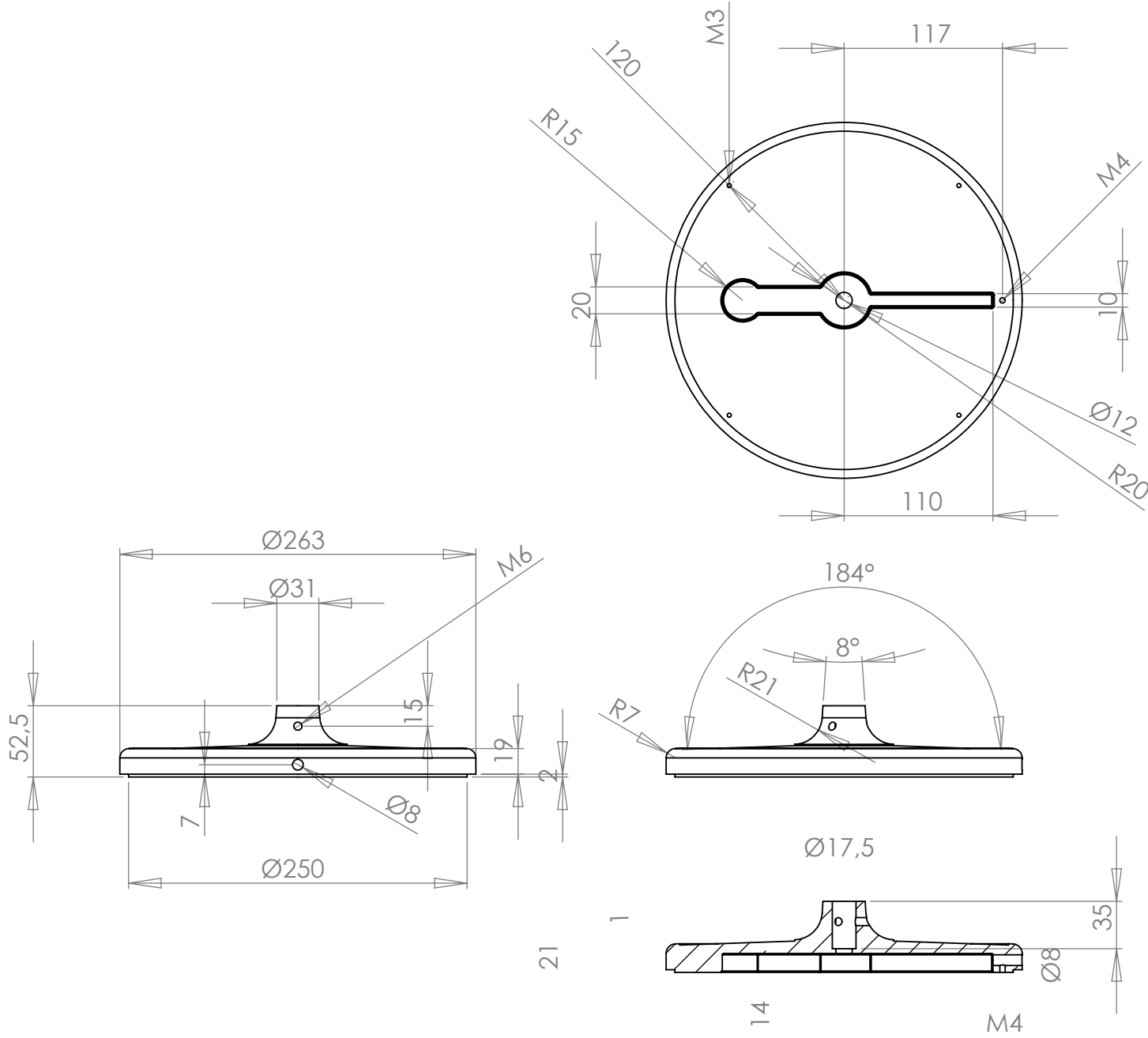

COUPE A-A

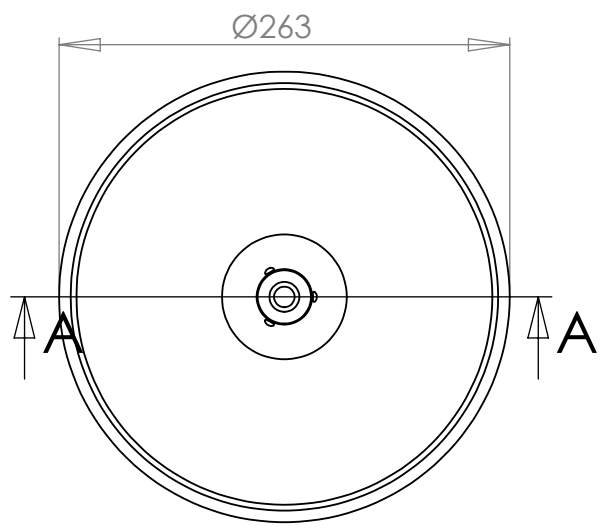

dcw.

Name : LAMP GRAS N°411		Materials : PAINTED STEEL CAST
Part : WEIGHT NO DIMMER		
Date :	Rev : 2	Details :

CHAMPFER
FOR M3 SCREW

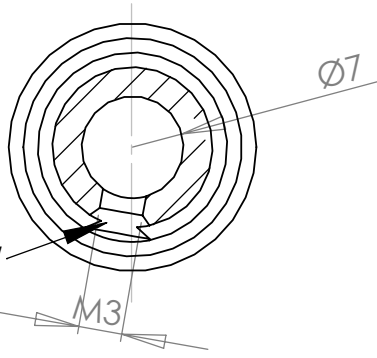

COUPE D-D

D D



925

Ø17



TORIC JOINTS

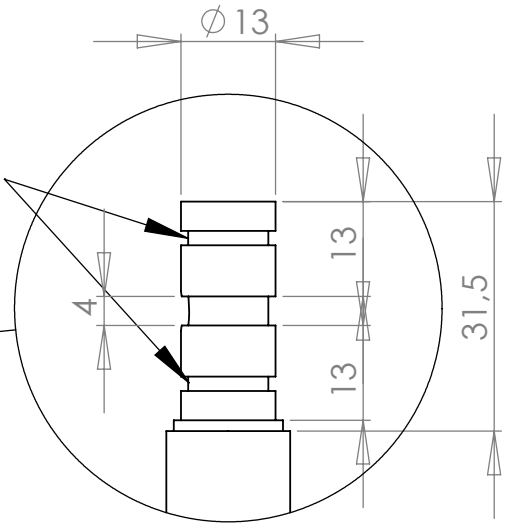

DÉTAIL C

1,5

dcw.

Name : LAMP GRAS N°411

Matériaux : PAINTED STEEL

Part : VERTICAL TUBE

Date : 17/01/2013

Rev : 1

Details :

Name : LAMP GRAS
Part : S TUBE
Date : 17/01/2013

Rev : 1

Materials : PAINTED STEEL/CHROMED STEEL
Details :

dcw.

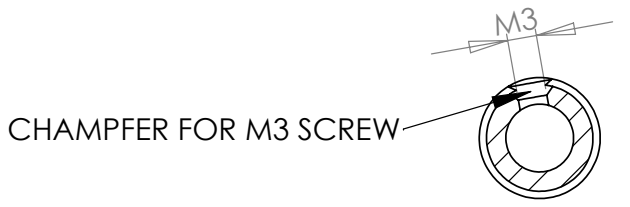
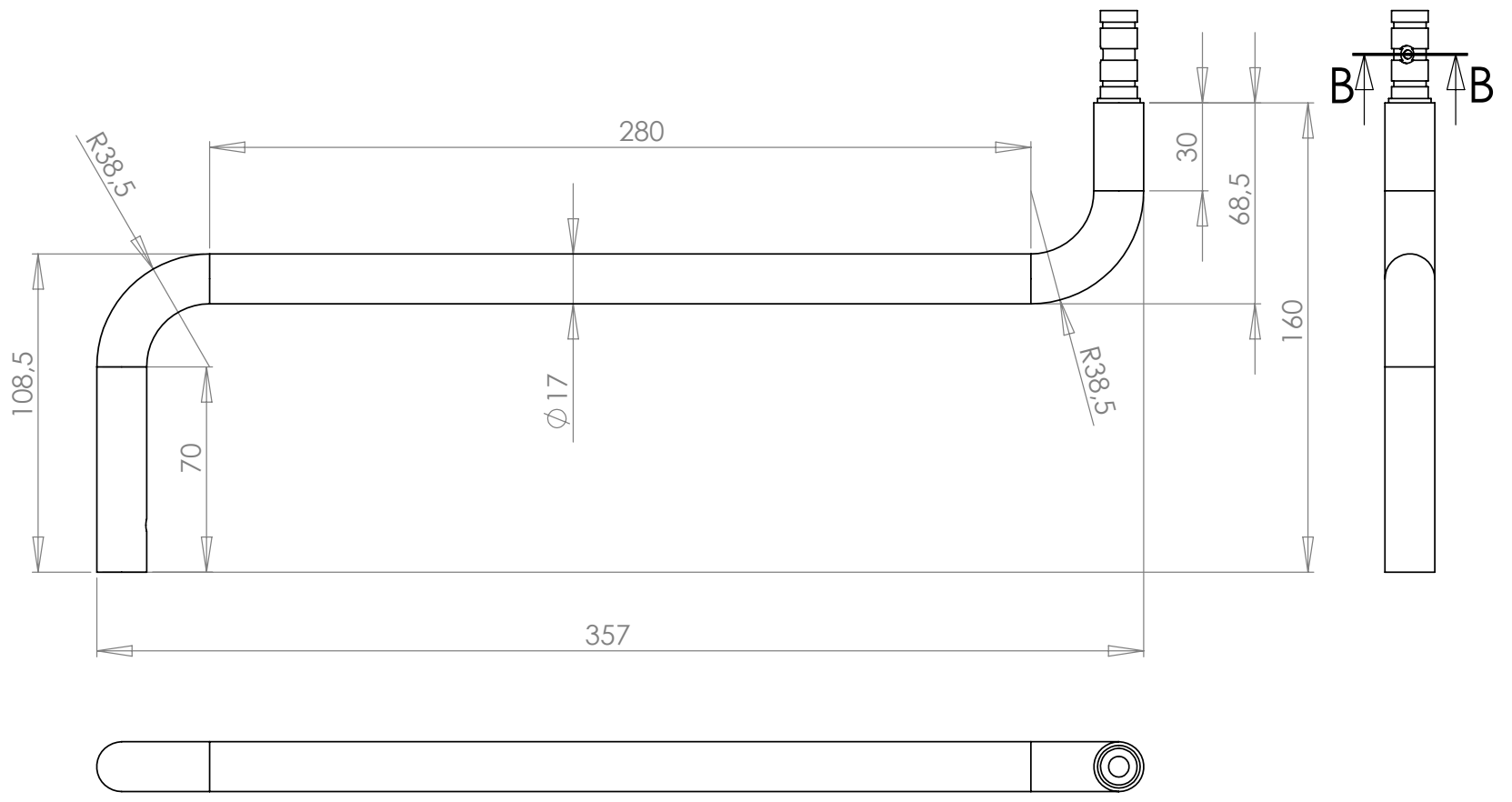
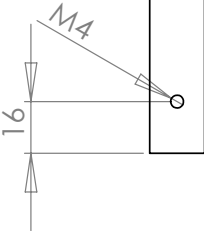
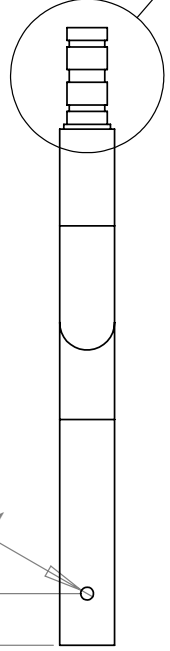
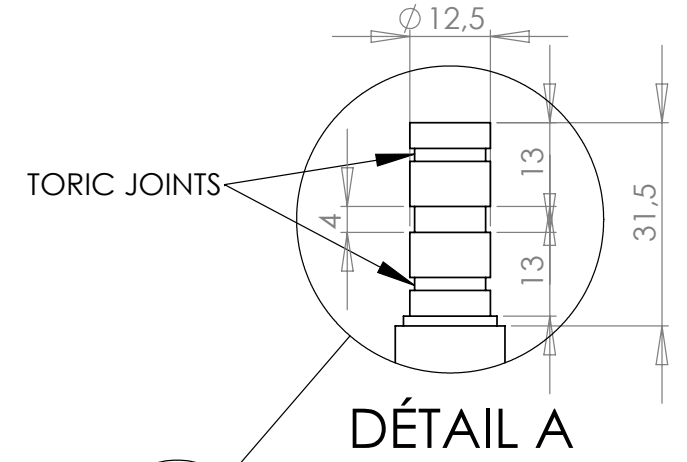

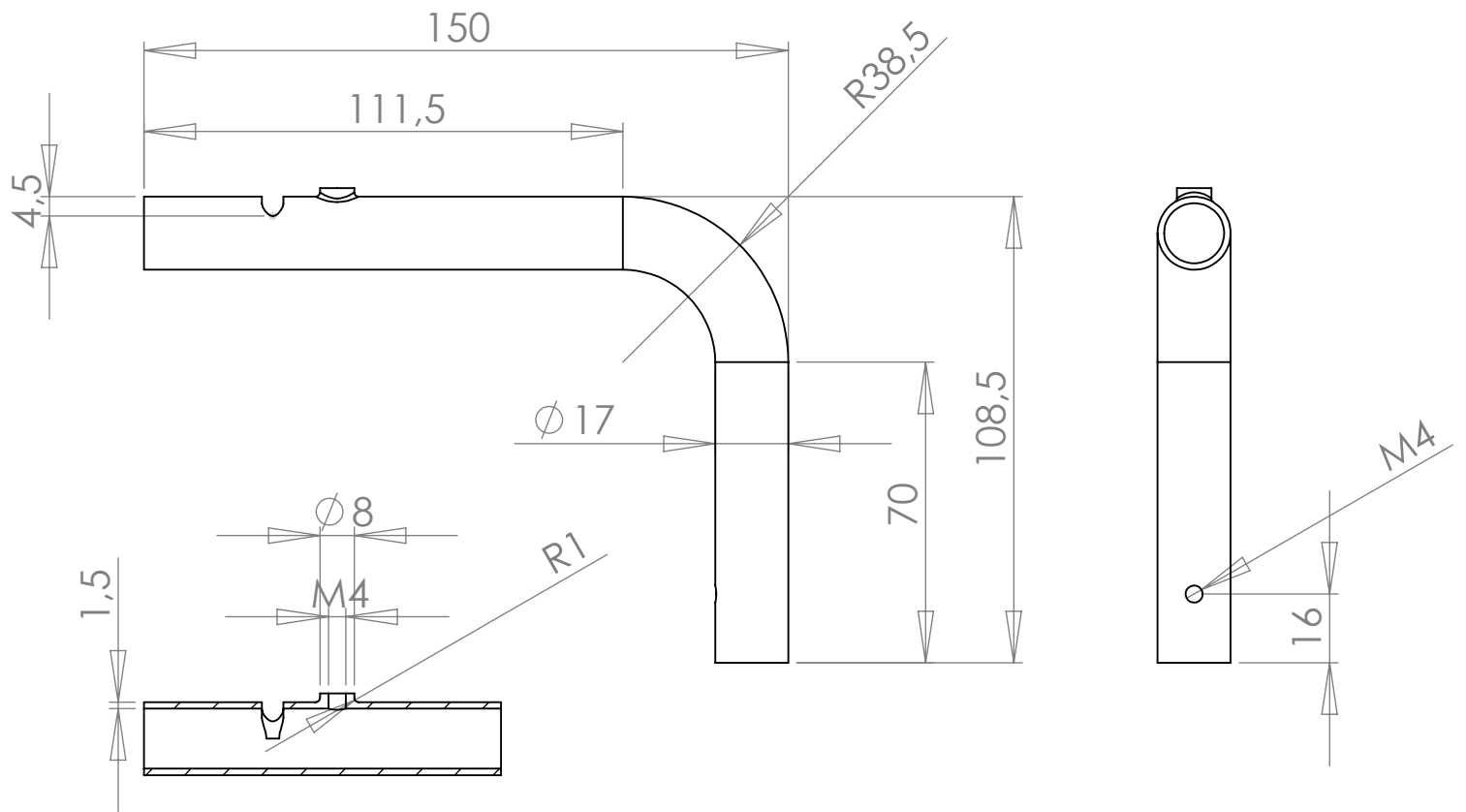

COUPE A-A

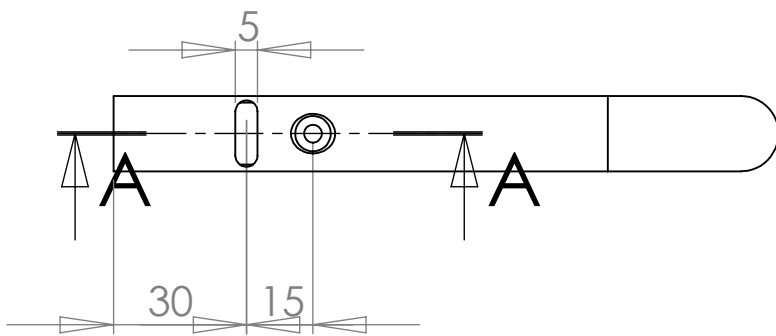

dcw.

Name : LAMP GRAS

Matériaux : PAINTED STEEL/CHROMED STEEL

Part : L TUBE – 150

Date : 17/01/2013

Rev : 1

Details :

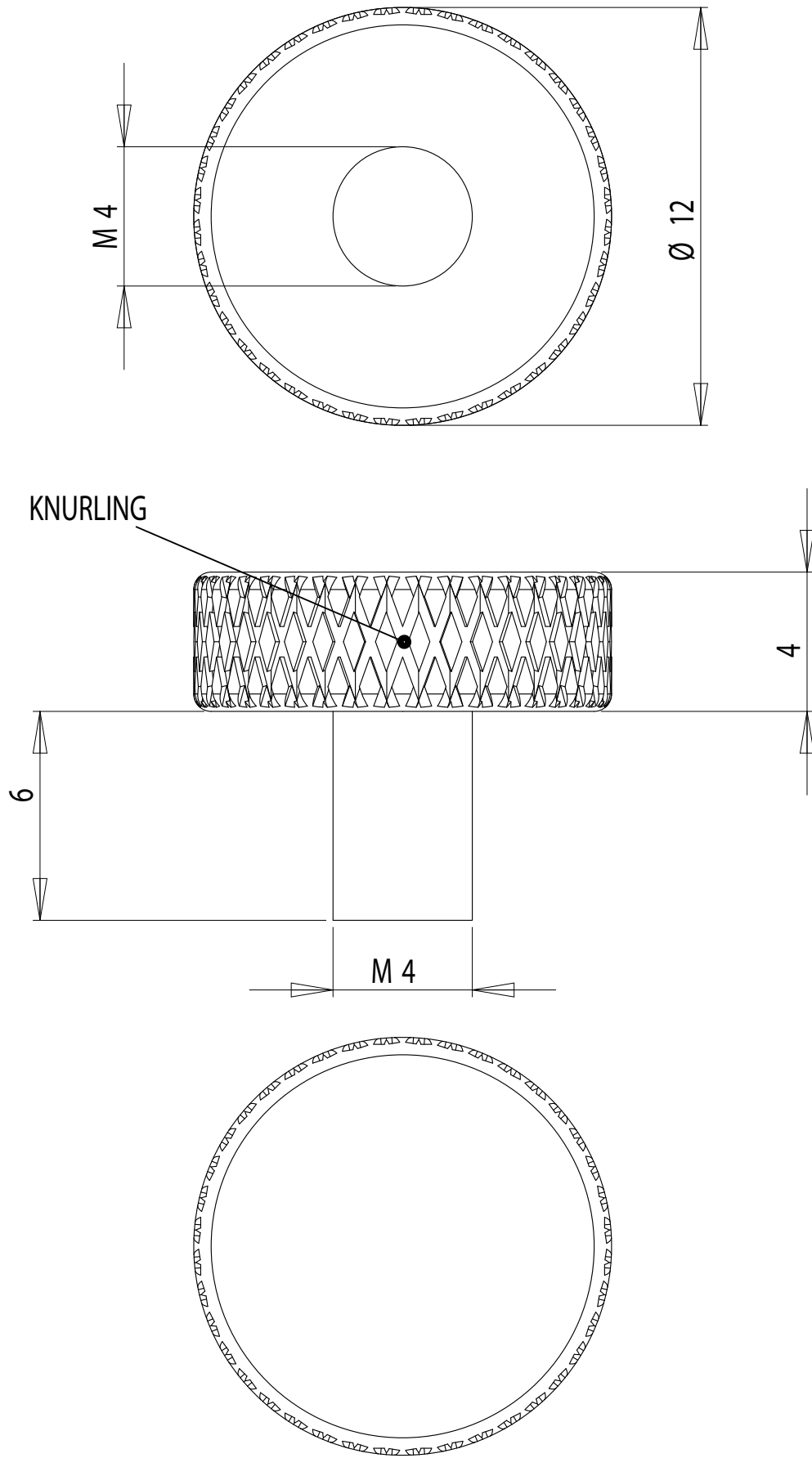

dcw.

Name : **LAMP GRAS**

Materials : PAINTED STEEL

Part : **BREAKING HANDLE**

Date : 17/01/2013

Rev : 1

Details :

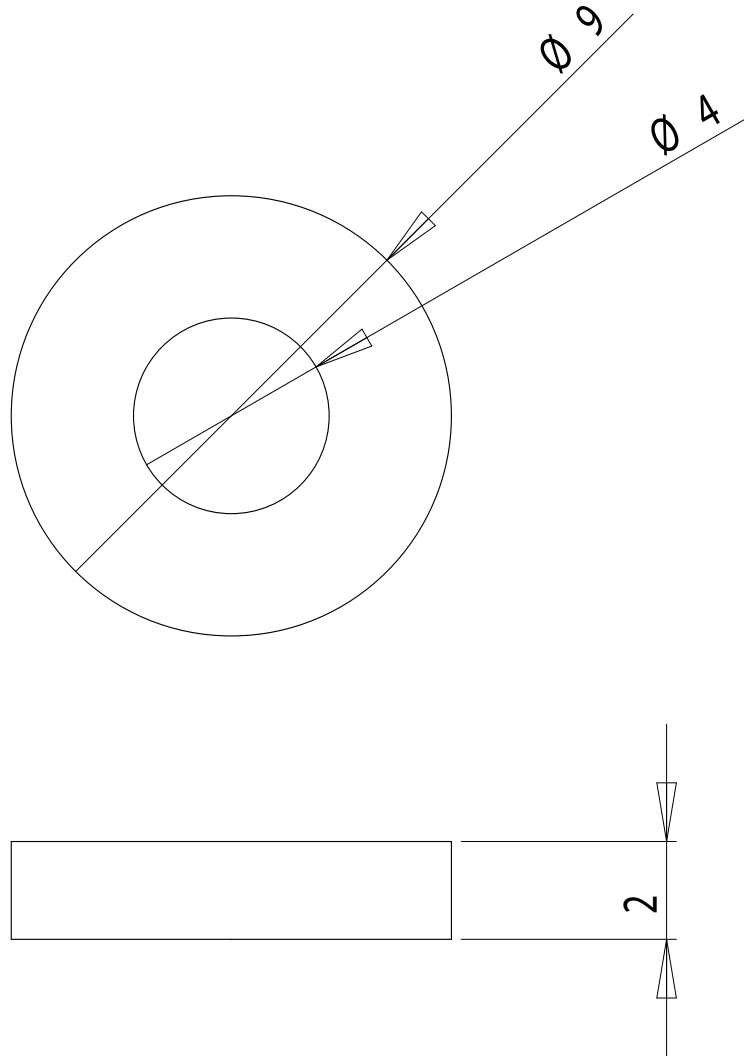

dcw.

Name : **LAMP GRAS**

Matériaux : PLASTIC

Part : **HANDLE WASHER**

Date : 17/01/2013

Rev : 1

Details :

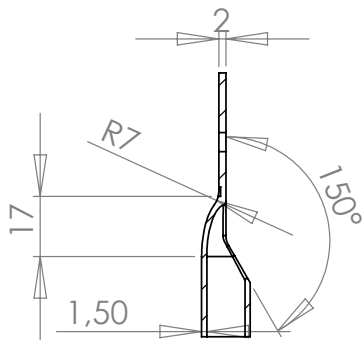

COUPE C-C

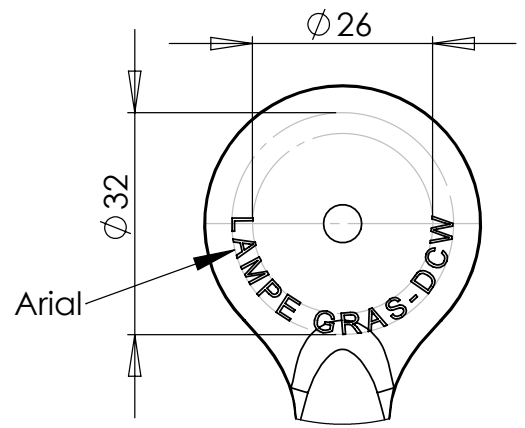

DÉTAIL B

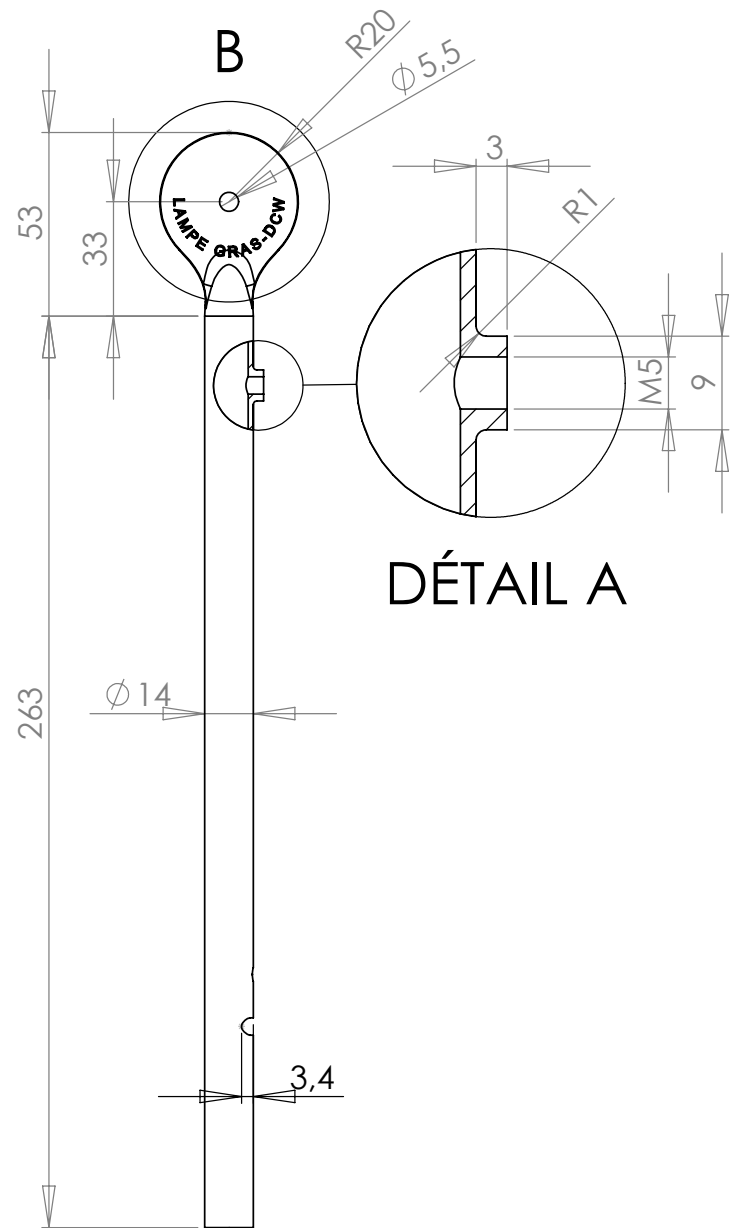
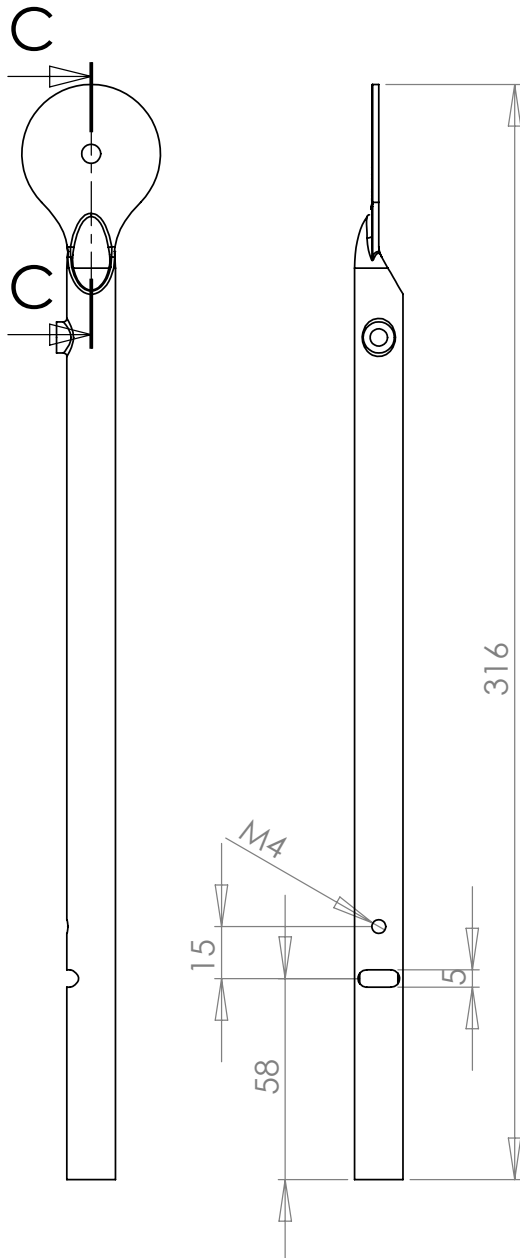

DÉTAIL A

dcw.

Name : LAMP GRAS

Matériaux : PAINTED STEEL/CHROMED STEEL

Part : TUBE 1 – 316

Date : 17/01/2013

Rev : 1

Details :

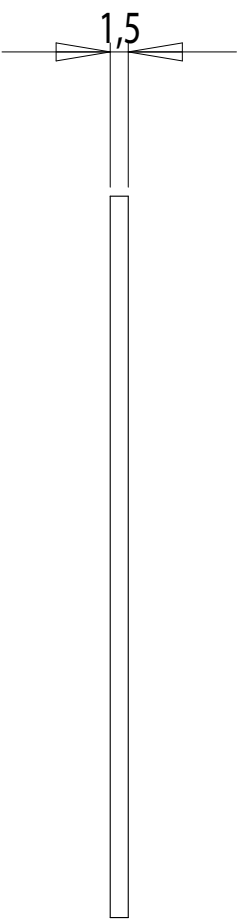
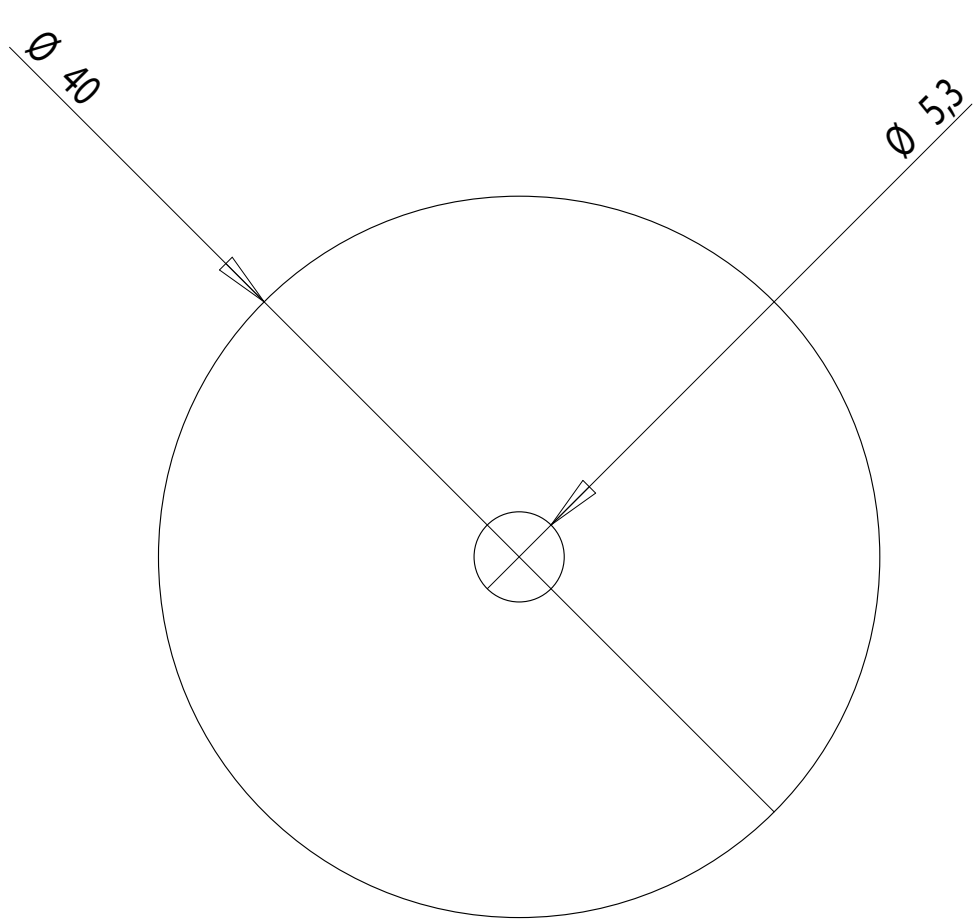

PLIERS SUPPLIED BY DCW

dcw.

Name : LAMP GRAS

Materials : PLASTIC

Part : PLASTIC WASHER – Ø40

Date : 17/01/2013

Rev : 1

Details :

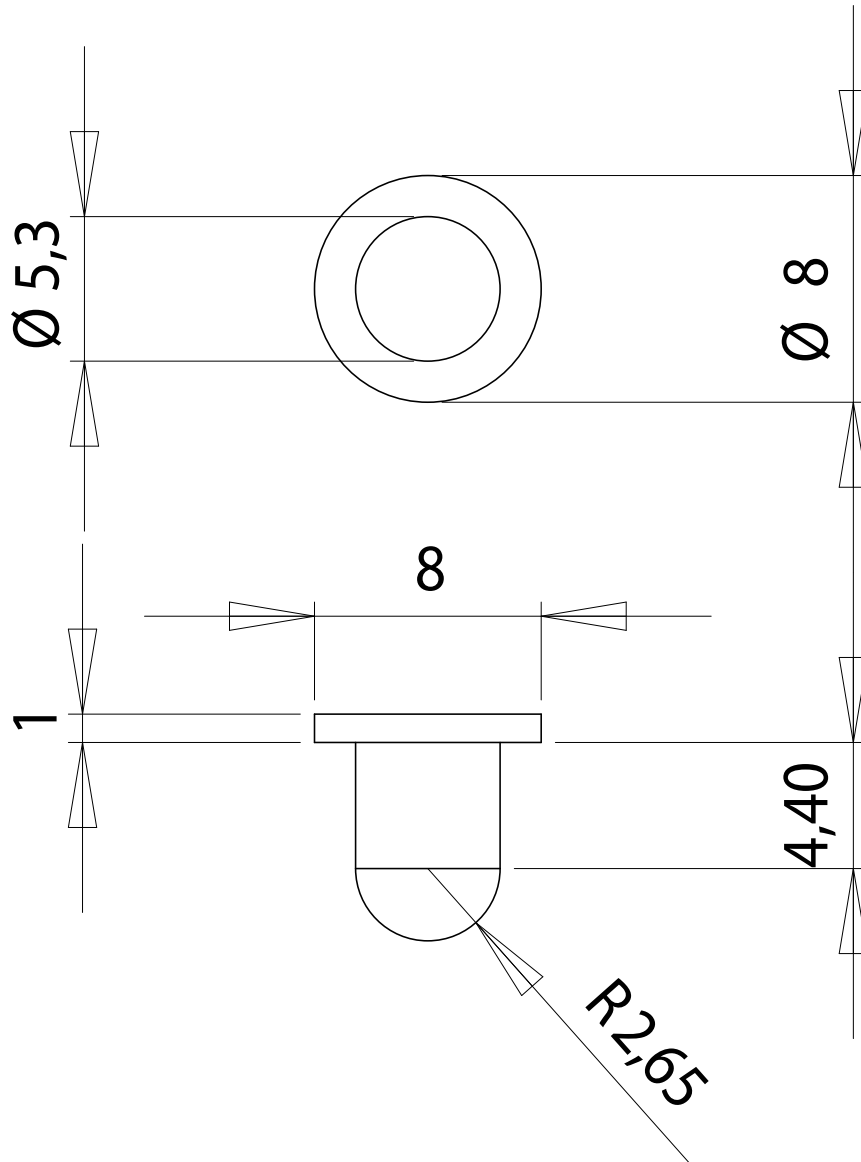

dcw.

Name : LAMP GRAS

Materials : CHROMED STEEL

Part : AXIS

Date : 17/01/2013

Rev : 1

Details :

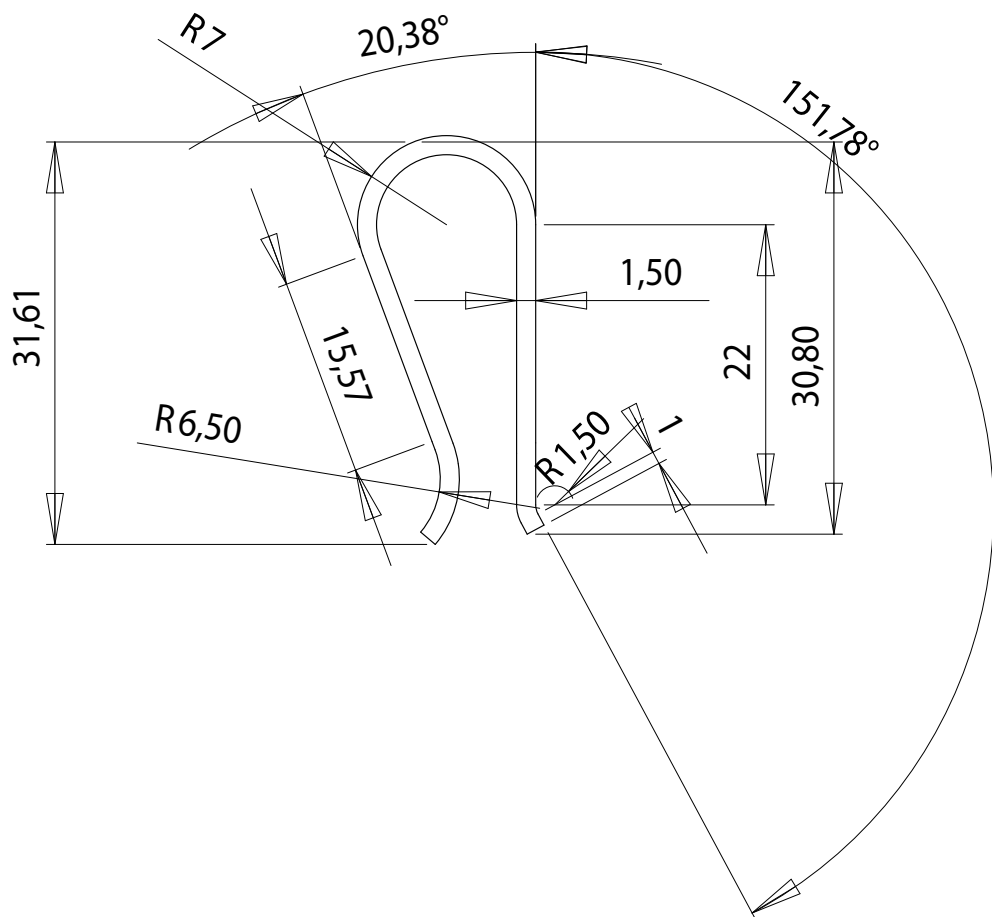
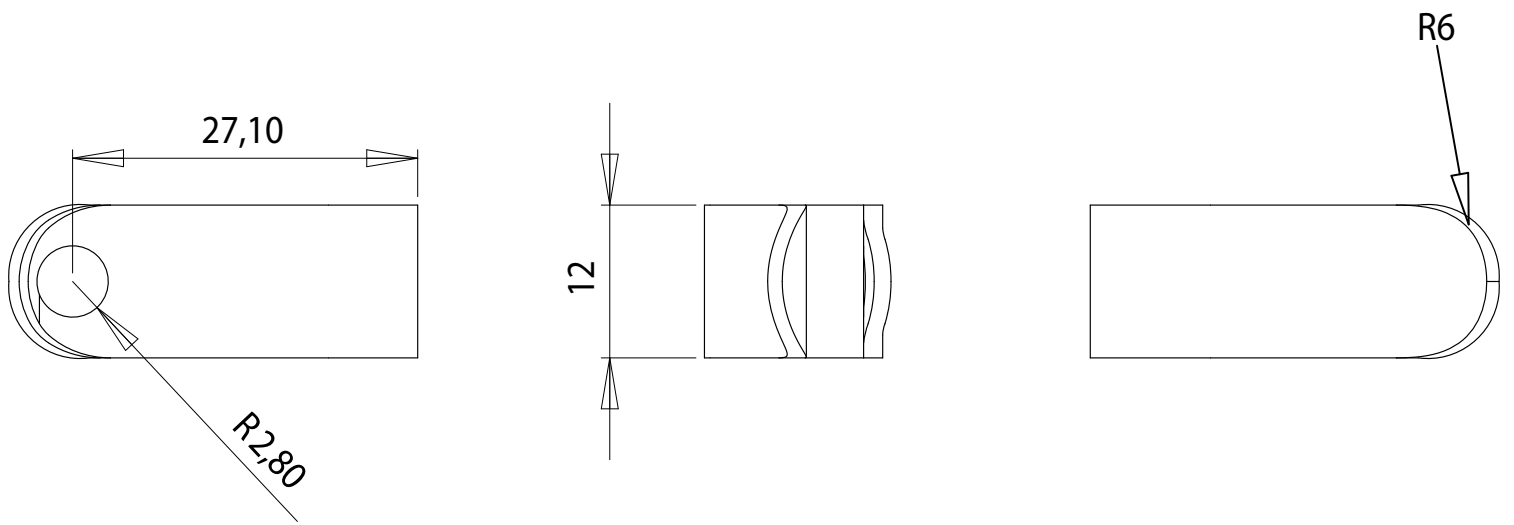

PLIERS SUPPLIED BY DCW

dcw.

Name : LAMP GRAS

Materials : SPRING PAINTED STEEL / CHROMED STEEL

Part : PLIERS

Date : 17/01/2013

Rev : 1

Details :

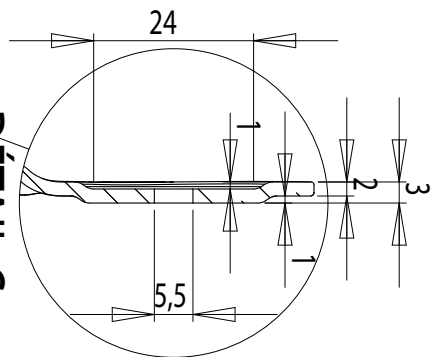

DETAIL C

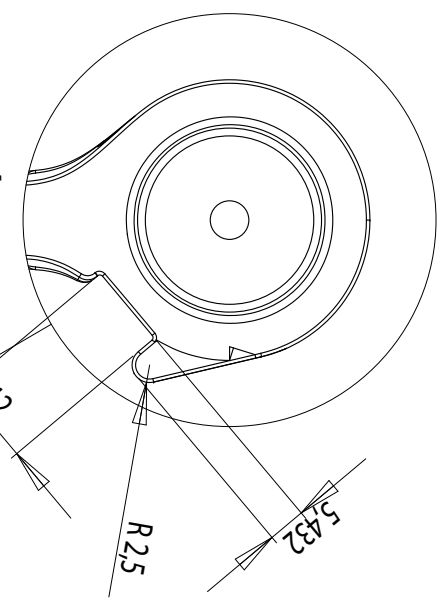

DETAIL A

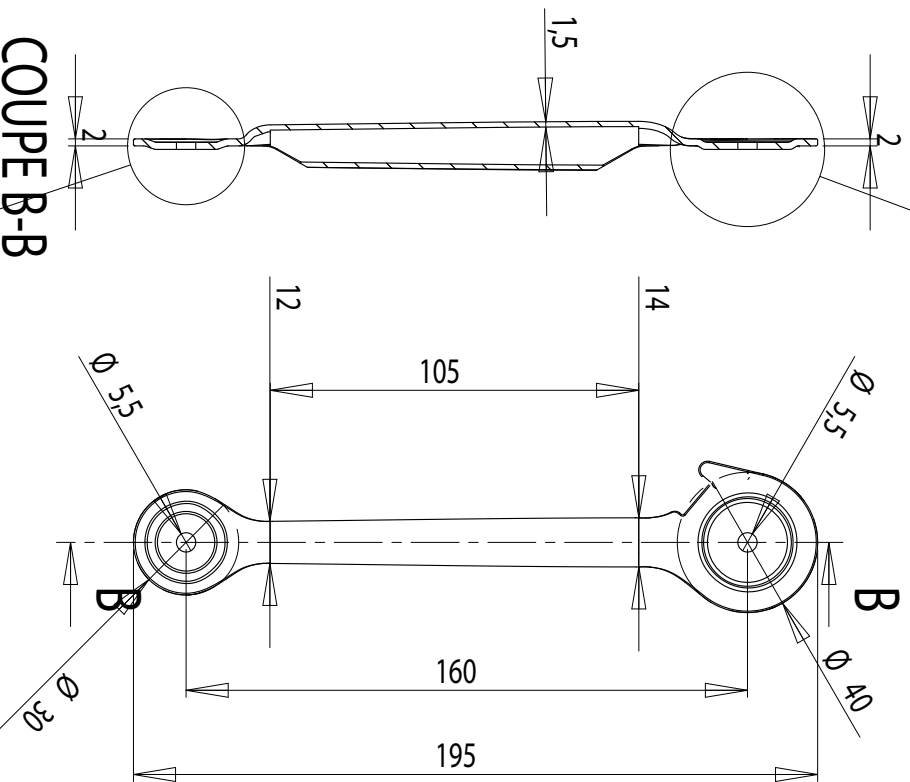

COUPE B-B

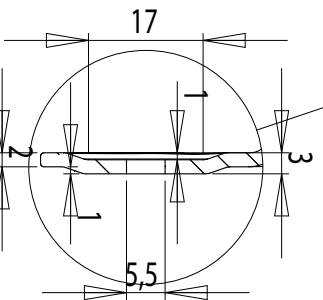
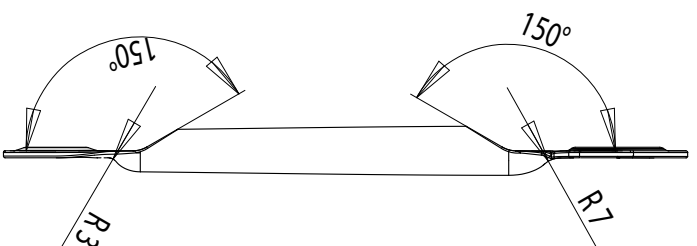

DETAIL D



Name : LAMP GRAS

Materials : PAINTED STEEL/CHROMED STEEL

dcw.

Part : TUBE 2

Date : 17/01/2013

Rev : 1

Details :

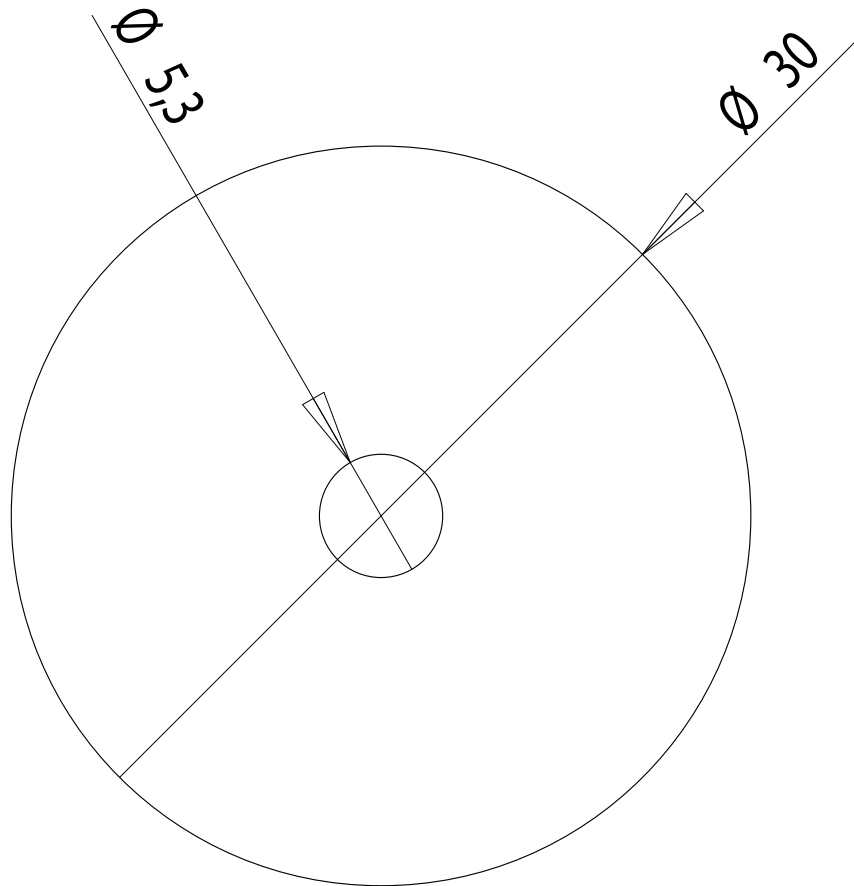

PLIERS SUPPLIED BY DCW

dcw.

Name : LAMP GRAS

Materials : PLASTIC

Part : PLASTIC WASHER – $\varnothing 30$

Date : 17/01/2013

Rev : 1

Details :

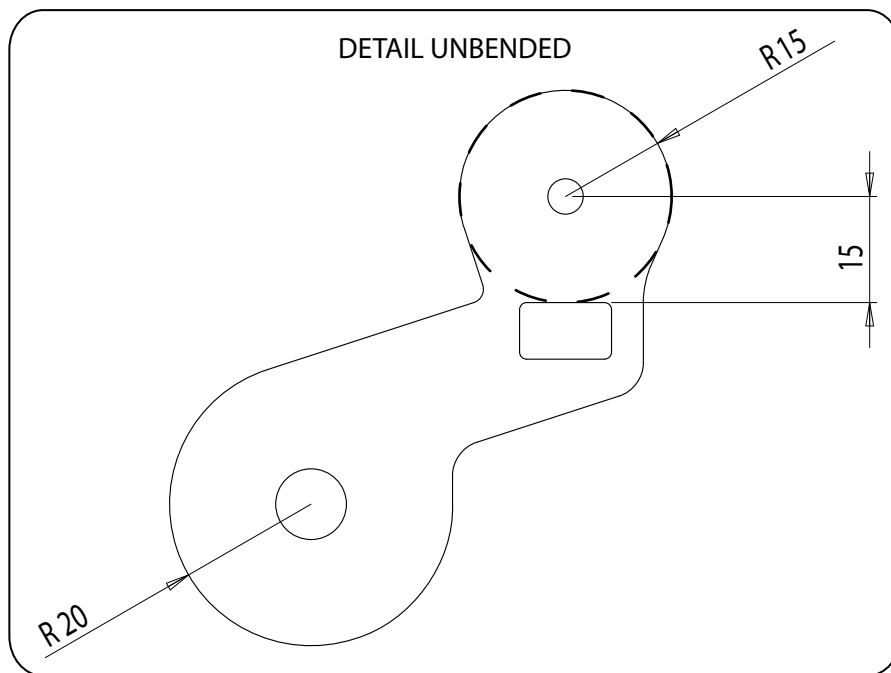
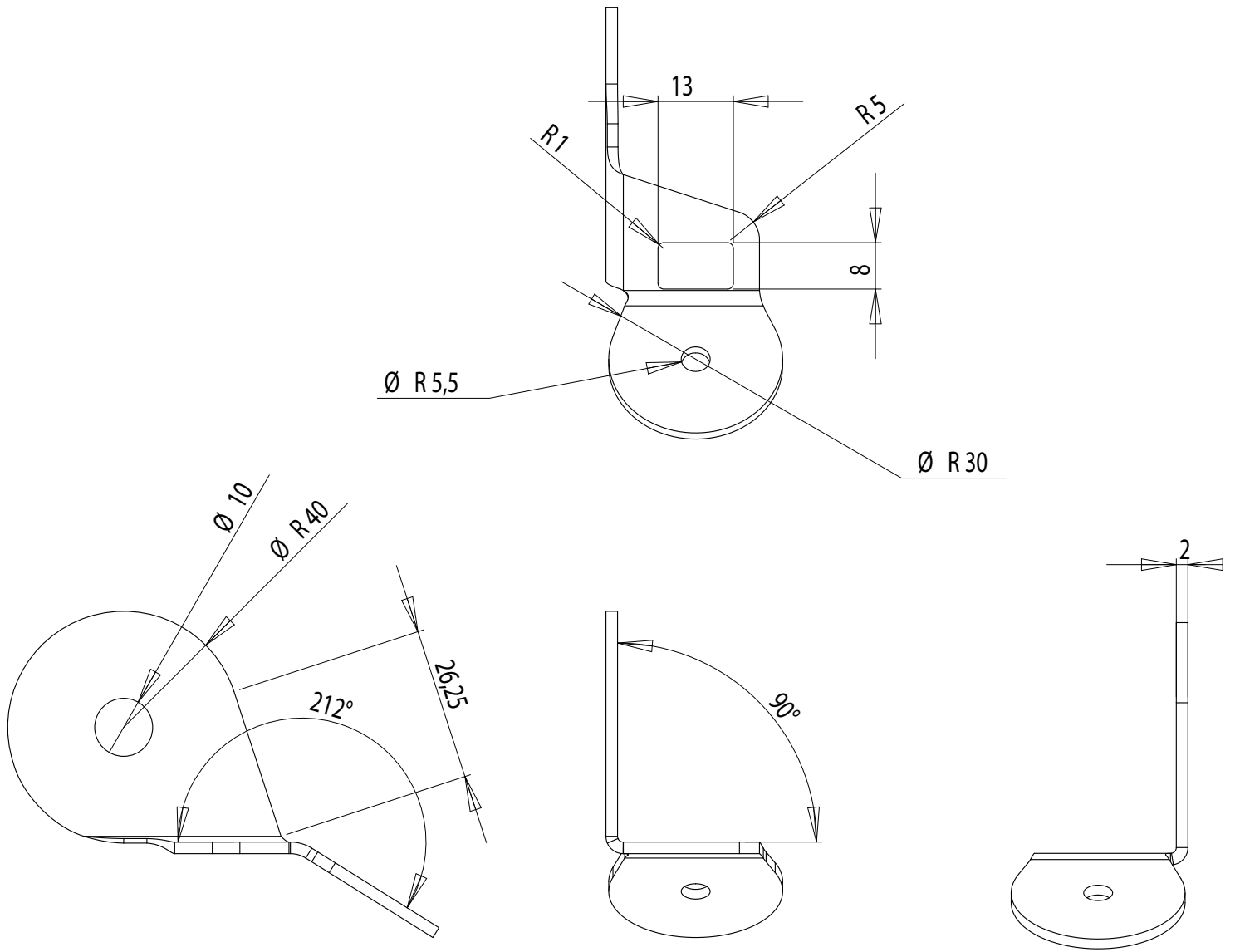

dcw.

Name : **LAMP GRAS**

Materials : PAINTED STEEL / CHROMED STEEL

Part : **JUNCTION PIECE**

Date : 17/01/2013

Rev : 1

Details :

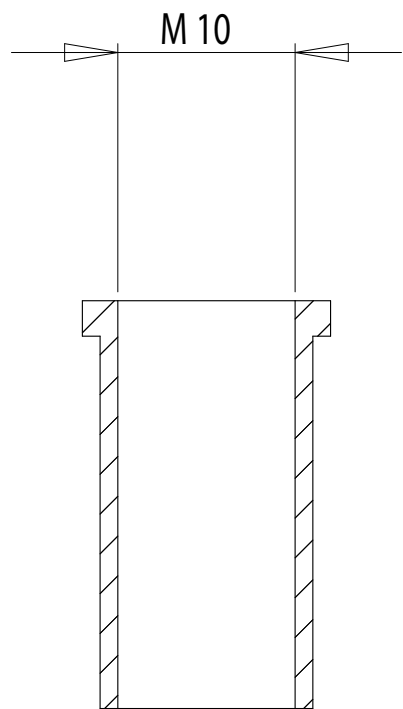
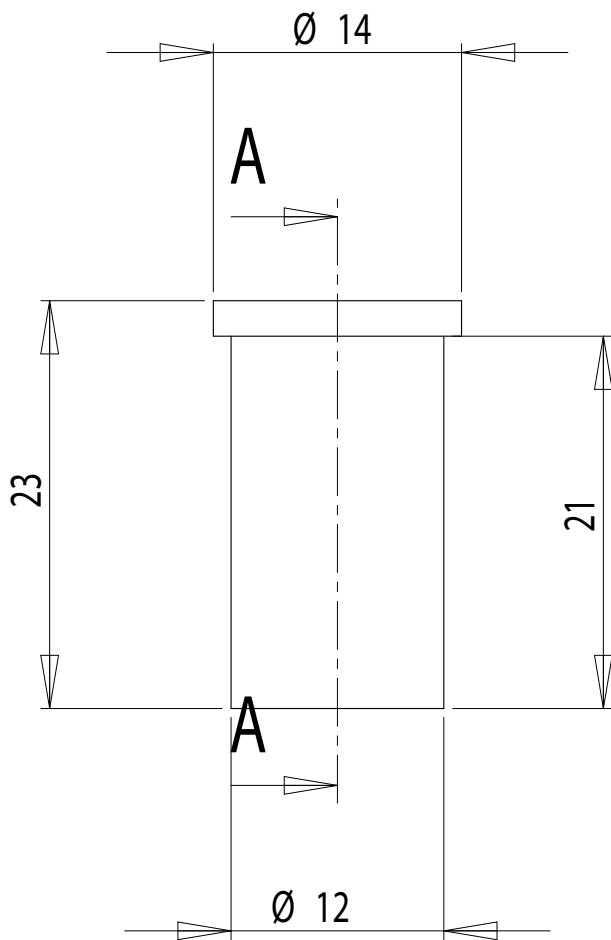

COUPE A-A

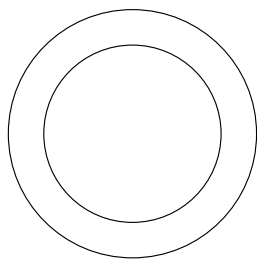

dcw.

Name : **LAMP GRAS**

Part : **FIXATION PIECE**

Date : 17/01/2013

Rev : 1

Materials : PAINTED STEEL / CHROMED STEEL

Details :

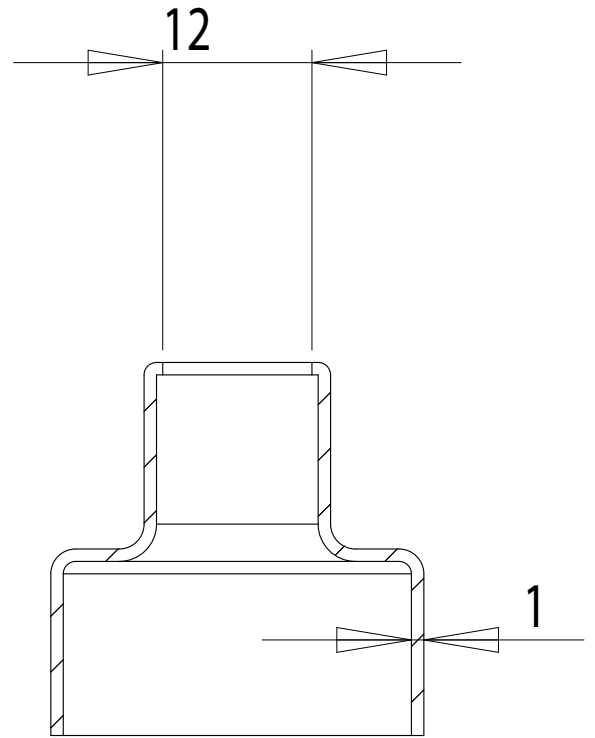
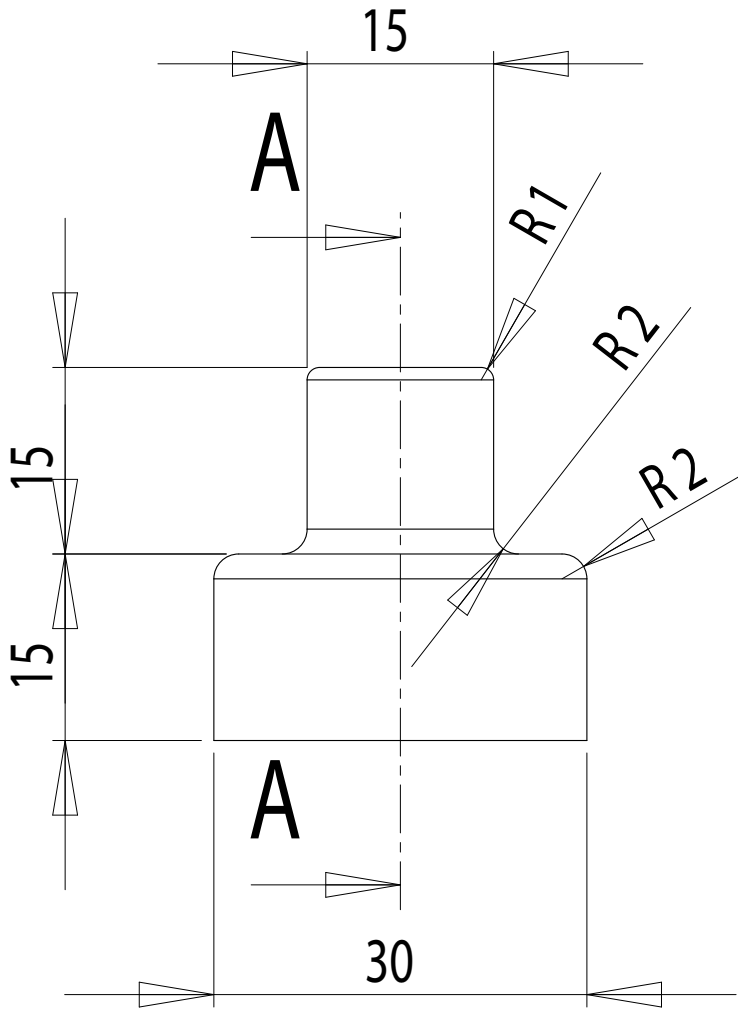

COUPE A-A

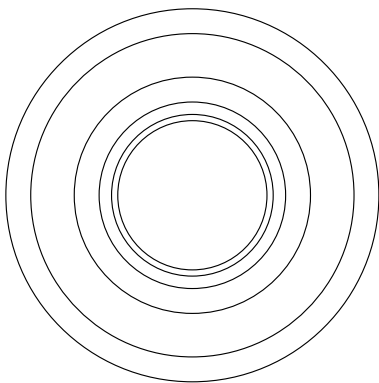

dcw.

Name : **LAMP GRAS**

Materials : PAINTED STEEL / CHROMED STEEL

Part : **COVERING PIECE**

Date : 17/01/2013

Rev : 1

Details :

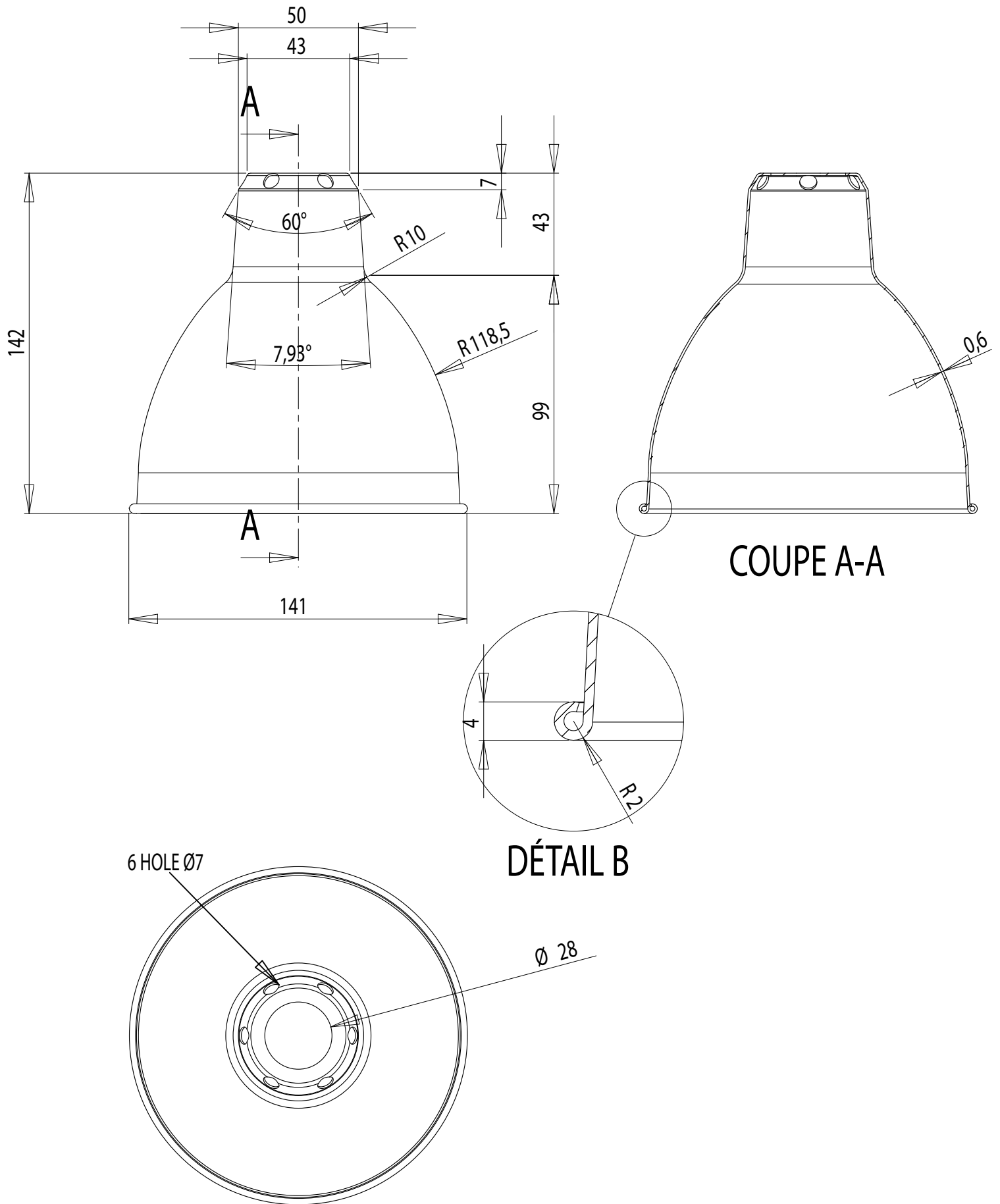

dcw.

Name : **LAMP GRAS**

Materials : PAINTED STEEL/CHROMED STEEL

Part : **ROUND SHADE**

Date : 17/01/2013

Rev : 1

Details :

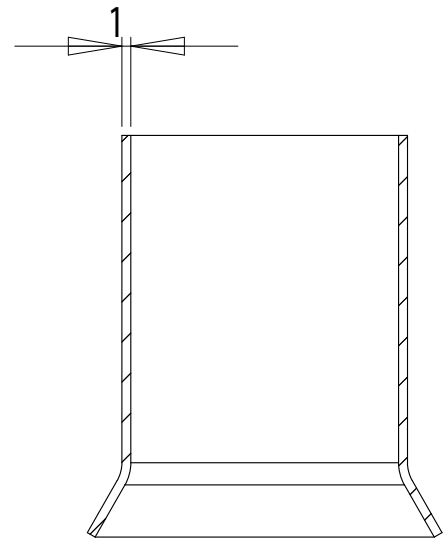
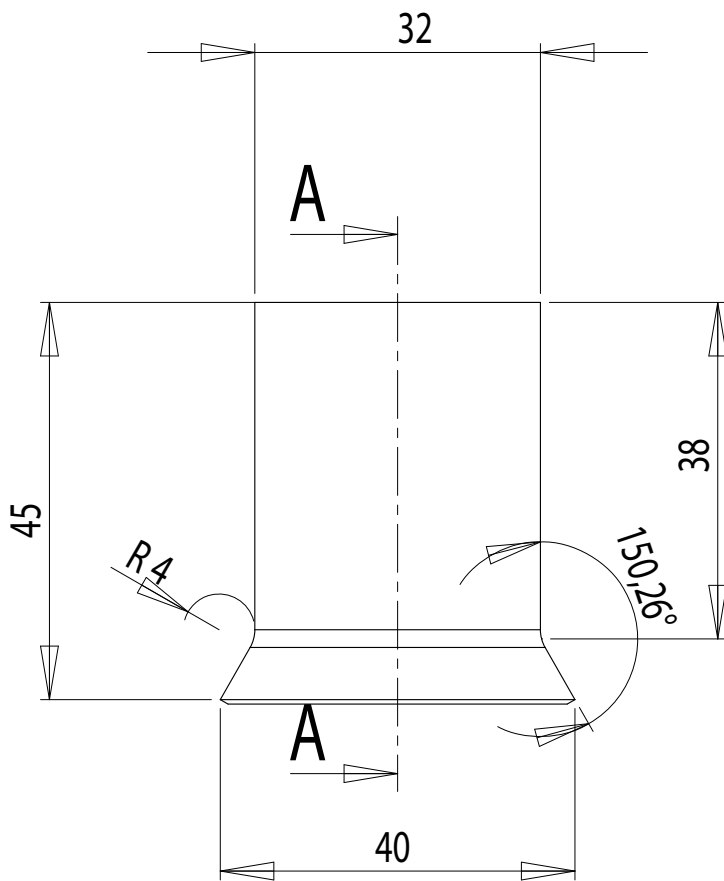
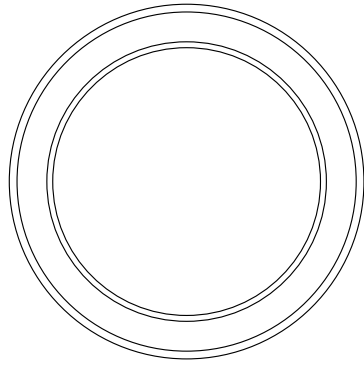

COUPE A-A

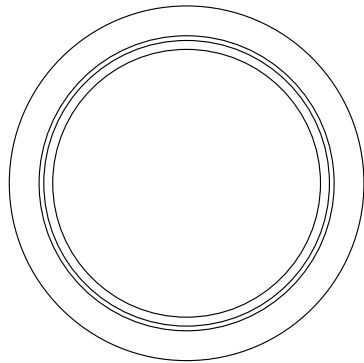

dcw.

Name : LAMP GRAS

Materials : PAINTED STEEL / CHROMED STEEL

Part : BULBHOLDER SPACER

Date : 17/01/2013

Rev : 1

Details :