



Qty	Piece	Finishing
1	WALL PIECE	BLACK SATIN
1	WALL PIECE 2	BLACK SATIN
2	BELLEVILLE WASHER	
1	SPHERE	BLACK
1	BALL BREAKER	
1	RUBBER	BLACK
1	CORD GRIPP	BLACK
1	TUBE 1	BLACK SATIN
1	CABLE EXIT	BLACK
1	SHADE WASHER	BLACK SATIN
1	COVERING PIECE	BLACK SATIN
1	FIXATION PIECE	CHROME
1	ROUND SHADE	BLACK OUTSIDE / WHITE INSIDE
1	BULBHOLDER SPACER	

dcw.

Name : LAMP GRAS N°330 BL-SAT

Matérials :

Part :

Date :

Rev : 1

Details : E14 - 11w ; Ardití métal bulbholder ; Black fabric wire

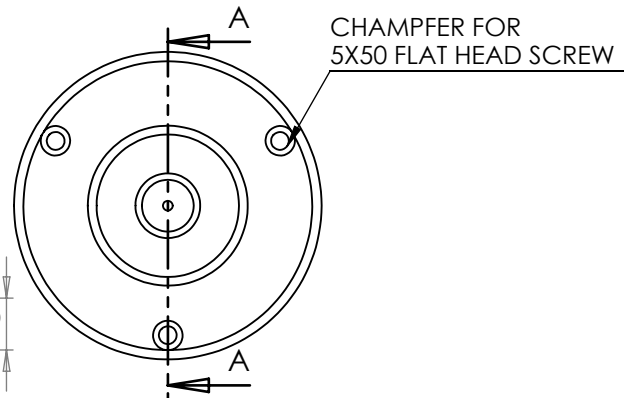
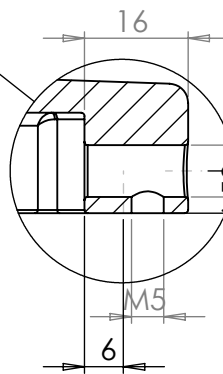
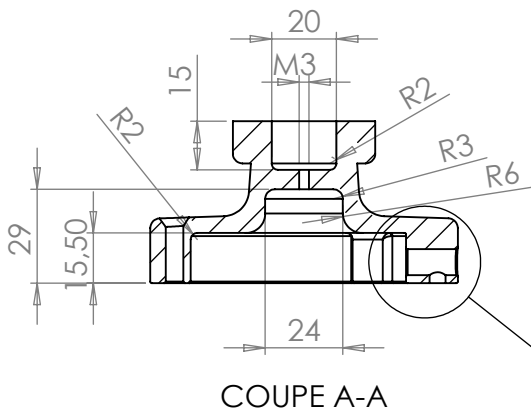
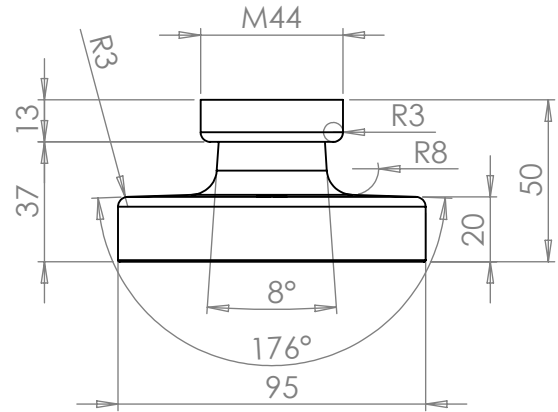
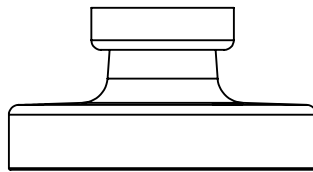
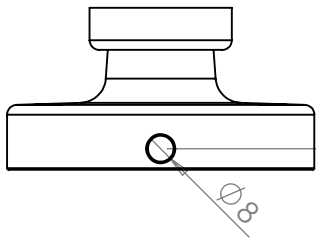
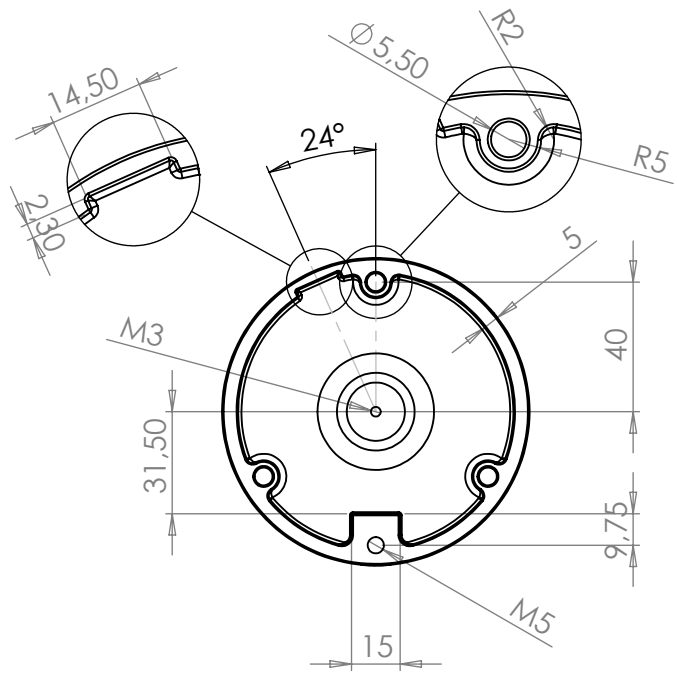
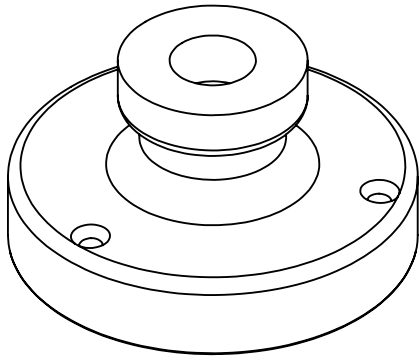

dcw.

Name : LAMP GRAS N°302/304

Materials : PAINTED STEEL

Part : WALL PIECE

Date :

Rev : 1

Details :

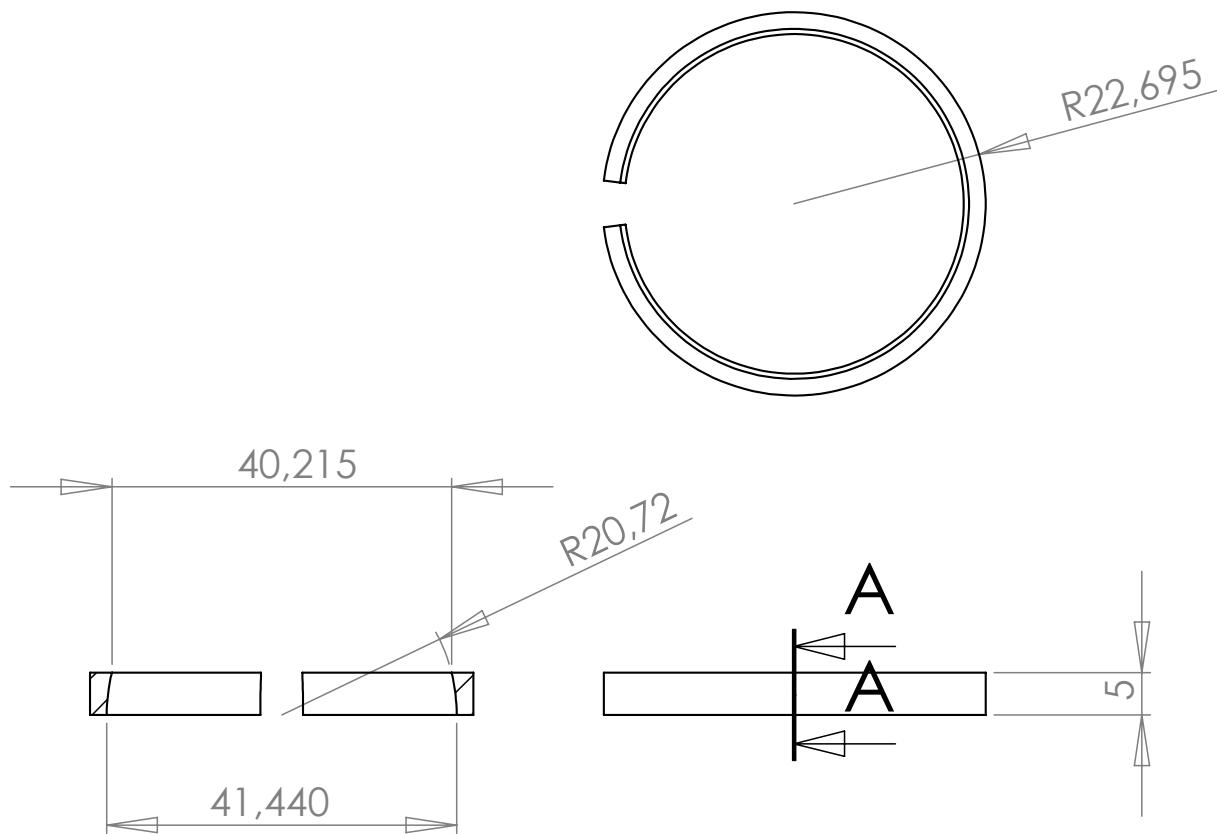

COUPE A-A

dcw.

Name : **LAMP GRAS**

Matériaux : PA 6

Part : **BREAKING RING**

Date :

Rev : 1

Details :

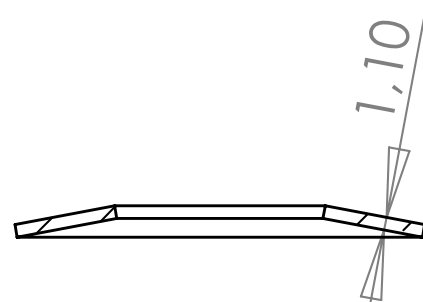
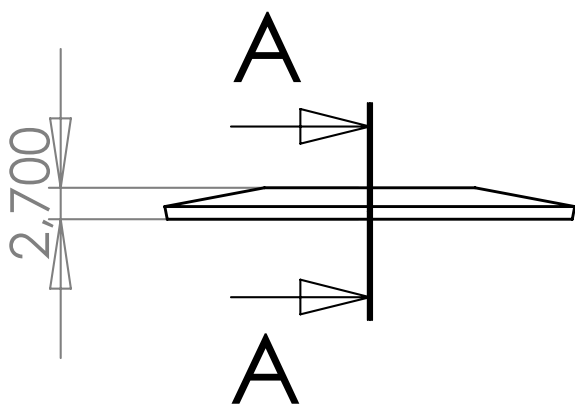
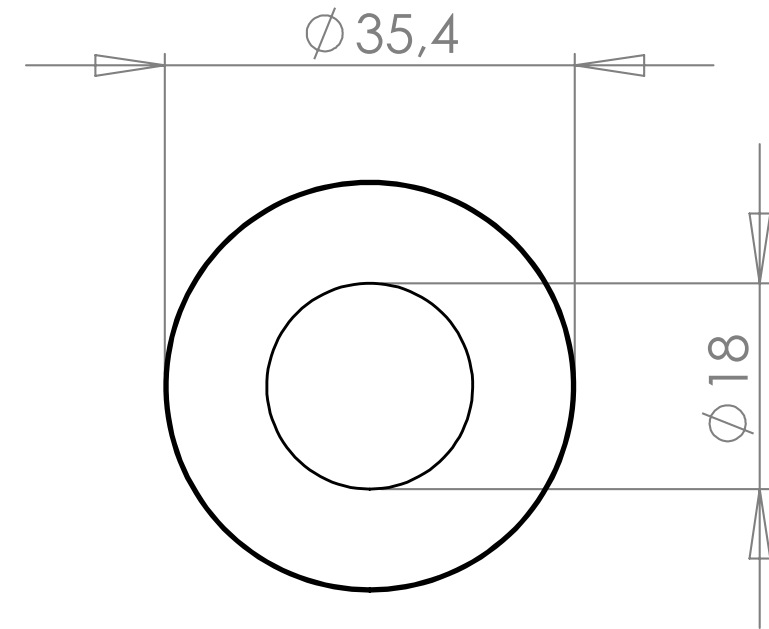

COUPE A-A

dcw.

Name : LAMP GRAS

Matériaux : SPRING STEEL

Part : BELLEVILLE WASHER

Date :

Rev : 1

Details :



CELERON

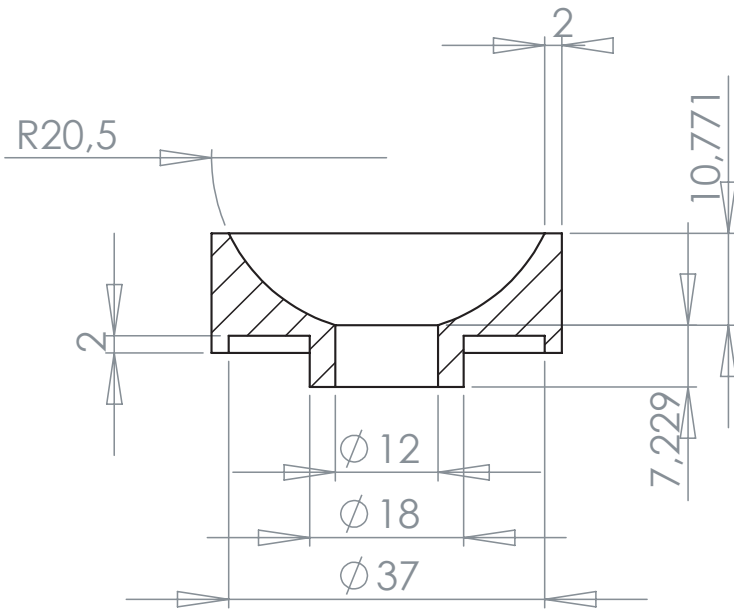
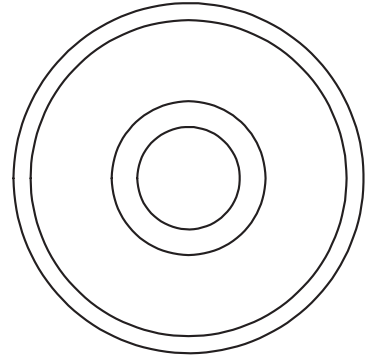

COUPE A-A

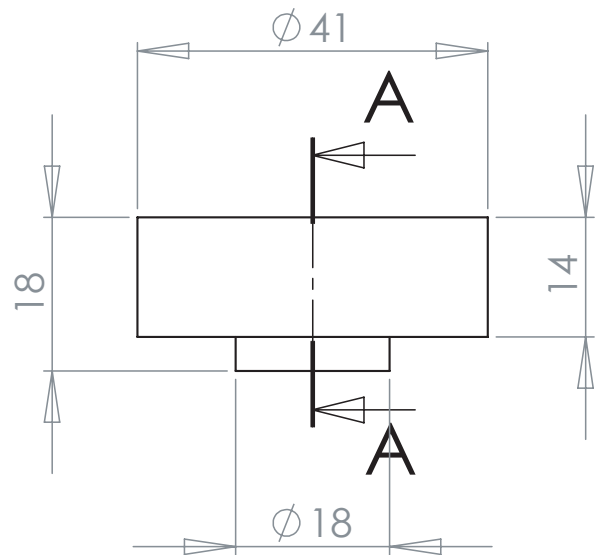

dcw.

Name : LAMP GRAS

Matériaux : CELERON / THERMOPLASTIC RESIN

Part : BALL BREAKER NEW

Date :

Rev : 1

Details :

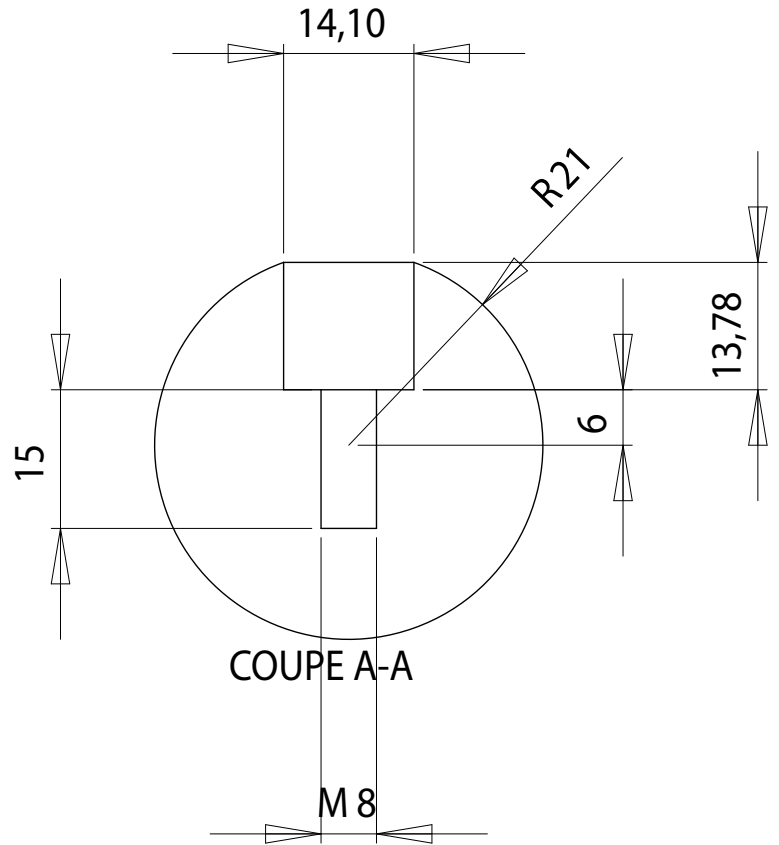
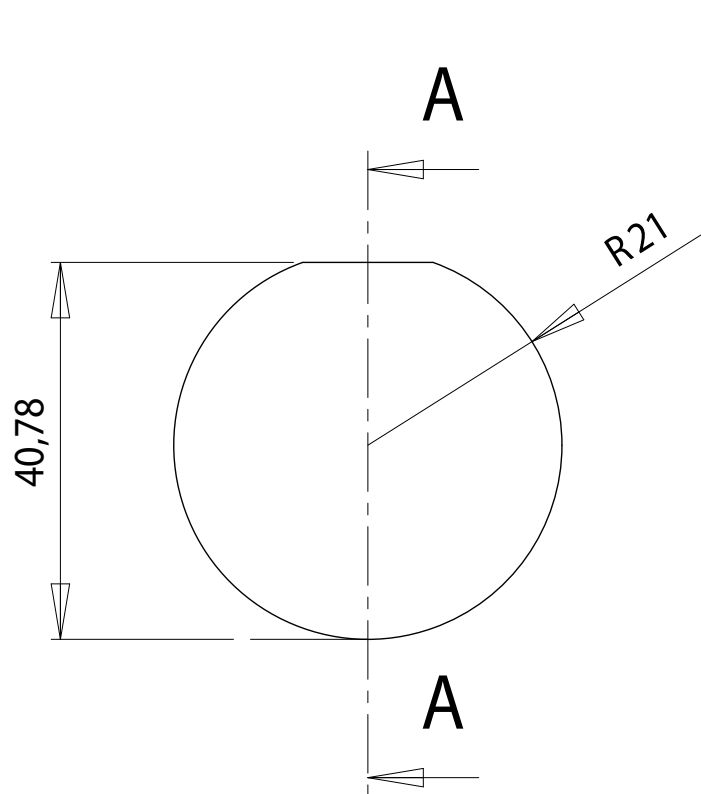

dcw.

Name : LAMP GRAS

Matériaux : BLACK BAKELITE

Part : SPHERE

Date :

Rev : 1

Details :

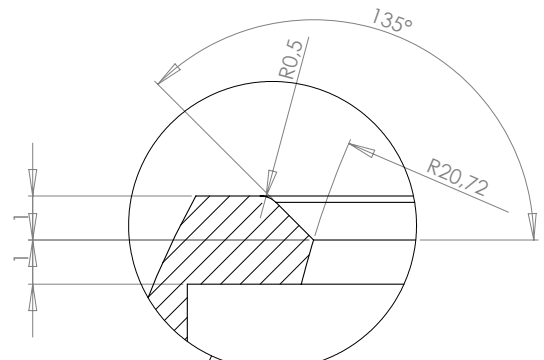
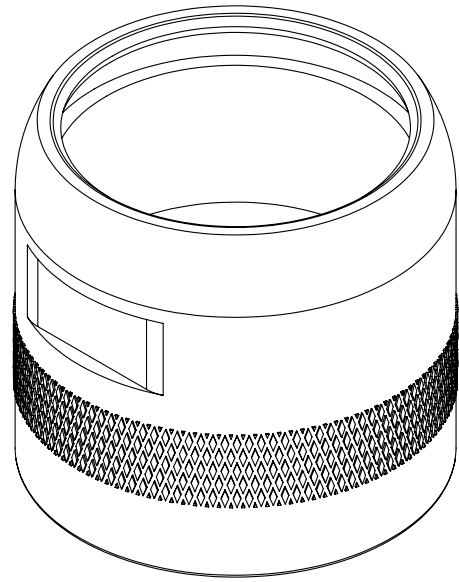
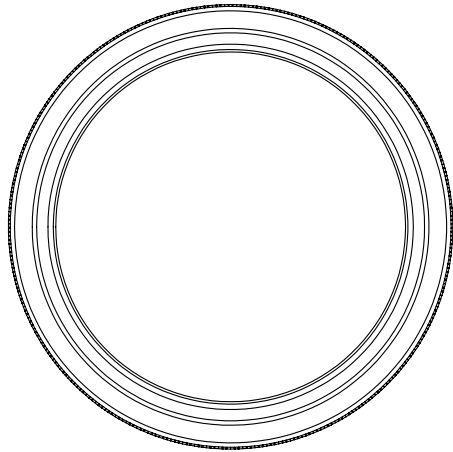

DÉTAIL B

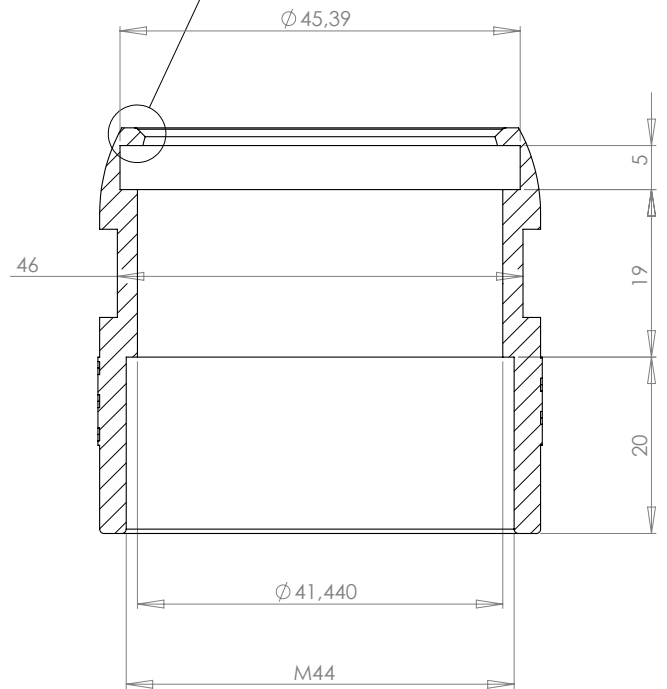
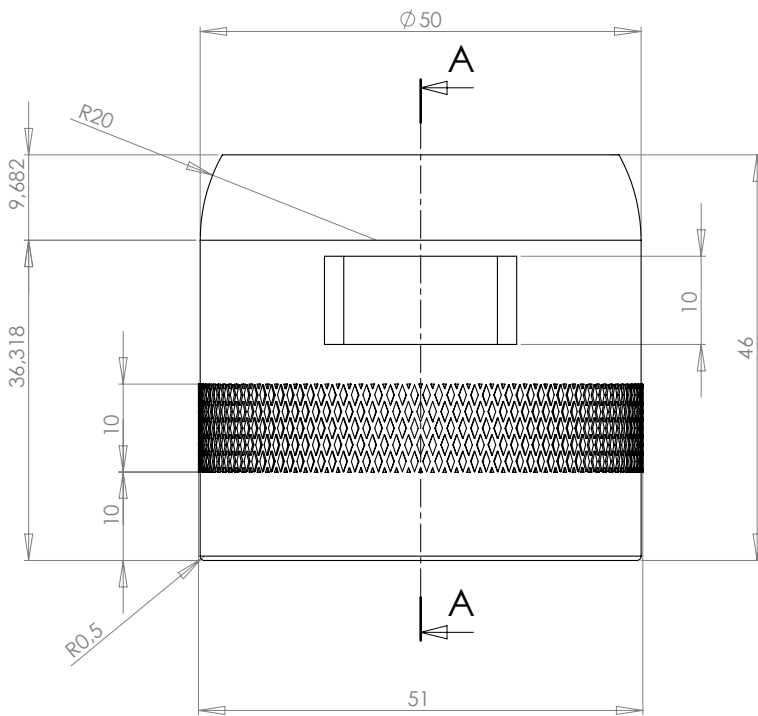

COUPE A-A

dcw.

Name : LAMP GRAS

Matériaux : PAINTED STEEL

Part : WALL PIECE 2 NEW

Date :

Rev : 1

Details :

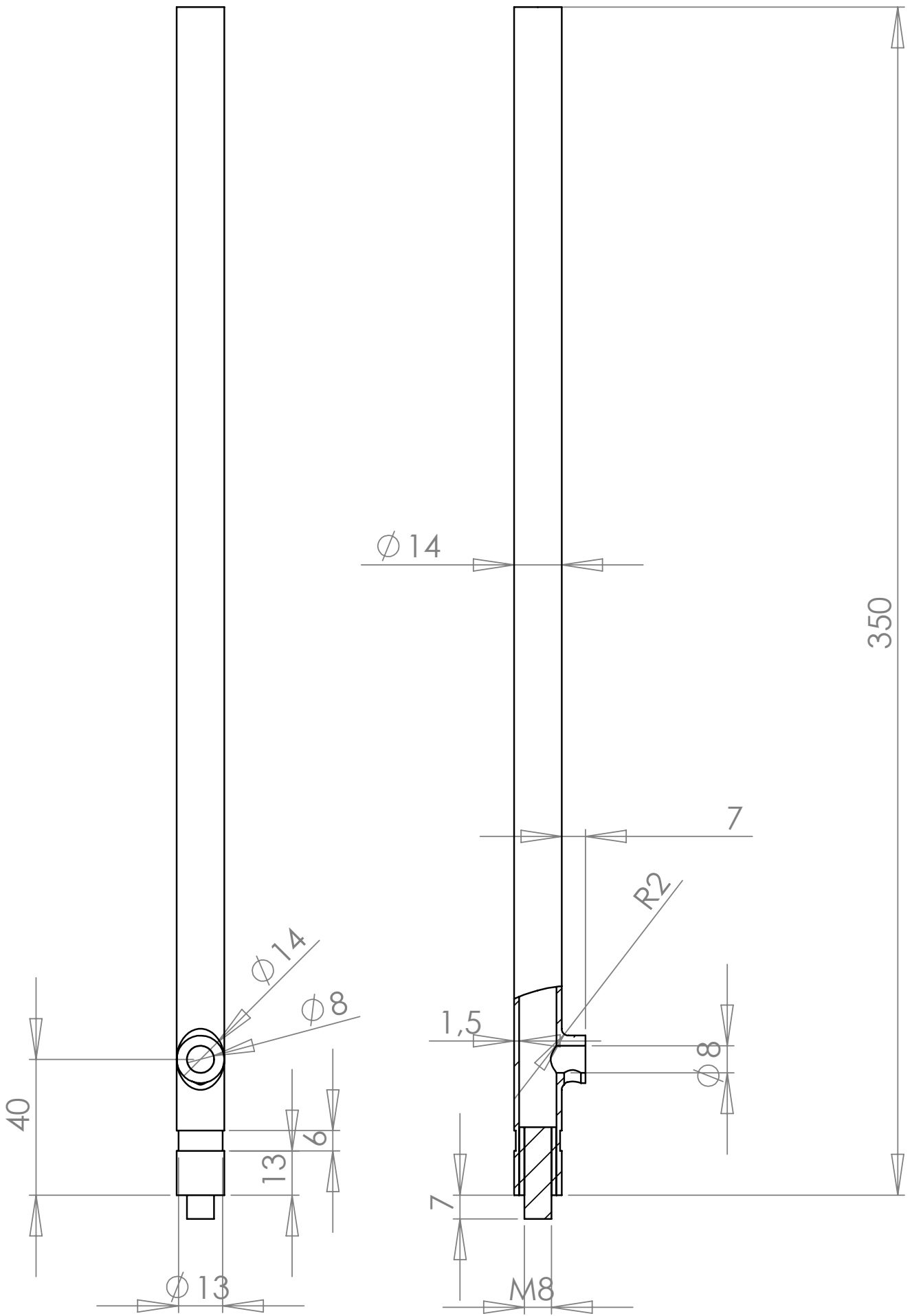

dcw.

Name : LAMP GRAS N330

Materials : PAINTED STEEL

Part : TUBE 1

Date :

Rev : 1

Details :

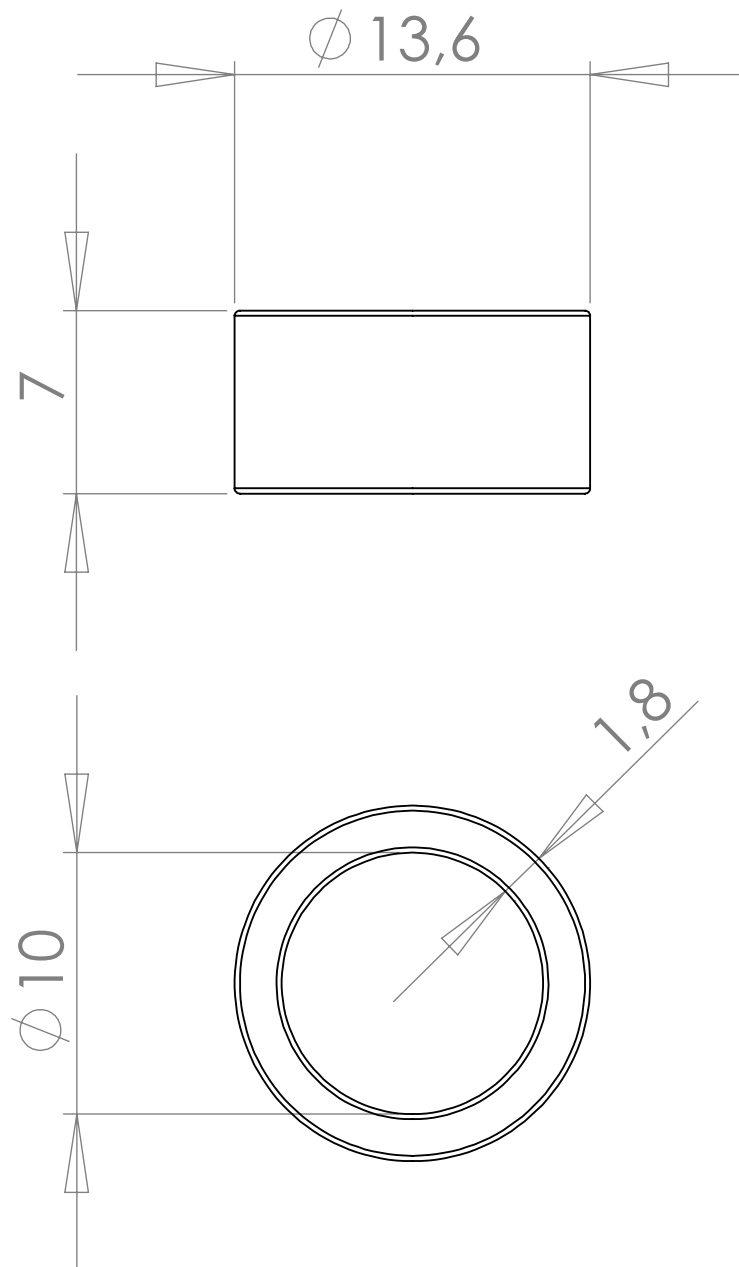

dcw.

Name : **LAMP GRAS**

Matériaux : RUBBER

Part : **RUBBER**

Date :

Rev : 3

Details :

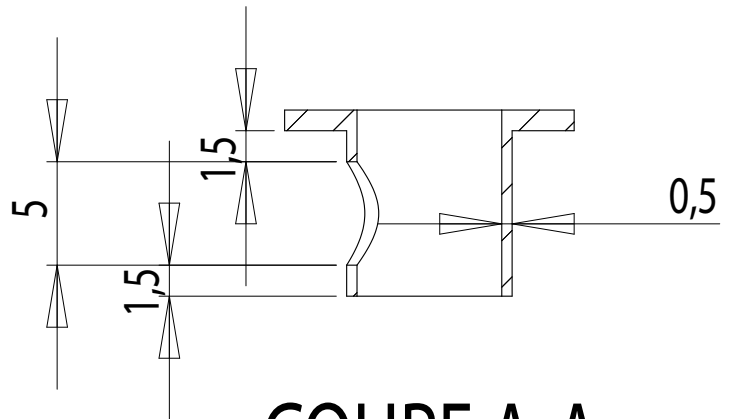
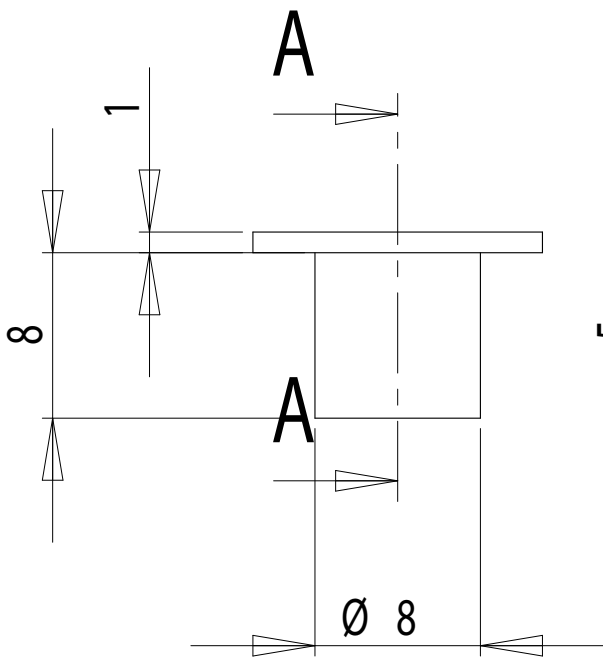
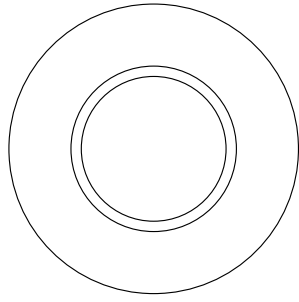

COUPE A-A

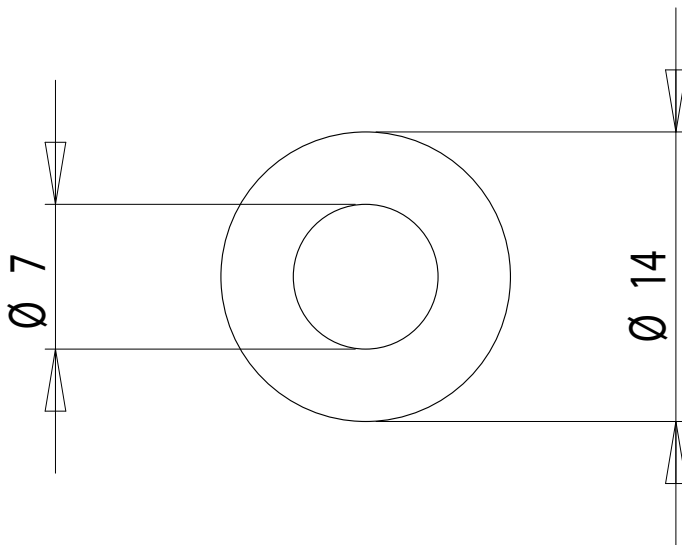

dcw.

Name : **LAMP GRAS**

Materials : BLACK PLASTIC

Part : **CORD GRIPP**

Date :

Rev : 1

Details :

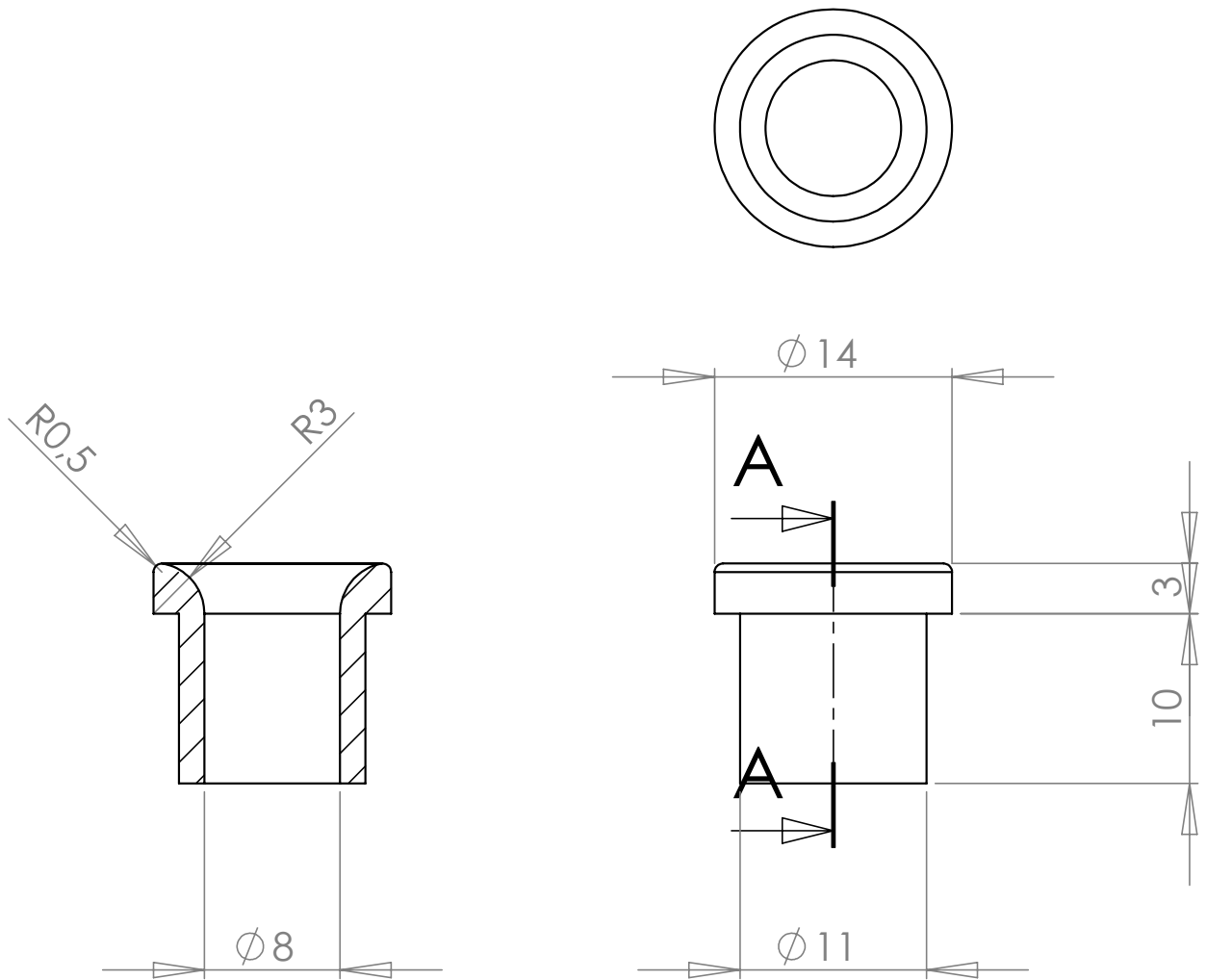

COUPE A-A

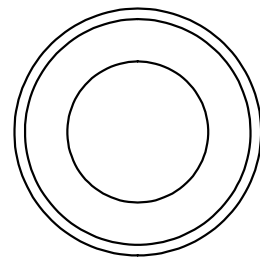

dcw.

Name : LAMP GRAS N330

Matériaux : PLASTIC

Part : CABLE EXIT

Date :

Rev : 1

Details :

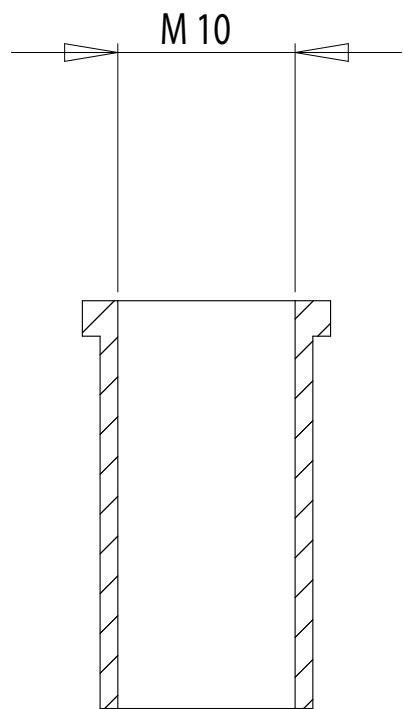
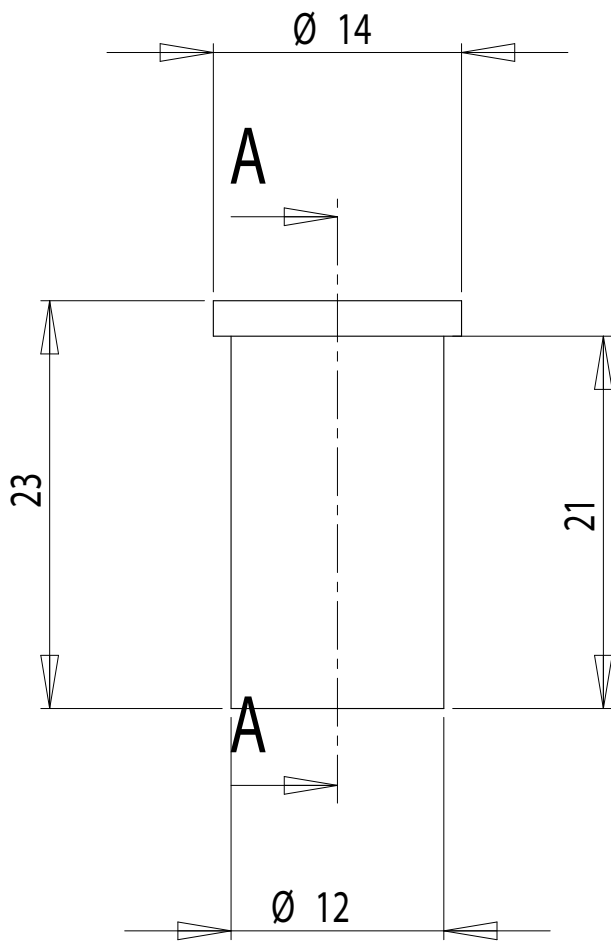

COUPE A-A

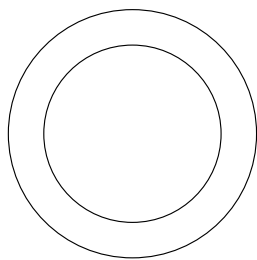

dcw.

Name : **LAMP GRAS**

Part : **FIXATION PIECE**

Date :

Rev : 1

Materials : PAINTED STEEL / CHROMED STEEL

Details :

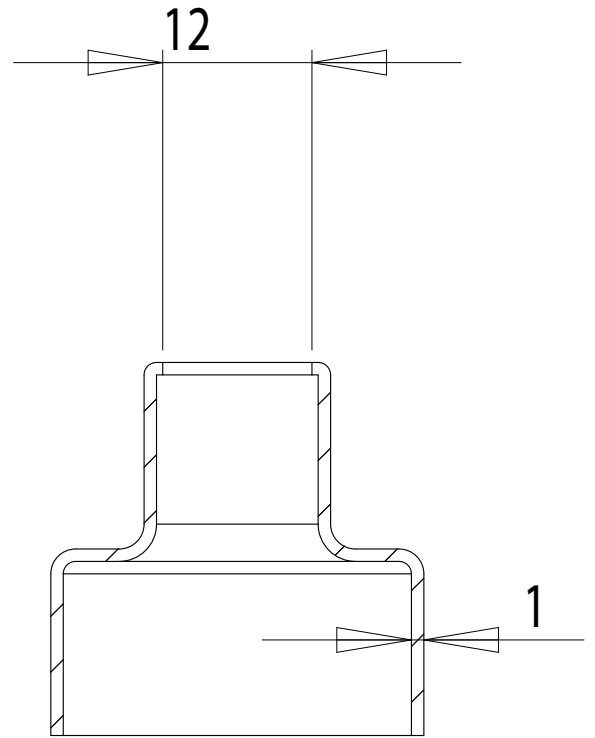
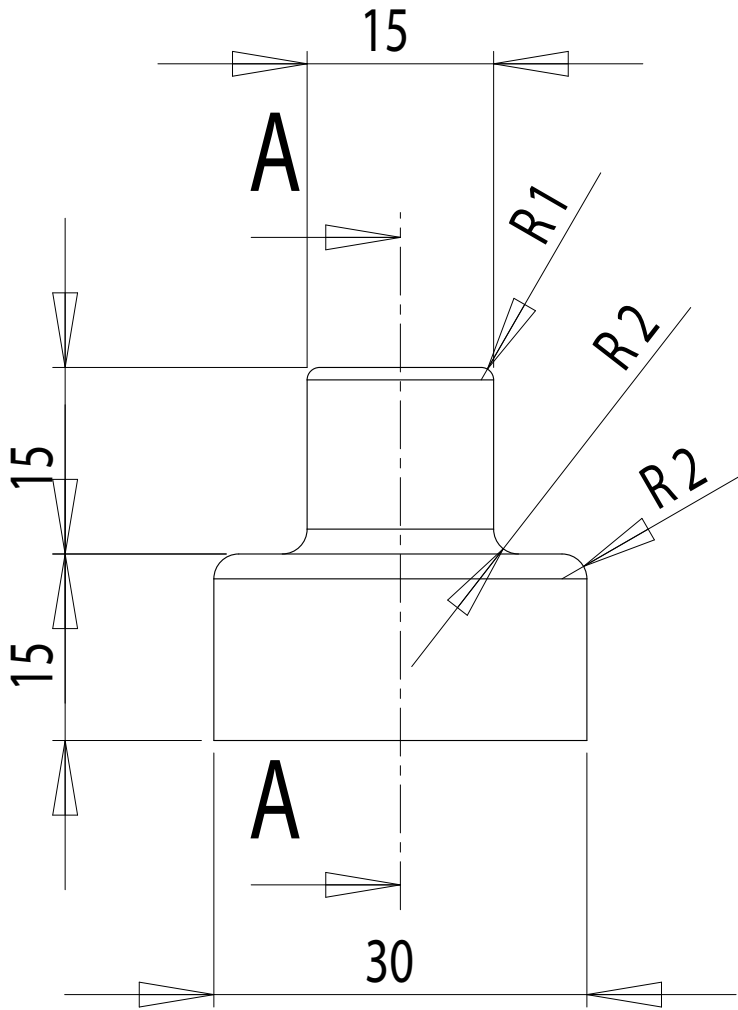

COUPE A-A

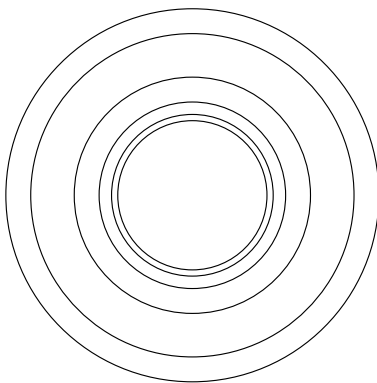

dcw.

Name : **LAMP GRAS**

Materials : PAINTED STEEL / CHROMED STEEL

Part : **COVERING PIECE**

Date :

Rev : 1

Details :

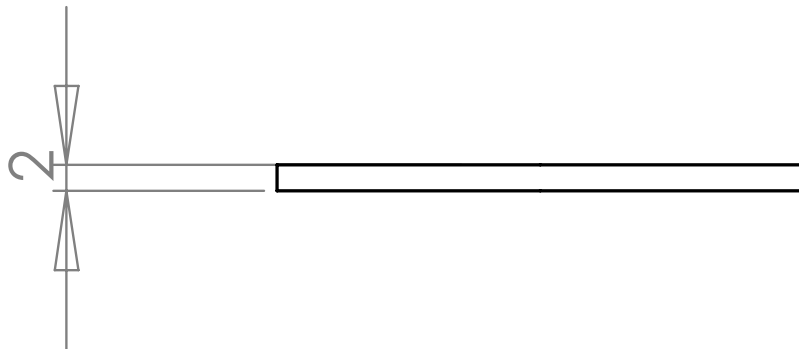
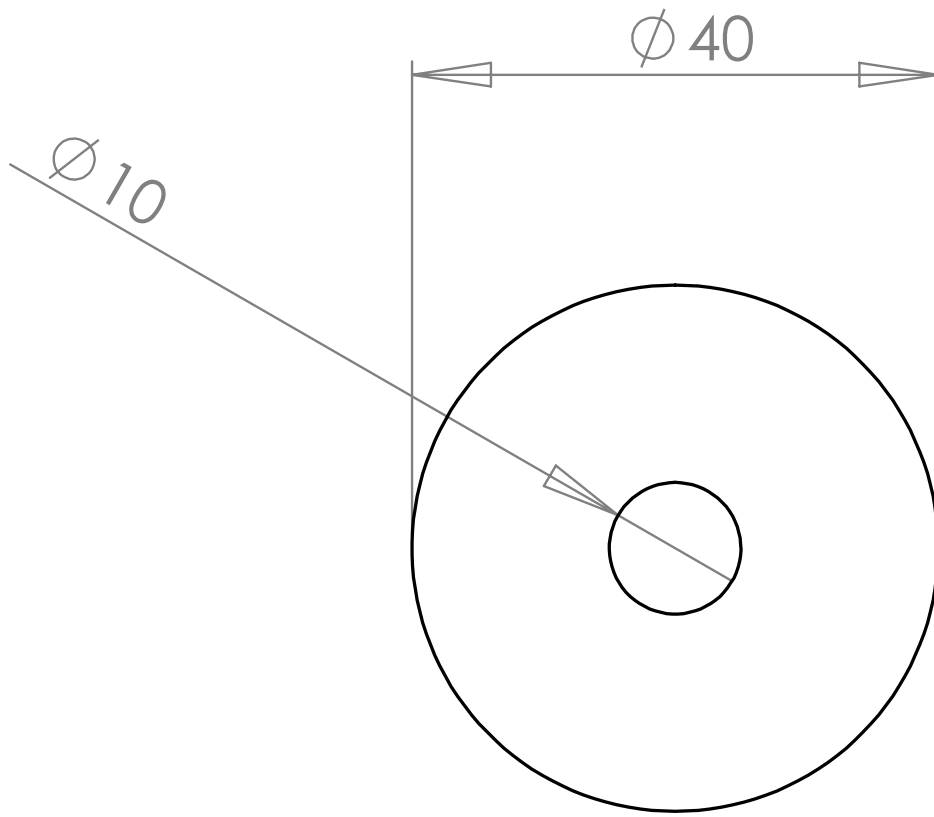

dcw.

Name : LAMP GRAS N330

Materials : PAINTED STEEL

Part : SHADE WASHER

Date :

Rev : 1

Details :

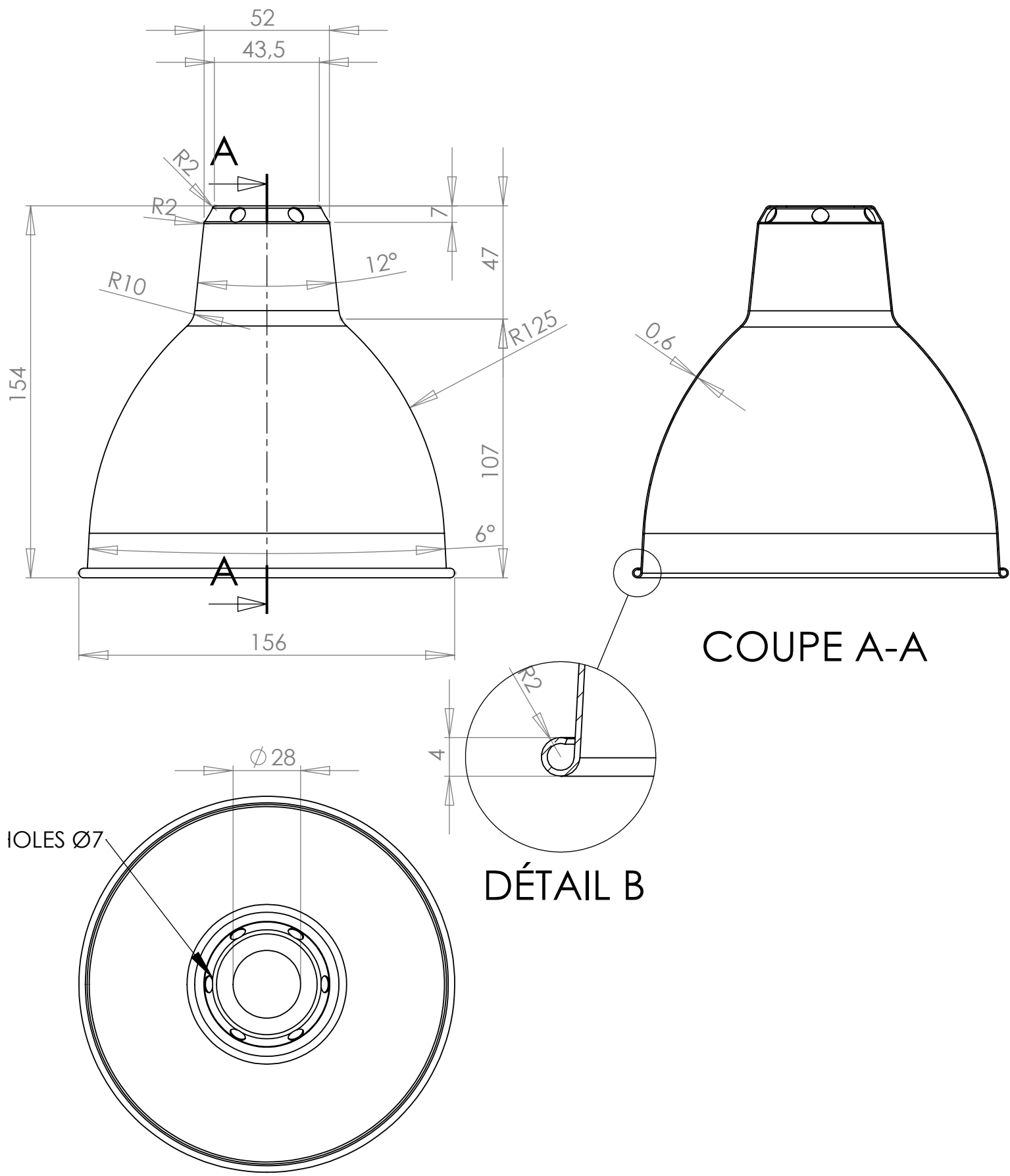

COUPE A-A

DÉTAIL B

dcw.

Name : LAMP GRAS		Materials : PAINTED STEEL/CHROMED STEEL
Part : ROUND SHADE LARGE		
Date :	Rev : 1	Details :